

Huawei eSight
V200R002C00

Hardware Installation Guide (N610E)

Issue: 01
Date: 2011-12-30

HUAWEI TECHNOLOGIES Co., Ltd.



Installation Process

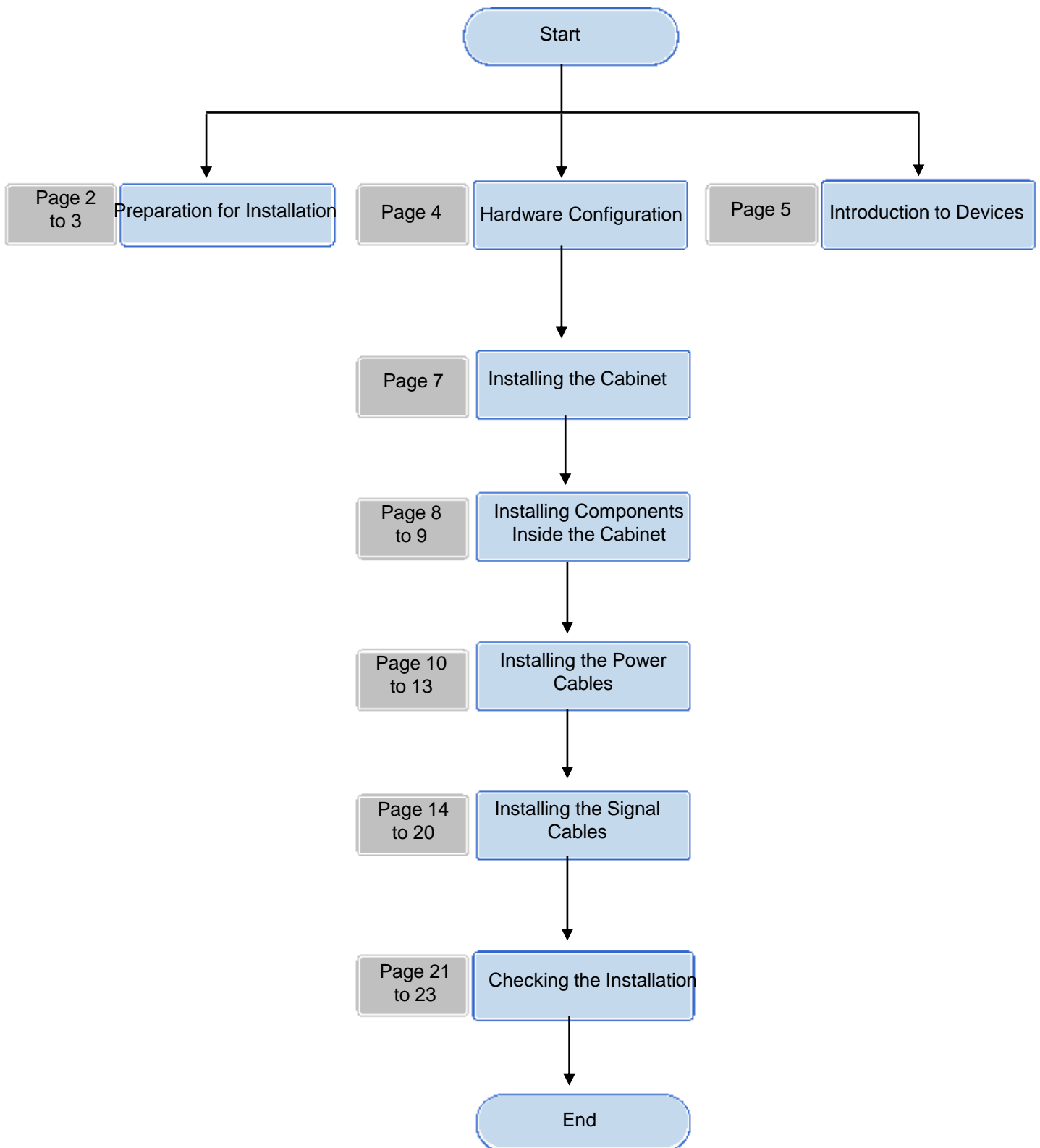

Preparation for Installation

1 Notice

This document describes how to install the hardware components, how to connect the power cables and signal cables, and how to check the connections when the IBM X3650M3 server act as the server of eSight.

The cabinet configuration, power cable connection, and signal cable connection that are detailed in this document are written according to the standard configuration. If the actual on-site installation requirements are inconsistent with this document, handle the requirements according to the actual situation. Unless otherwise specified, the slide rails installed in the cabinet are used for the corresponding devices. The models of the corresponding floating nuts and panel screws are M6.

2 Document Preparation

The following document must be prepared before the installation:

[N610E Cabinet Installation Guide \(V2.0\)](#)

This document is delivered with the cabinet.

3 Tools



Measuring Tape



Phillips Screwdriver



Flat-head Screwdriver



Torque Wrench



Socket Wrench



Hydraulic Pliers



COAX Crimping Tool



Cable Cutter



Wire Stripper



Diagonal Pliers



RJ45 Crimping Tool



Multimeter



Network Cable Tester



ESD Gloves

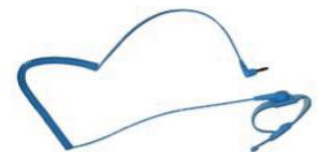

ESD Wrist Strap

46U		46U
45U	Power Distribution Box (3U)	45U
44U		44U
43U	Filler panel (1U)	43U
42U	Filler panel (1U)	42U
41U	LAN Switch - 2 (1U)	41U
40U	Cabling trough (1U)	40U
39U	LAN Switch - 1 (1U)	39U
38U	Cabling trough (1U)	38U
37U	Filler panel (1U)	37U
36U	Filler panel (1U)	36U
35U	Filler panel (1U)	35U
34U		34U
33U	Filler panel (2U)	33U
32U	X3650 M3 - 4 (2U)	32U
31U		31U
30U	Cabling trough (1U)	30U
29U		29U
28U	Filler panel (2U)	28U
27U	X3650 M3 - 3 (2U)	27U
26U		26U
25U	Cabling trough (1U)	25U
24U	Nonstandard filler panel (1U)	24U
23U	KVM (1U)	23U
22U	Nonstandard filler panel (1U)	22U
21U	Filler panel (1U)	21U
20U	Nonstandard filler panel (1U)	20U
19U	Filler panel (1U)	19U
18U	Nonstandard filler panel (1U)	18U
17U		17U
16U	Filler panel (2U)	16U
15U		15U
14U	Filler panel (3U)	14U
13U		13U
12U	Filler panel (1U)	12U
11U	Filler panel (2U)	11U
10U		10U
09U	X3650 M3 - 2 (2U)	09U
08U		08U
07U	Filler panel (2U)	07U
06U		06U
05U	Filler panel (2U)	05U
04U		04U
03U	X3650 M3 - 1 (2U)	03U
02U		02U
01U	Filler panel (1U)	01U

⚠ CAUTION

The cabinet configuration has passed the strict verification, and can meet the requirements for the power consumption and heat dissipation. Install the X3650 M3 server by strictly complying with the left installation flowchart.

Introduction to Devices

The eSight components include the server, KVM, and LAN Switch. The following table shows the specifications of each equipment. For details about the equipment parameters, see the associated manuals delivered with the equipment.

Component	Height (U)	Weight (kg)	Power Consumption (W)	Input Voltage (V)
PC server (IBM X3650 M3)	2	29.3	835	100 to 132/200 to 240
Switch	1	3	30	100 to 240
KVM	1	13	56	90 to 264

Taking Antistatic Measures

1 Wearing an Antistatic Wrist Strap

Scenario 1

Wearing an ESD-preventive wrist strap (plugged).



Scenario 2

Wearing an ESD-preventive wrist strap (with metallic clip).

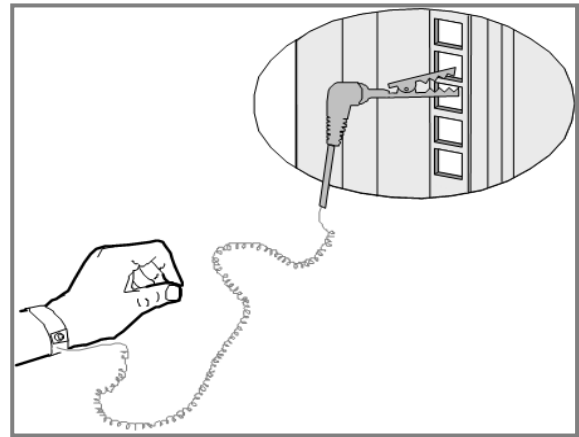

NOTE

After wearing the ESD-preventive wrist strap, insert the wrist strap into the ESD plug of the cabinet. You can clip the ESD-preventive wrist strap with metallic clip to the cabinet directly.

2 Wearing Antistatic Clothes



3 Wearing Antistatic Gloves



Installing the Cabinet

For cabinet installation, refer to the [N610E Cabinet Installation Guide \(V2.0\)](#)

N610E-22 Cabinet



Introduction to the N610E-22 cabinet:
N610E-22 cabinets are classified into single-door cabinets and double-door cabinets. The left figure shows the appearance of a double-door cabinet. The appearance of an actually delivered cabinet may be different.

The N610E-22 cabinet complies with the requirement of the dimensions of mechanical structures of the 482.6 mm (19 inch) series (IEC 60297-1 standard).

Cabinet Type	Available Height Inside the Cabinet	Dimensions (W × D × H)
N610E-22	46 U	600 mm x 1000 mm x 2200 mm
		24 inch x 39 inch x 87 inch

Installing the Components Inside the Cabinet

1 Flowchart of installing the components inside the cabinet

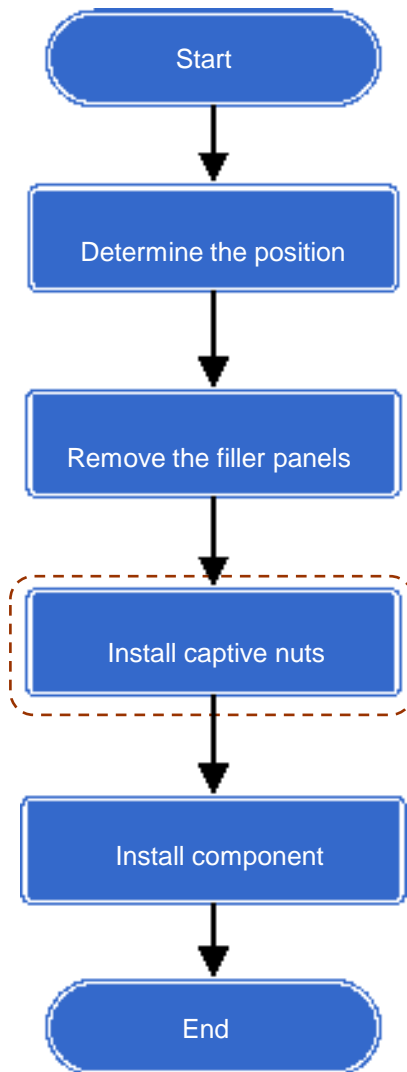

WARNING

Take care not to stab fingers with screwdriver.

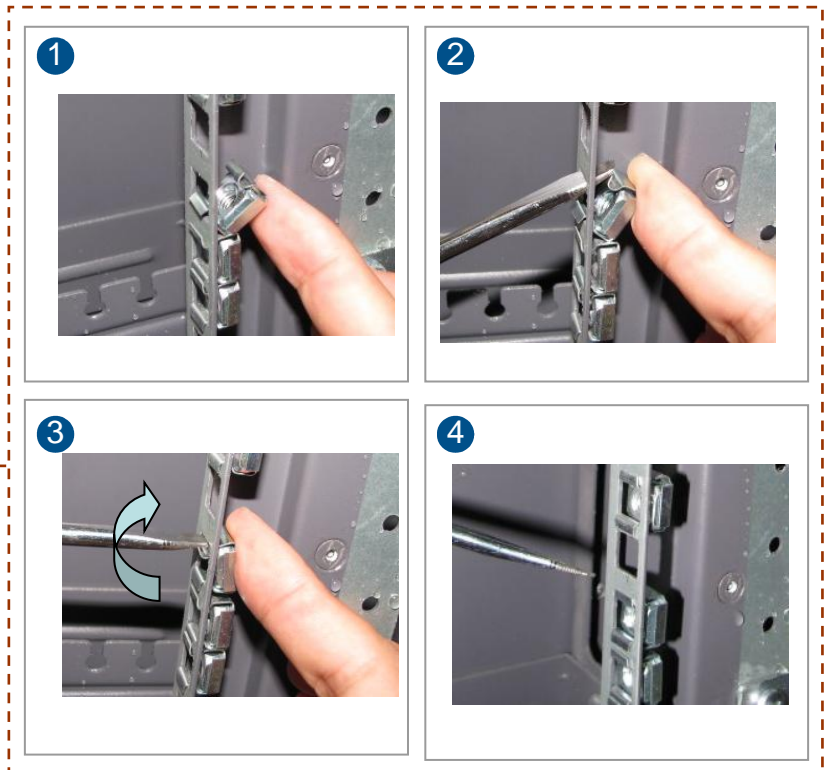

The procedure for installing the captive nut is as follows:

- 1 Insert the lower tab of the captive nut into the square hole and hold the captive nut in position.
- 2 Insert a flat-head screwdriver through the square hole and place the end of the screwdriver onto the upper tab of the captive nut.
- 3 Use the screwdriver as a lever, and gently but firmly bend the upper tab of the captive nut downwards when pushing it through the square hole.
- 4 Remove the flat-head screwdriver to allow the upper tab to spring into position and release your hand. The assembly is complete.

2 Installing the PC server (X3650M3)

CAUTION

The PC server is heavy, and two or three persons are required to carry the PC server.

- 1 Determine the position in the cabinet for installing the PC server.
- 2 Remove the handle bar of the front panel.
- 3 Fix the PC server by using screws.
- 4 Install the handle bar of the front panel.

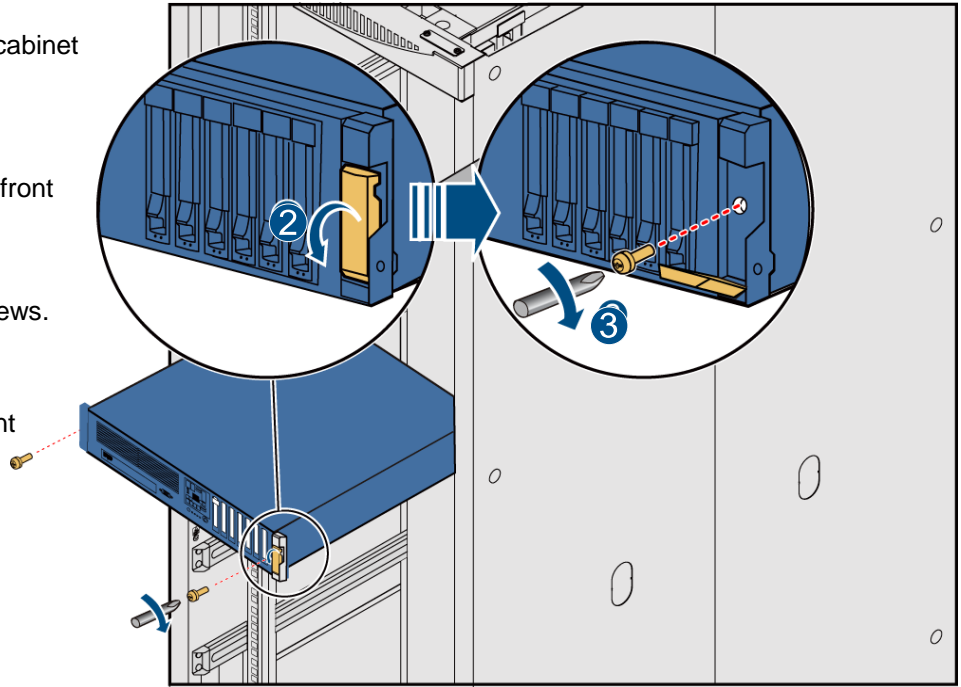

3 Installing the KVM

CAUTION

If the captive nuts for installing rack-mounting ears are blocked by cables on the mount angle, remove the cable tie and adjust the position of the cables. Then, bind the cables again after the KVM is installed.

- 1 Use the panel screws to fix the rear mounting point of the KVM to the square holes on both sides of the cabinet.

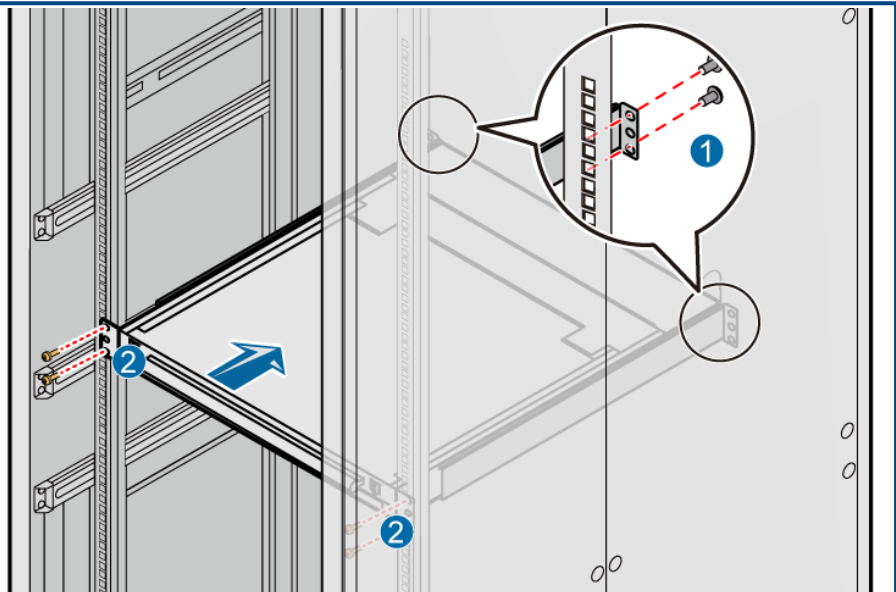

- 2 Use the panel screws to fix the front mounting point of the KVM to the square holes on both sides of the cabinet.

4 Guide to Installing the Power Cables (When X3650 M3 Is installed)

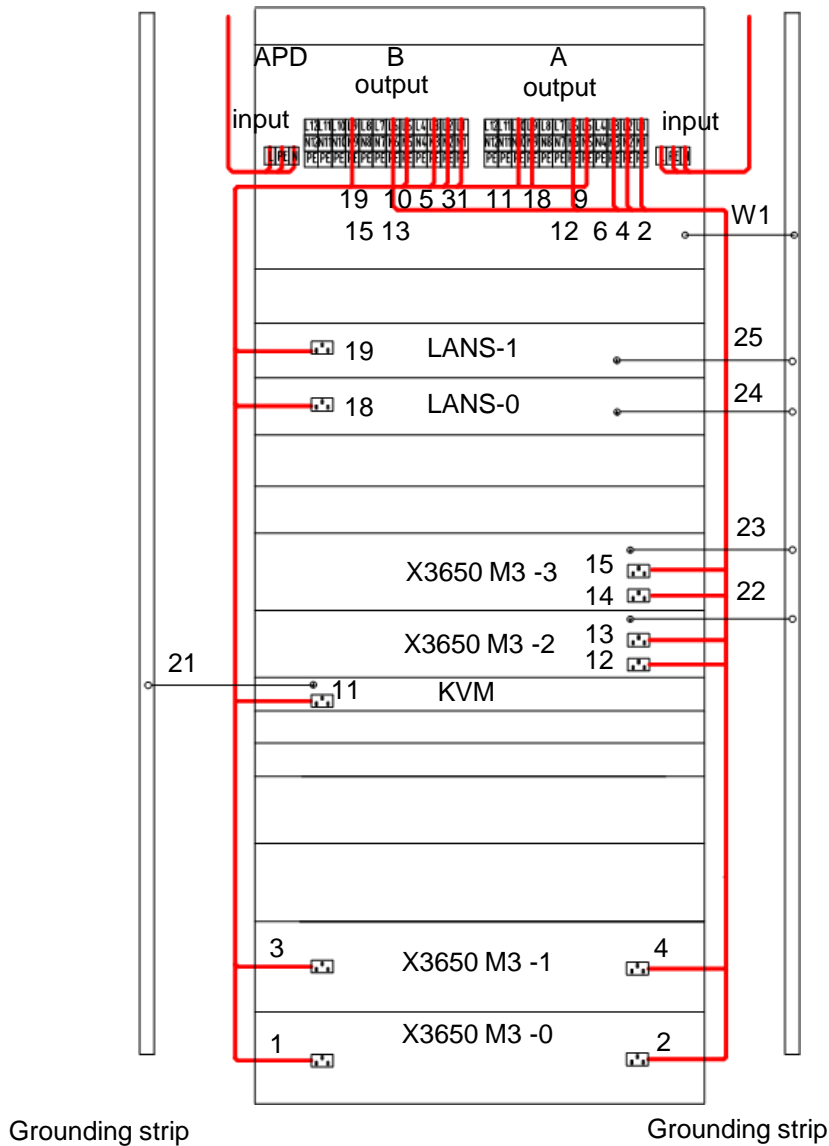

Cable No.	Description
1,2,3,4,12,13,14,15	Power cables of the X3650 M3 server
11	Power cables of the KVM
18,19	Power cables of the LAN Switch

- The Label No. refers to the number printed on the cable label.

- The Cable No. refers to each cable number in the diagram.

- The remaining cables that need not to be installed are bound in the applicable position of the cabinet and is delivered as the accessories.

5 Installing external power cables

a Install the power cables according to the upward cabling.

DANGER

Ensure that the switches of the power distribution box and power distribution cabinet are turned off before connecting the external power cables to the cabinet.

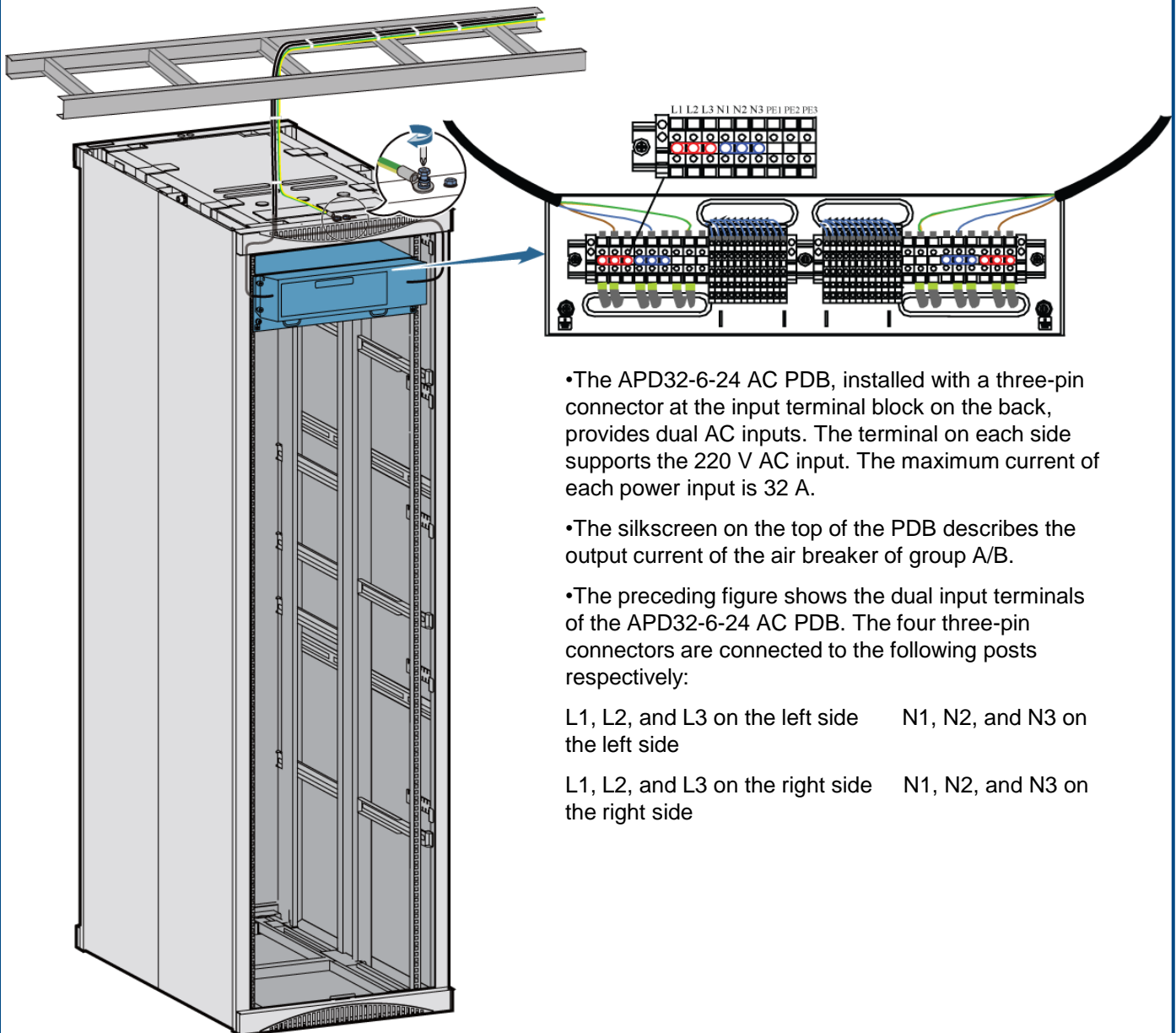

- The APD32-6-24 AC PDB, installed with a three-pin connector at the input terminal block on the back, provides dual AC inputs. The terminal on each side supports the 220 V AC input. The maximum current of each power input is 32 A.

- The silkscreen on the top of the PDB describes the output current of the air breaker of group A/B.

- The preceding figure shows the dual input terminals of the APD32-6-24 AC PDB. The four three-pin connectors are connected to the following posts respectively:

L1, L2, and L3 on the left side N1, N2, and N3 on the left side

L1, L2, and L3 on the right side N1, N2, and N3 on the right side

5 Installing external power cables

b Install the power cables according to the downward cabling.

DANGER

Ensure that the switches of the power distribution box and power distribution cabinet are turned off before connecting the external power cables to the cabinet.

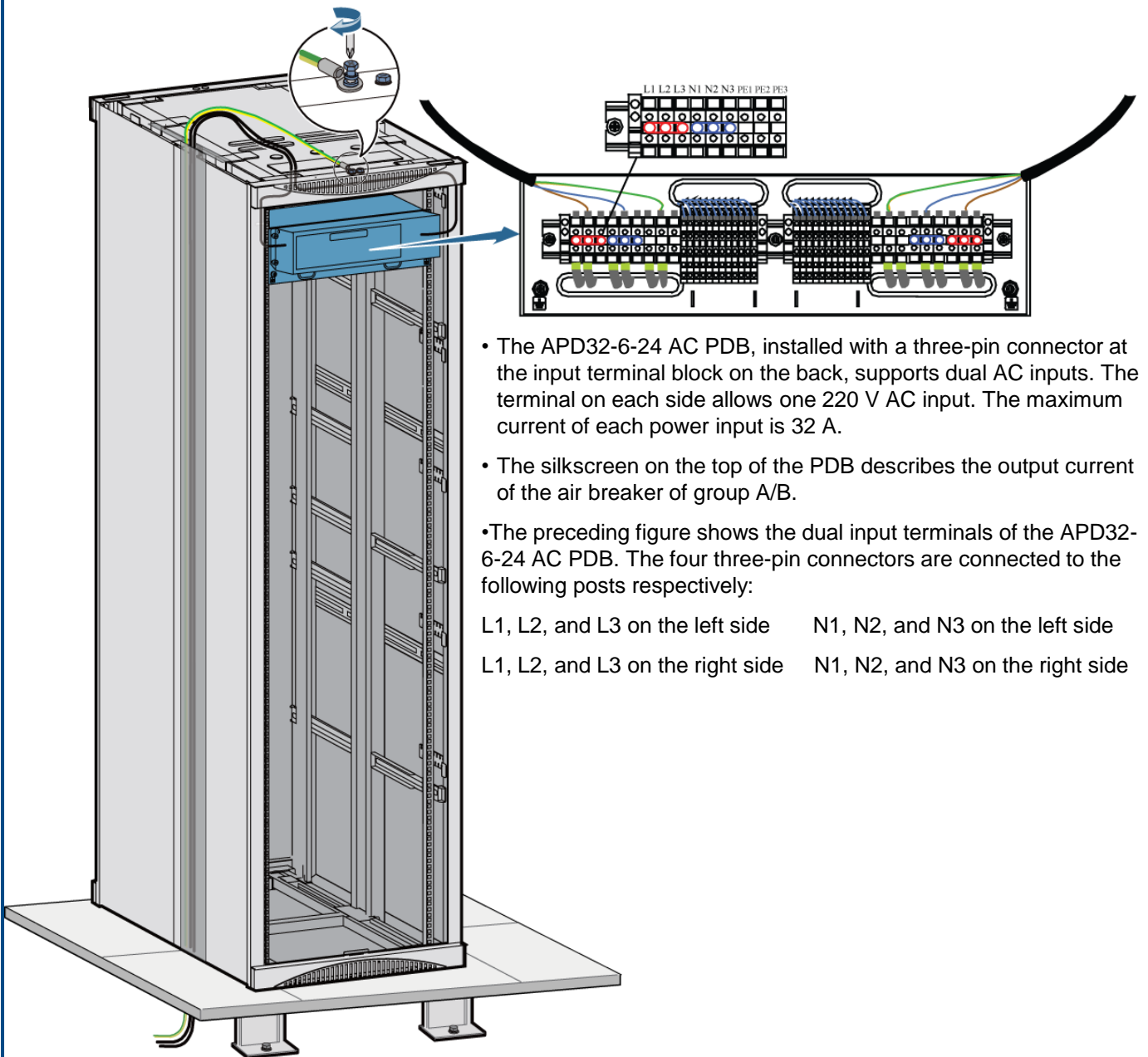

- The APD32-6-24 AC PDB, installed with a three-pin connector at the input terminal block on the back, supports dual AC inputs. The terminal on each side allows one 220 V AC input. The maximum current of each power input is 32 A.

- The silkscreen on the top of the PDB describes the output current of the air breaker of group A/B.

- The preceding figure shows the dual input terminals of the APD32-6-24 AC PDB. The four three-pin connectors are connected to the following posts respectively:

L1, L2, and L3 on the left side	N1, N2, and N3 on the left side
L1, L2, and L3 on the right side	N1, N2, and N3 on the right side

5 Installing external power cables

C Specifications of external cables

The following table lists the specifications of the cables connected to the AC power distribution cabinet.

Function	Electrical cable
Dielectric strength	300.0 V
Maximum current	36 A
Type	227IEC10 (BVV)
Color	Black jacket (cable core: blue, brown, yellow/green)
Cross-sectional area	6.00 mm ²
Wire gauge	Default
Remarks	3 cores

Installing Signal Cables

1 Description of signal cables

KVM (rear view)

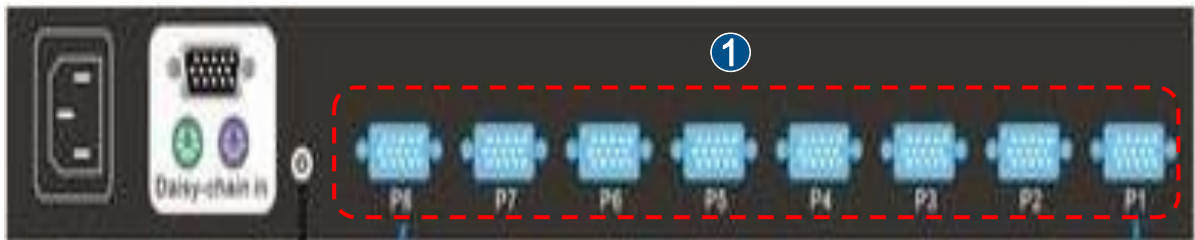

NOTE

The position of each interface on the preceding devices varies with actual devices. The pictures in this document are referential to describe the installation procedure of the device. If the pictures are different from the delivered devices, take the delivered devices as the standard. For details about the devices, see the associated manuals delivered with the devices.

Number	KVM
1	PS/2 interface

2 Description of signal cables

IBM X3650M3 (rear view)

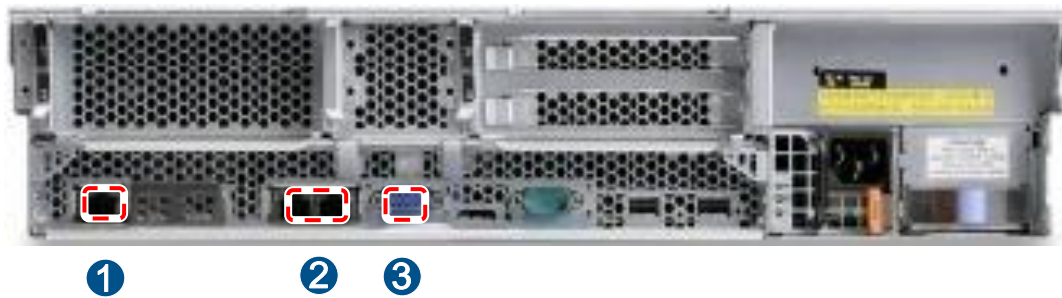

NOTE

The position of each interface on the preceding devices varies with actual devices. The pictures in this document are referential to describe the installation procedure of the device. If the pictures are different from the delivered devices, take the delivered devices as the standard. For details about the devices, see the associated manuals delivered with the devices.

Number	IBM X3650M3
1	IMM interface
2	Ethernet interface
3	VGA interface

3 Introduction to signal cables



Network cable



Serial cable (RJ-45 to DB-9)



Fiber



KVM controlling conversion cables

4 Introduction to cable labels

Connection relationships of the signal cables are marked after the commissioning of the device. Labels are attached at both ends of a cable and the ports of the server.



5 Cable connection of the X3650M3 server

NOTE

When connecting cables, comply with the following principle:
Connecting an Ethernet interface of the server and the switch by using a network cable HP

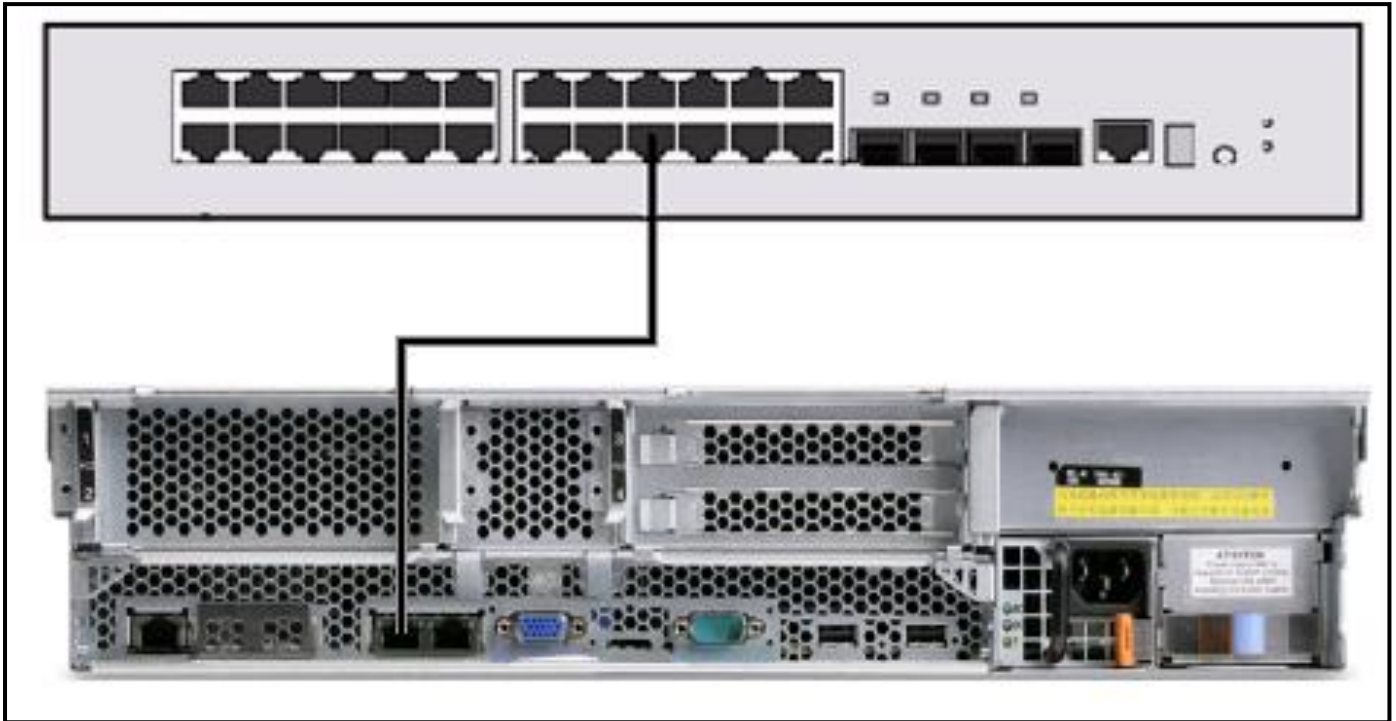

6 Cable connection of the KVM



NOTE

The principle for connecting the cables of the Keyboard, Video, and Mouse (KVM) is as follows:
Connecting the PS/S interface of the KVM and the mouse, keyboard, and VGA interface of the server by using KVM conversion power cables

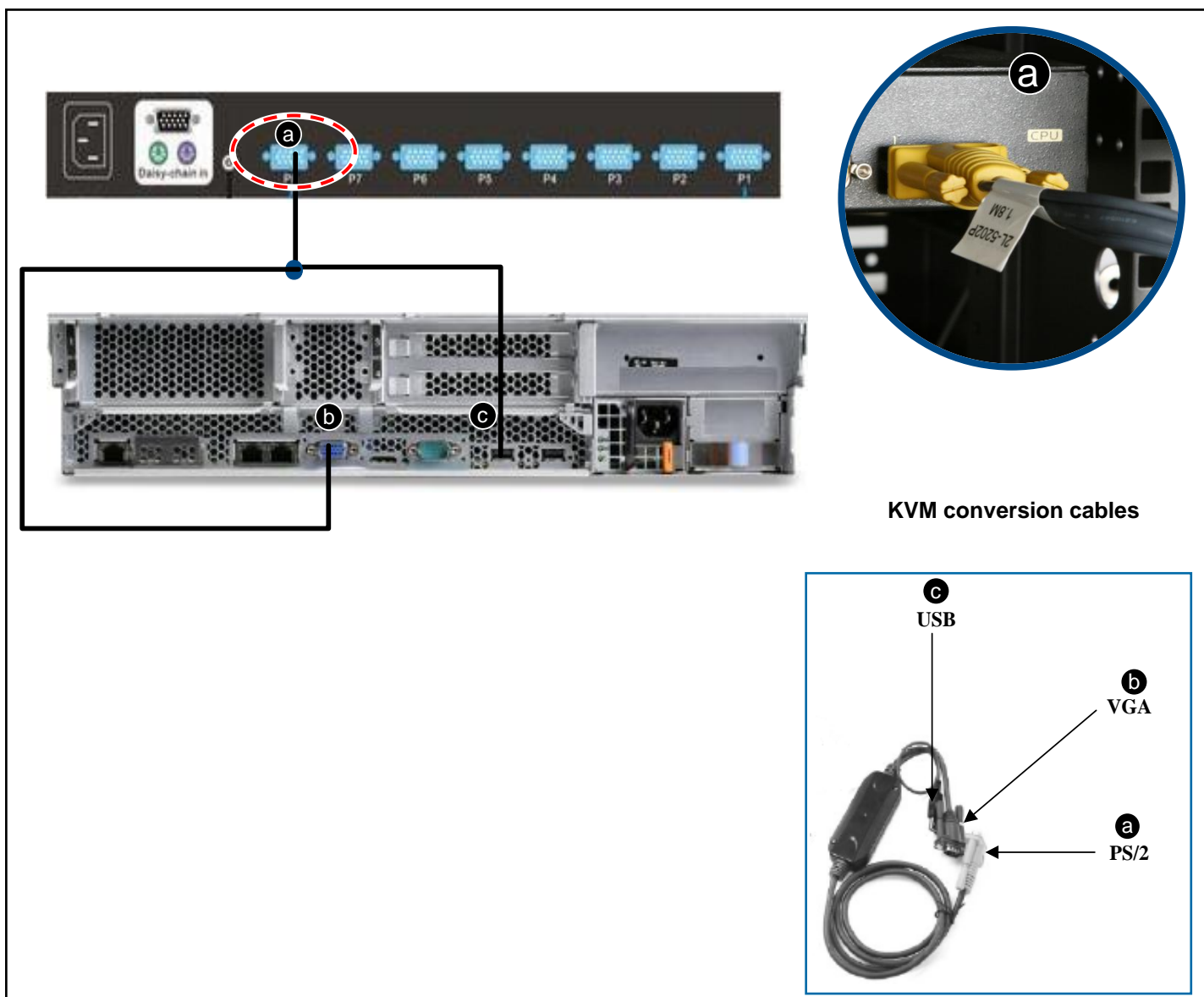

7 Laying network cables

a Lay network cables inside the cabinet.

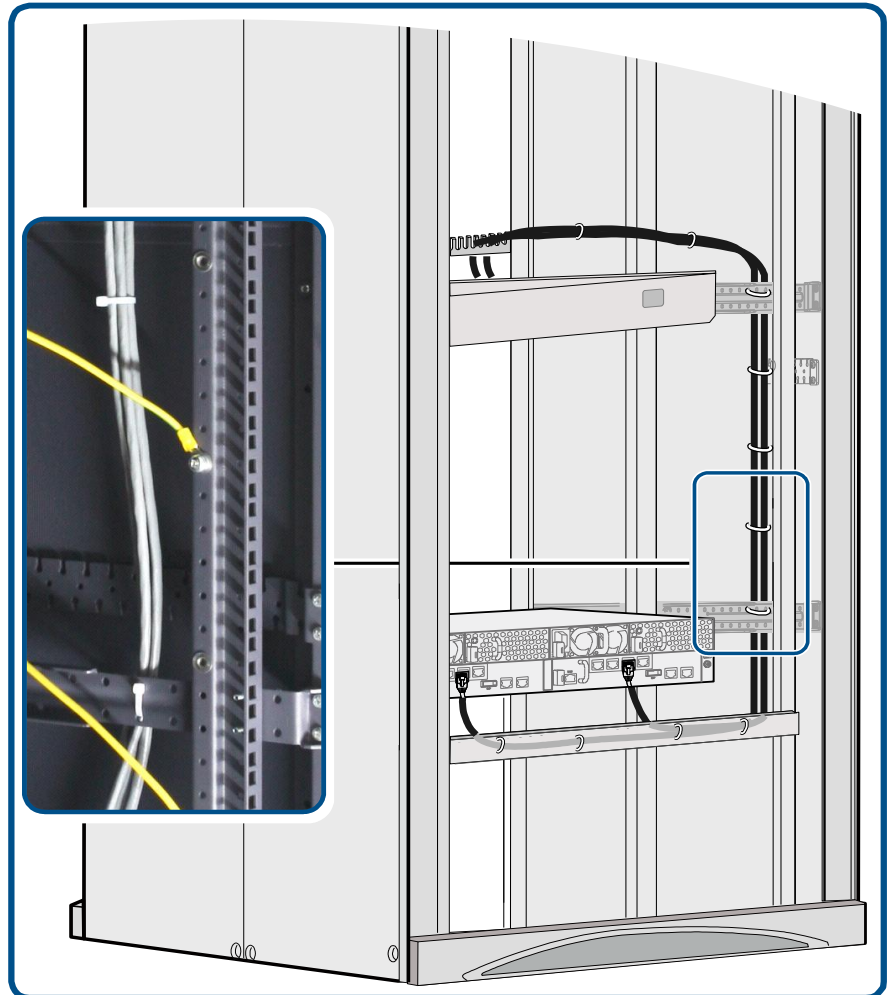

b Lay network cables underground between cabinets.

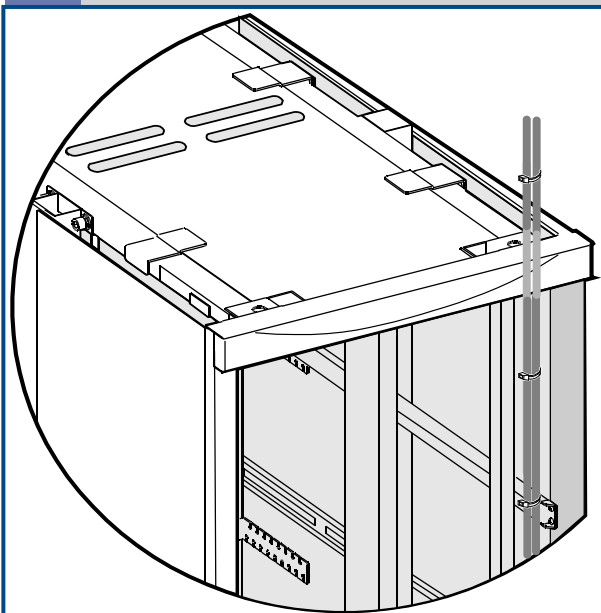

c Lay network cables overhead between cabinet.

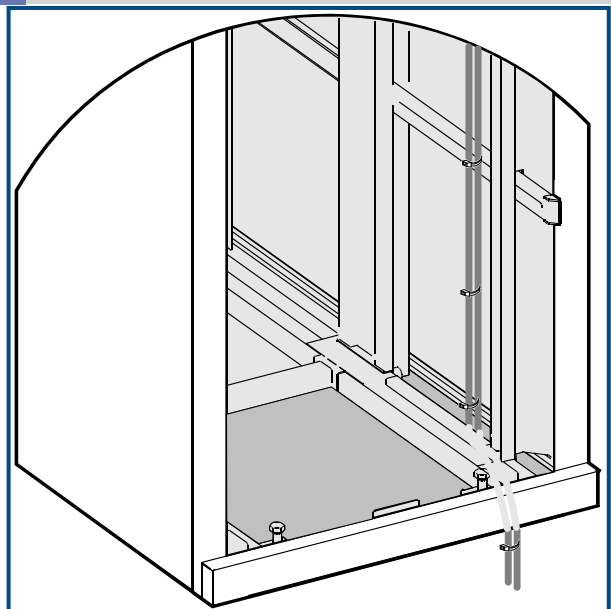

8 Laying optical fibers

a Lay optical fibers inside a cabinet.

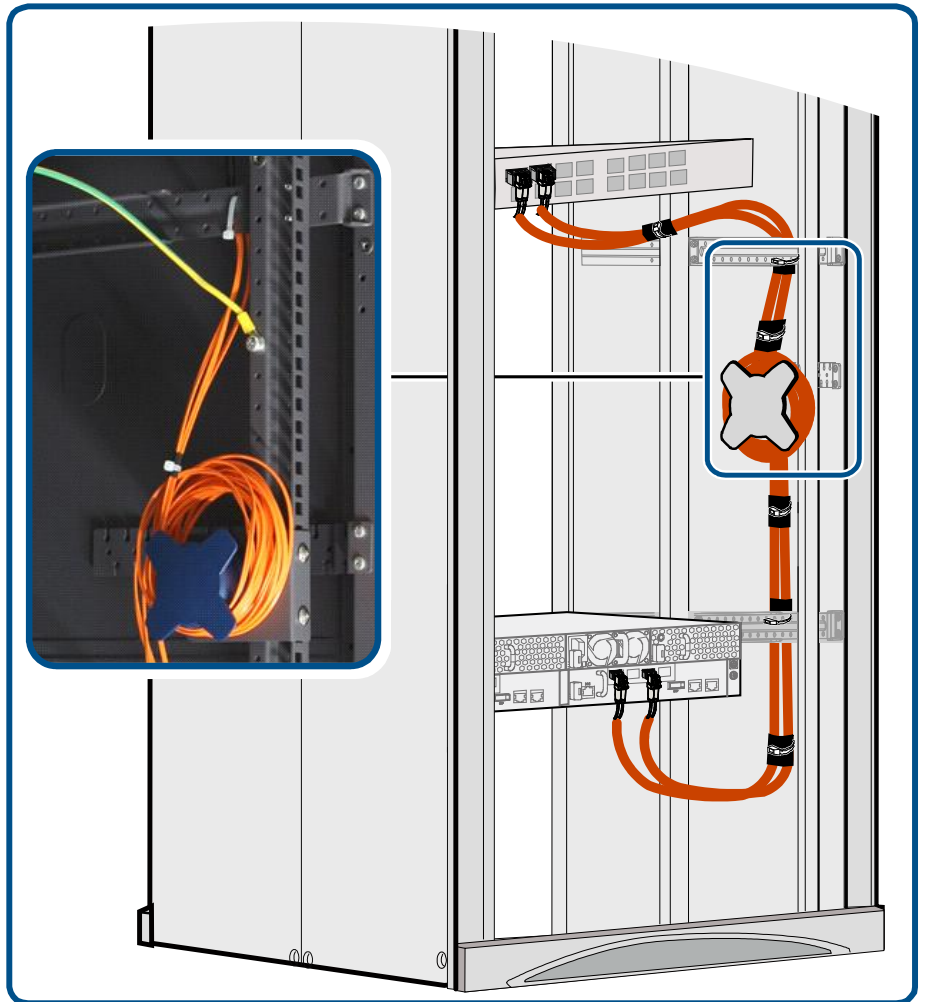

b

Lay optical fibers underground between cabinets.

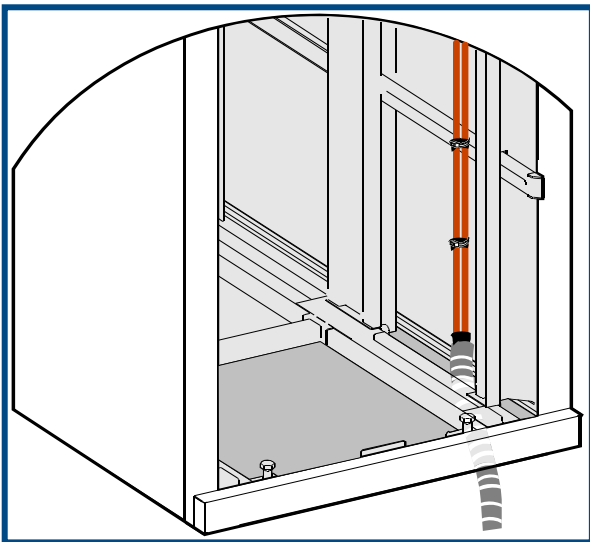

c

Lay optical fibers overhead between cabinets.

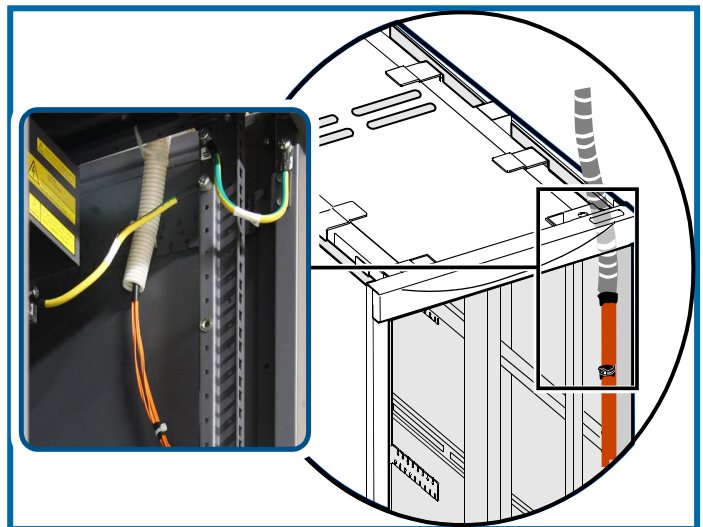

Checking the Installation

1 Checking the installation of the cabinet

No.	Item
1	The cabinet layout complies with the engineering design.
2	All supports are properly fixed to the floor. (This item is applicable to the installation of the ESD floor.)
3	The support assembly is installed correctly. (This item is applicable to the installation of the ESD floor.)
4	Each cabinet is well insulated from the support or the floor.
5	The plastic covers on the top and bottom of the cabinet are installed.
6	Accessories such as the side, front, and back doors are installed.
7	Product labels and labels that indicate cabinet rows and columns are correctly attached.
8	The ESD wrist strap is inserted into the ESD installation hole of the cabinet.
9	All screws are fastened. The flat washers and spring washers are mounted. The spring washers are placed between the flat washers and the screws.
10	The cabinets are stable and orderly.
11	The vertical deviation of the cabinet is less than 3 mm.
12	All cabinet side doors facing the aisle are aligned properly, with the maximum deviation of 5 mm.
13	The front and back doors of the cabinet open and close easily.
14	The surfaces of the cabinets are clean without any fingerprint or smudge. The paint on the surfaces of the cabinets is intact.
15	All dummy panels are installed.
16	Ensure that no unnecessary materials such as screws or clips are kept in the cabinet.

2 Checking the installation of power cables

No.	Item
1	All the power cables and PGND cables are copper-core cables.
2	There are no solder joints or connectors in the power cables and the PGND cables.
3	The extra length of power cables or PGND cables are truncated and are not coiled.
4	There is no breaking equipment such as switches and fuses in the electrical connection of the grounding system.
5	The grounding bars and PGND bars are connected to the same grounding conductor.
6	The earth resistance is smaller than 10 ohms.
7	The OT terminals at both ends of the power cables or PGND cables are soldered or crimped securely.
8	The bare wires and OT terminals at the wiring terminals are tightly wrapped up with the insulating tape or heat-shrinkable tubes.
9	All screws are fastened. The flat washers and spring washers are mounted. The spring washers are placed between the flat washers and the screws.
10	The power cables and PGND cables connecting the PDB with the functional modules and the PGND cables connecting the modules with the grounding bar are all correctly installed and in good contact.
11	The front and back doors are connected to the grounding bolts on the lower enclosure of the cabinet using 6 mm greenish yellow cables. Two such cables are used for each door.
12	The power cables and PGND cables are bound separately from other cables.
13	Labels are attached at both ends of the power cables and the PGND cables.
14	The plastic cover plate on the top of the terminals of the PDB is installed correctly.

3 Checking the installation of signal cables

No.	Item
1	There are no solder joints or connectors in the signal cables. The signal cables are not scratched or broken.
2	The connectors of the signal cables are tight and secure.
3	Proper length of the cable is reserved at the connectors.
4	Proper length is reserved for the signal cables at turning points. The turning radius meets the requirement.
5	The optical cables must be sheathed using corrugated pipes at outsides of cabinets. Both ends of the pipes must be fastened. The edges are smooth or be processed for cutting prevention.
6	No other cables are laid on the optical cables.
7	The extra optical cables are coiled on the fiber management tray at the rear side of the cabinet.
8	The signal cables connected to the left part of the subrack are led out of the subrack from the left. Similarly, the signal cables connected to the right part of the subrack are led out of the subrack from the right.
9	The signal cables are bound separately from the power cables.
10	The extra length of the cable ties must be cut and the cut surface must be smooth.
11	The signal cables are bound and arranged neatly and closely. The cable ties are spaced evenly. The tips of the cable ties point to the same direction.
12	The cables whose connectors are far away from the cable entrance are arranged at the external side of the cable bundle, while those near the entrance are arranged at the internal side of the cable bundle. The trunk cables are laid out smoothly without any tangling.

Changes in Documentation

01 (2011-12-30)

Initial release.

HUAWEI TECHNOLOGIES CO., LTD.

Huawei Industrial Base Bantian Longgang

Shenzhen 518129

People's Republic of China

www.huawei.com