

S1700 Unmanaged Series Ethernet Switches V100R007C00

Product Description

Issue **04**
Date **2012-10-25**

Copyright © Huawei Technologies Co., Ltd. 2012. All rights reserved.

No part of this document may be reproduced or transmitted in any form or by any means without prior written consent of Huawei Technologies Co., Ltd.

Trademarks and Permissions



and other Huawei trademarks are trademarks of Huawei Technologies Co., Ltd.

All other trademarks and trade names mentioned in this document are the property of their respective holders.

Notice

The purchased products, services and features are stipulated by the contract made between Huawei and the customer. All or part of the products, services and features described in this document may not be within the purchase scope or the usage scope. Unless otherwise specified in the contract, all statements, information, and recommendations in this document are provided "AS IS" without warranties, guarantees or representations of any kind, either express or implied.

The information in this document is subject to change without notice. Every effort has been made in the preparation of this document to ensure accuracy of the contents, but all statements, information, and recommendations in this document do not constitute a warranty of any kind, express or implied.

Huawei Technologies Co., Ltd.

Address: Huawei Industrial Base
Bantian, Longgang
Shenzhen 518129
People's Republic of China

Website: <http://enterprise.huawei.com>

About This Document

Intended Audience

This document describes the product position, product characteristics, product architecture, link features, service features, networking and applications, operation, maintenance and system technical specifications of S1700.





This document provides guides to get the information about how to construct a network.

This document is intended for:

- Policy planning engineers
- Installation and commissioning engineers
- NM configuration engineers
- Technical support engineers
- FAE
- Network monitoring engineers
- System maintain engineers

Symbol Conventions

The symbols that may be found in this document are defined as follows.

Symbol	Description
 DANGER	Indicates a hazard with a high level of risk, which if not avoided, will result in death or serious injury.
 WARNING	Indicates a hazard with a medium or low level of risk, which if not avoided, could result in minor or moderate injury.
 CAUTION	Indicates a potentially hazardous situation, which if not avoided, could result in equipment damage, data loss, performance degradation, or unexpected results.
 TIP	Indicates a tip that may help you solve a problem or save time.
 NOTE	Provides additional information to emphasize or supplement important points of the main text.

Change History

Changes between document issues are cumulative. Therefore, the latest document issue contains all changes made in previous issues.

Issue 04 (2012-10-25)

Compare to Issue 03 (2012-05-24) :
Optimize some pictures in version 03.

Issue 03 (2012-05-24)

Compare to Issue 02 (2012-04-26) :
Revise Contact Information.

Issue 02 (2012-04-26)

Compare to Issue 01 (2012-03-05) :
Revise:
2.3.1 Power Supply.

Issue 01(2012-03-05)

Compare to Issue 00 (2011-10-27) :
Add S1700-8G-AC.

Issue 00 (2011-10-27)

Initial release.

Contents

About This Document	ii
1 Product Positioning and Features	1
1.1 Product Positioning	1
1.2 Product Characteristics.....	1
1.2.1 Flexible Networking Capability.....	2
1.2.2 Energy-Saving Design	2
1.2.3 Advanced Lightning Protection Technologies.....	2
2 Product Architecture	3
2.1 Overview.....	3
2.2 Device Structure.....	3
2.3 Hardware Modules	6
2.3.1 Power Supply	7
3 Networking and Applications	8
3.1 Access on an Enterprise Network or a Campus Network.....	8
3.2 Desktop Access	9
4 System Technical Specifications	10
4.1 Physical Specifications.....	10
4.2 Optical Module Attributes	11
4.3 System Performance.....	12

1 Product Positioning and Features

About This Chapter

1.1 Product Positioning

1.2 Product Characteristics

1.1 Product Positioning



CAUTION

S1700-24-AC and S1700-52R-2T2P-AC are class A products. The switches that are operating may cause radio interference. Customers need to take prevention measures.

The S1700 Unmanaged Series Ethernet Switches (hereinafter referred to as the S1700) provide the access and data transport functions. They are developed by Huawei to meet the requirements for reliable access and high-quality transmission of multiple services on the enterprise network.

Positioned for the access layer of the enterprise network, the S1700 provides large capacity, high port density, and cost-effective packet forwarding capabilities. In addition, the S1700 provides multi-service access capabilities, and excellent extensibility.

The S1700 Unmanaged Series Ethernet Switches include S1700-8-AC, S1700-8G-AC, S1700-24-AC and S1700-52R-2T2P-AC.

1.2 Product Characteristics

1.2.1 Flexible Networking Capability

1.2.2 Energy-Saving Design

1.2.3 Advanced Lightning Protection Technologies

1.2.1 Flexible Networking Capability

S1700-8-AC/S1700-24-AC provides 10/100BASE-T Ethernet electrical interfaces.

S1700-8G-AC provides 10/100/1000BASE-T Ethernet electrical interfaces.

S1700-52R-2T2P-AC 48 provides 10/100BASE-T Ethernet electrical interfaces, 2 10/100/1000BASE-T Ethernet electrical interfaces and 2 1000BASE-X Ethernet optical interfaces.

S1700-52R-2T2P-AC provides swappable Small Form-Factor Pluggable (SFP) optical modules for optical fiber connections. The length of optical fibers can be selected according to the transmission distance.

1.2.2 Energy-Saving Design

The S1700 adopts the following measures to save energy:

- Adopts natural heat dissipation so that power consumed by fans is saved.
- The chip switches to the power saving mode when no connected device is detected on a service interface, that is, the interface is idle.
- It uses highly-integrated and energy-saving chips produced through advanced processing techniques. With the help of the intelligent device management system, the chips not only improve system performance but also greatly reduce power consumption of the entire system.

Natural heat dissipation has the following advantages:

- The product reliability is high.
- There is no noise pollution.
- You do not need to maintain the fans, which saves the maintenance cost.
- The system does not have additional power consumption generated by fans, which improves the power efficiency.
- Boards are prevented from being eroded.

1.2.3 Advanced Lightning Protection Technologies

The S1700 adopts the Huawei patented lightning protection technologies to protect the equipment. The lightning protection technologies reduce the probability of damages caused by lightning, thus greatly improving the device reliability.

2 Product Architecture

About This Chapter

- 2.1 Overview
- 2.2 Device Structure
- 2.3 Hardware Modules

2.1 Overview

S1700-8-AC/S1700-8G-AC adopts an integrated hardware platform. Its hardware system consists of the chassis, and main board.

S1700-24-AC/S1700-52R-2T2P-AC adopts an integrated hardware platform. Its hardware system consists of the chassis, power supply and main board. The width of S1700-24-AC/S1700-52R-2T2P-AC complies with industry standards, and can be installed in an IEC297 cabinet or an ETSI cabinet.

2.2 Device Structure

This section describes the structure of the S1700.

NOTE

The S1700-8-AC/S1700-8G-AC is a desktop device.

- The dimensions of the device are 160.0 mm x 134.0 mm x 32.77 mm (width x depth x height).
S1700-24-AC/S1700-52R-2T2P-AC is 1 U (1 U = 44.45 mm) high.
- The dimensions of S1700-24-AC is 320.0 mm x 208.0 mm x 43.8 mm (width x depth x height).
- The dimensions of S1700-52R-2T2P-AC is 442.0 mm x 220.0 mm x 43.8 mm (width x depth x height).

S1700 Appearances

Table 2-1 shows the front views of S1700.

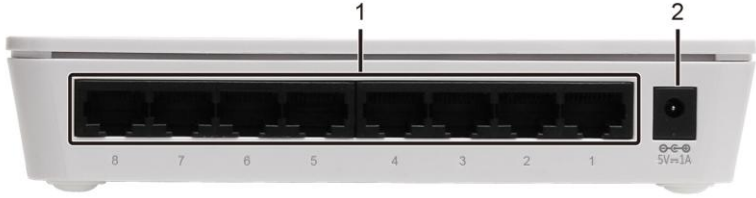



Table 2-1 S1700 front views

Model	Image
S1700-8-AC	
S1700-8G-AC	
S1700-24-AC	
S1700-52R-2T 2P-AC	

1. Power LEDs	2. Ethernet LEDs	3. 24 10/100BASE-T Ethernet interfaces	4. 48 10/100BASE-T Ethernet interfaces
5. 2 10/100/1000BASE-T Ethernet optical interfaces	6. 2 1000BASE-X Ethernet optical interfaces	7. GE1 – GE4 Ethernet LEDs	

Table 2-2 shows the rear views of S1700.

Table 2-2 S1700 rear views

Model	Image
S1700-8-AC	
S1700-8G-AC	
S1700-24-AC	
S1700-52R-2T 2P-AC	

1. 8 10/100BASE-T Ethernet interfaces	2. 5V 1A DC jack	3. Ground screw	4. AC jack
5. 8 10/100/1000 BASE-T Ethernet interfaces	6. 12V 0.5A DC jack		

2.3 Hardware Modules

The logical structure of hardware modules of the S1700 are shown as below.

Figure 2-1 Logical structure of hardware modules of the S1700-8-AC

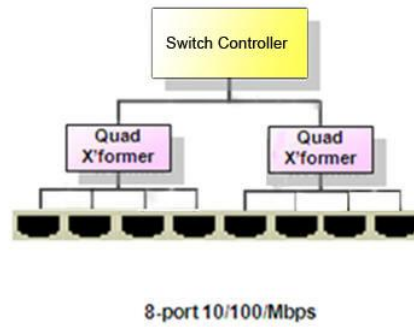

Figure 2-2 Logical structure of hardware module of the S1700-8G-AC

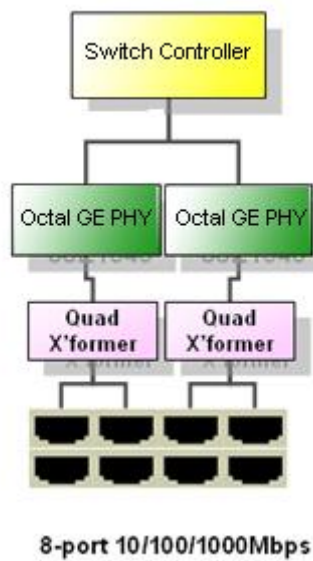

Figure 2-3 Logical structure of hardware modules of the S1700-24-AC

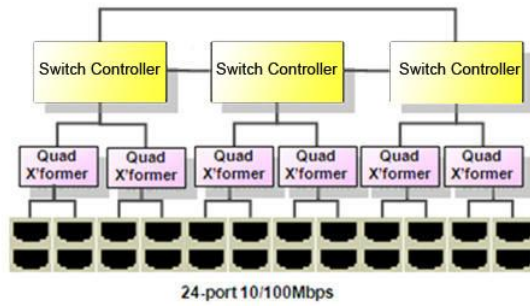
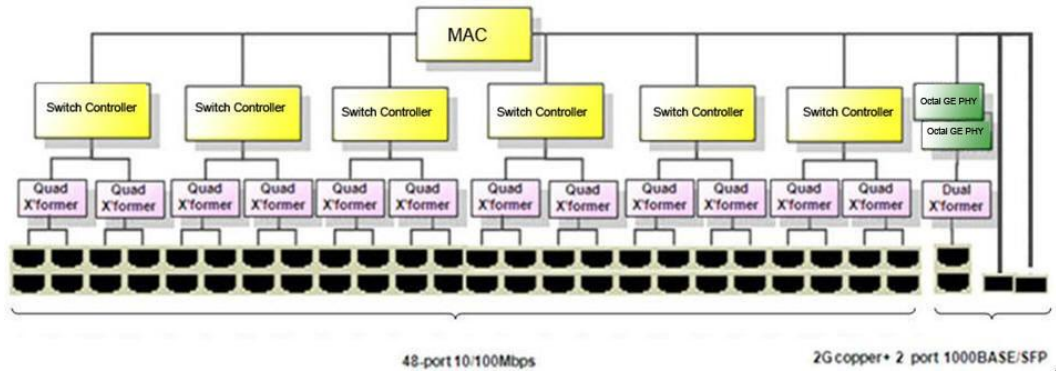

Figure 2-4 Logical structure of hardware modules of the S1700-52R-2T2P-AC



2.3.1 Power Supply

S1700-8-AC/S1700-8G-AC only supports the DC power supply, hence utilizing the AC-DC adapter to supply power to the whole system.

S1700-24-AC/S1700-52R-2T2P-AC only supports the AC power supply.

Table 2-3 Power supply

Device Name	AC	DC
S1700-8-AC	N	Y
S1700-8G-AC	N	Y
S1700-24-AC	Y	N
S1700-52R-2T2P-AC	Y	N

3 Networking and Applications

About This Chapter

3.1 Access on an Enterprise Network or a Campus Network

3.2 Desktop Access

Figure 3-1 Campus topology

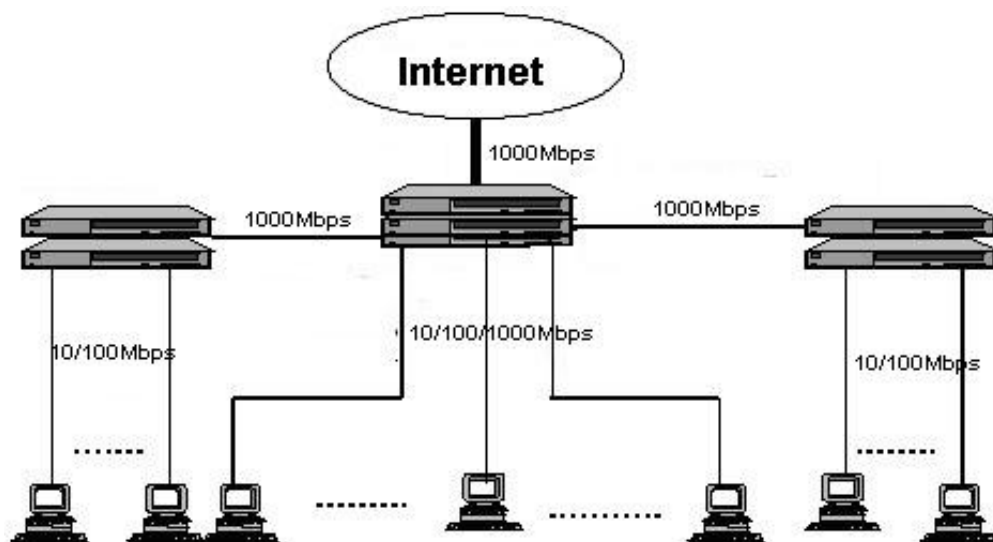

3.1 Access on an Enterprise Network or a Campus Network

In an enterprise network and a campus network, the S1700 access to end users through the Fast/Gigabit copper port, uplink through Gigabit optical port or gigabit copper port to aggregation layer switch, then tied through the Gigabit or 10Gigabit uplink to the backbone networks, in order to constitute the 10Gigabit backbone, 100M to desktop total solution to meet customers high-bandwidth, multi-service requirements.

3.2 Desktop Access

With the compact design, S1700 provides a variety of desktop access.

4 System Technical Specifications

About This Chapter

- 4.1 Physical Specifications
- 4.2 Optical Module Attributes
- 4.3 System Performance

4.1 Physical Specifications

Table 4-1 Physical specifications

Item		Description
Dimensions (width x depth x height)		<ul style="list-style-type: none"> • S1700-8-AC: 160.0mm*134.0mm*32.77mm • S1700-8G-AC: 160.0mm*134.0mm*32.77mm • S1700-24-AC: 320.0mm*208.0mm*43.80mm • S1700-52R-2T2P-AC: 442.0mm*220.0mm*43.80mm
Maximum power (full configuration)		<ul style="list-style-type: none"> • S1700-8-AC: 4.3W • S1700-8G-AC: 4.5W • S1700-24-AC: 10.9W • S1700-52R-2T2P-AC: 22.6W
Weight		<ul style="list-style-type: none"> • S1700-8-AC: 296g • S1700-8G-AC: 306g • S1700-24-AC: 1670g • S1700-52R-2T2P-AC: 2543g
AC input voltage	Rated voltage	100V AC to 240V AC
	Maximum voltage	90V AC to 264V AC
Temperature	operating temperature	-0 °C to 45 °C

Item		Description
	Storage temperature	-20 °C to 70 °C
Relative humidity		10% RH to 95% RH
Altitude		0 m to 2000 m

4.2 Optical Module Attributes

Table 4-2 Attributes of the ESFP (GE) optical module

Attribute	Specification		
Transmission distance	FTLF8519P2BNL-HW	PT7320-51-1W-KHW MXPDP-243S RTXM191-400	RTXM191-450 PT7420-51-EW
Distance	0.5km	10km	40km
Center wavelength	850nm	1310nm	1310nm
Transmitting power	-9.5dBm~ -2.5dBm	-9.0dBm~ -3.0dBm	-5.0dBm~0dBm
Receiver sensitivity	-17.0dBm	-20.0dBm	-23.0dBm
Type of the optical connector	LC	LC	LC
Fiber type	Multi mode	Single mode	Single mode

Table 4-3 Attributes of the ESFP (GE) optical module

Attribute	Specification	
Transmission distance	RTXM191-502 PT7620-51-3W	FTLF1619P1BCL
Distance	80km	100km
Center wavelength	1550nm	1550nm
Transmitting power	-2.0dBm~5.0dBm	0dBm~5.0dBm

Attribute	Specification	
Receiver sensitivity	-23.0dBm	-30.0dBm
Type of the optical connector	LC	LC
Fiber type	Single mode	Single mode

4.3 System Performance

Table 4-4 System Performance

Item	Parameter
Switching capacity	<ul style="list-style-type: none"> • S1700-8-AC: 1.6Gbps • S1700-8G-AC: 16Gbps • S1700-24-AC: 4.8Gbps • S1700-52R-2T2P-AC: 17.6Gbps
EEPROM	<ul style="list-style-type: none"> • S1700-8-AC: 4K bits • S1700-8G-AC: 64K bits • S1700-24-AC: 4K bits • S1700-52R-2T2P-AC: 4K bits