



**Quidway S5700 Series Ethernet Switches
V100R006C01**

Hardware Description

Issue 02
Date 2011-11-21

Copyright © Huawei Technologies Co., Ltd. 2011. All rights reserved.

No part of this document may be reproduced or transmitted in any form or by any means without prior written consent of Huawei Technologies Co., Ltd.

Trademarks and Permissions



HUAWEI and other Huawei trademarks are trademarks of Huawei Technologies Co., Ltd.

All other trademarks and trade names mentioned in this document are the property of their respective holders.

Notice

The purchased products, services and features are stipulated by the contract made between Huawei and the customer. All or part of the products, services and features described in this document may not be within the purchase scope or the usage scope. Unless otherwise specified in the contract, all statements, information, and recommendations in this document are provided "AS IS" without warranties, guarantees or representations of any kind, either express or implied.

The information in this document is subject to change without notice. Every effort has been made in the preparation of this document to ensure accuracy of the contents, but all statements, information, and recommendations in this document do not constitute the warranty of any kind, express or implied.

Huawei Technologies Co., Ltd.

Address: Huawei Industrial Base
Bantian, Longgang
Shenzhen 518129
People's Republic of China

Website: <http://www.huawei.com>

Email: support@huawei.com

About This Document

Intended Audience

This document provides an overall description of the S5700, details about each chassis and board, cables available to the device, and lists of components.





This document describes hardware features of the S5700, which helps intended readers obtain detailed information about each chassis, board, and cable, and rapidly locate specific information through lists of components.

This document is intended for:

- Network planning engineers
- Hardware installation engineers
- Commissioning engineers
- On-site maintenance engineers
- System maintenance engineers

Symbol Conventions

The symbols that may be found in this document are defined as follows.

Symbol	Description
 DANGER	Indicates a hazard with a high level of risk, which if not avoided, will result in death or serious injury.
 WARNING	Indicates a hazard with a medium or low level of risk, which if not avoided, could result in minor or moderate injury.
 CAUTION	Indicates a potentially hazardous situation, which if not avoided, could result in equipment damage, data loss, performance degradation, or unexpected results.
 TIP	Indicates a tip that may help you solve a problem or save time.
 NOTE	Provides additional information to emphasize or supplement important points of the main text.

Change History

Updates between document issues are cumulative. Therefore, the latest document issue contains all updates made in previous issues.

Changes in Issue 02 (2011-11-21)

Based on issue 01 (2011-10-26), the document is updated as follows:

The documentation is modified according to updates in product features.

Changes in Issue 01 (2011-10-26)

Initial commercial release.

Contents

About This Document.....	ii
1 Overview of the S5700.....	1
1.1 Introduction.....	2
1.1.1 Positioning.....	2
1.1.2 Product Characteristics.....	2
1.2 S5700 Device Models and Naming Rules.....	3
1.3 Device Structure.....	7
1.4 ESD Jack.....	12
1.5 System Configuration.....	13
1.6 Physical Specifications.....	14
2 Power Supply Unit.....	17
2.1 Power Supply Configuration.....	19
2.2 Power Supply Unit Working Mode.....	21
2.2.1 Working Mode of DC Power Supply Units.....	21
2.2.2 Working Mode of Non-PoE AC Power Supply Units.....	21
2.2.3 Working Mode of PoE AC Power Supply Units.....	22
2.3 150 W DC Power Supply Units.....	23
2.3.1 Function Overview.....	23
2.3.2 Panel.....	23
2.3.3 Technical Specifications.....	24
2.4 150 W AC Power Supply Units.....	25
2.4.1 Function Overview.....	25
2.4.2 Panel.....	26
2.4.3 Technical Specifications.....	26
2.5 170 W DC Power Supply Units.....	27
2.5.1 Function Overview.....	27
2.5.2 Panel.....	27
2.5.3 Technical Specifications.....	28
2.6 170 W AC Power Supply Units.....	29
2.6.1 Function Overview.....	29
2.6.2 Panel.....	29
2.6.3 Technical Specifications.....	30

2.7 AC PoE Power Supply Units.....	30
2.7.1 Function Overview.....	31
2.7.2 Panel.....	31
2.7.3 Technical Specifications.....	32
3 Heat Dissipation System.....	34
3.1 Heat Dissipation Mode.....	35
3.2 Fan Module.....	37
4 Interface Subcards.....	39
4.1 Introduction.....	41
4.1.1 Interface Subcard Types.....	41
4.1.2 Interface Numbering.....	42
4.2 E2XX-2-Port 10GE XFP Optical Interface Subcard.....	43
4.2.1 Functions and Applications.....	43
4.2.2 Panel.....	44
4.2.3 Interfaces.....	44
4.2.4 Interface Attributes.....	45
4.2.5 Technical Specifications.....	45
4.3 E2XY-2-Port 10GE SFP+ Optical Interface Subcard.....	45
4.3.1 Functions and Applications.....	46
4.3.2 Panel.....	46
4.3.3 Interfaces.....	47
4.3.4 Interface Attributes.....	47
4.3.5 Technical Specifications.....	47
4.4 E4GF/E4GFA-4-Port GE Optical Interface Subcard.....	48
4.4.1 Functions and Applications.....	48
4.4.2 Panel.....	48
4.4.3 Interfaces.....	50
4.4.4 Interface Attributes.....	50
4.4.5 Technical Specifications.....	51
4.5 E4XY-4-Port 10GE SFP+ Optical Interface Subcard.....	51
4.5.1 Functions and Applications.....	51
4.5.2 Panel.....	52
4.5.3 Interfaces.....	52
4.5.4 Interface Attributes.....	53
4.5.5 Technical Specifications.....	53
4.6 X2SA/X4SA-2/4-Port GE SFP/10G SFP+ Optical Interface Subcard.....	53
4.6.1 Functions and Applications.....	53
4.6.2 Panel.....	54
4.6.3 Interfaces.....	54
4.6.4 Interface Attributes.....	55
4.6.5 Technical Specifications.....	55
4.7 G4SC-4-Port GE SFP Optical Interface Subcard.....	56

4.7.1 Functions and Applications.....	56
4.7.2 Panel.....	56
4.7.3 Interfaces.....	57
4.7.4 Interface Attributes.....	57
4.7.5 Technical Specifications.....	57
4.8 ETPC-Stack Rear Subcard.....	58
4.8.1 Functions and Applications.....	58
4.8.2 Appearance.....	58
4.8.3 Interfaces.....	59
4.8.4 Technical Specifications.....	59
4.9 ETPB-Extended Rear Subcard.....	59
4.9.1 Functions and Applications.....	59
4.9.2 Appearance.....	60
4.9.3 Technical Specifications.....	60
5 Cables.....	61
5.1 DC Power Cables.....	62
5.2 AC Power Cables.....	63
5.3 Ground Cables.....	65
5.4 Console Cables.....	66
5.5 Network Cables.....	67
5.6 Optical Fibers.....	70
5.7 Stack cables.....	74
6 List of Indicators.....	76
6.1 Indicators on the Front Panel.....	77
6.2 Fan Indicators.....	86
6.3 Power Indicators.....	87
7 List of Optical Modules.....	93
7.1 ESFP Optical Module (FE) Attributes.....	94
7.2 ESFP Optical Module (GE) Attributes.....	94
7.3 ESFP CWDM-SFP Optical Module.....	95
7.4 XFP Optical Module (10GE) Attributes.....	96
7.5 SFP+ Optical Module (10GE) Attributes.....	97

1 Overview of the S5700

About This Chapter

[1.1 Introduction](#)

This section describes the characteristics of the S5700.

[1.2 S5700 Device Models and Naming Rules](#)

This section describes device models and naming rules of the S5700.

[1.3 Device Structure](#)

This section describes the structure of the S5700.

[1.4 ESD Jack](#)

This section describes the functions of the ESD jack on the S5700.

[1.5 System Configuration](#)

[1.6 Physical Specifications](#)

1.1 Introduction

This section describes the characteristics of the S5700.

1.1.1 Positioning



WARNING

The Quidway S5700 Ethernet switches are class A products. Customers should take preventative measures as the operating devices may cause radio interference.

The Quidway S5700 switch (S5700 for short) is an enterprise networks access device that provides access and data transport functions. The S5700 is developed by Huawei to meet the requirements for reliable access, aggregation, and high-quality transmission of multiple services on an enterprise networks . The S5700 functions as the access device of the enterprise networks. The S5700 provides large capacity, high port density, and cost-effective packet forwarding capabilities. The S5700 also provides multi-service access capabilities, excellent extensibility, quality of service (QoS) guarantee, powerful multicast replication, and carrier-class security, and can be used to build high-reliability ring topologies.

NOTE

The S5700-6TP-LI-AC does not support hardware forwarding of Layer 3 services.

1.1.2 Product Characteristics

Energy-Saving Design

The S5700 saves energy in the following ways:

- It uses low noise fans that adjust their speed automatically, reducing system noise and fan power consumption.
- The interface chip switches to the power saving mode when an interface is idle, which means that no peer device is connected to the interface.
- It uses advanced highly-integrated and energy-saving chips. With the help of the intelligent device management system, the chips improve system performance and also reduce system power consumption.

Advanced Surge Protection Technique

The S5700 uses the Huawei patented built-in surge protection technique. This technique protects devices against lightning in terrible weather and increases device security.

Convenient PoE Power Supply

The S5700 has the Power over Ethernet (PoE) function. It provides centralized power supply for IP phones, wireless access points (APs), portable device chargers, POS machines, cameras, and data collectors by using twisted pairs.

Complying with IEEE 802.3af and IEEE 802.3at, the PoE S5700 is able to remotely provide power for the devices of different vendors. IEEE 802.3at delivers a maximum of 30 W power. This allows IEEE 802.3at to support IP video phones, dualband WiFi APs, IP cameras, multi-function STBs, and RFIDs, and simplifies the network.

The S5700 has the ability to control power supply based on time range, which effectively manages network devices, reduces power consumption, and lowers the OPEX.

1.2 S5700 Device Models and Naming Rules

This section describes device models and naming rules of the S5700.

Device Models

To meet diverse customer requirements, the S5700 provides a variety of models. [Table 1-1](#) lists these device models.

You can select a device model as required.

Table 1-1 Device models

Product Series	Model	Maximum Number of Interfaces
S5700 C	S5700-28C-EI	28 There are twenty-four 10/100/1000BASE-T Ethernet interfaces and four interfaces on the front subcard.
	S5700-28C-EI-24S	28 There are twenty-four 100/1000BASE-X Ethernet optical interfaces, four GE combo interfaces (10/100/1000BASE-T+100/1000BASE-X, used together with the last four Ethernet interfaces), and four interfaces on the front subcard.
	S5700-52C-EI	52 There are forty-eight 10/100/1000BASE-T Ethernet interfaces and four interfaces on the front subcard.
	S5700-28C-PWR-EI	28 There are twenty-four 10/100/1000BASE-T Ethernet interfaces and four interfaces on the front subcard.
	S5700-52C-PWR-EI	52 There are forty-eight 10/100/1000BASE-T Ethernet interfaces and four interfaces on the front subcard.

Product Series	Model	Maximum Number of Interfaces
	S5700-28C-SI	28 There are twenty-four 10/100/1000BASE-T Ethernet interfaces, four GE combo interfaces (10/100/1000BASE-T+100/1000BASE-X, used together with the last four Ethernet interfaces), and four interfaces on the front subcard.
	S5700-52C-SI	52 There are forty-eight 10/100/1000BASE-T Ethernet interfaces and four interfaces on the front subcard.
	S5700-28C-HI-24S	28 There are twenty-four 100/1000BASE-X Ethernet optical interfaces and four interfaces on the front subcard.
	S5700-28C-HI	28 There are twenty-four 10/100/1000BASE-T Ethernet interfaces and four interfaces on the front subcard.
S5700TP	S5700-24TP-SI-AC	24 There are twenty-four 10/100/1000BASE-T Ethernet interfaces and four GE combo interfaces (10/100/1000BASE-T+100/1000BASE-X, used together with the last four Ethernet interfaces).
	S5700-24TP-SI-DC	24 There are twenty-four 10/100/1000BASE-T Ethernet interfaces and four GE combo interfaces (10/100/1000BASE-T+100/1000BASE-X, used together with the last four Ethernet interfaces).
	S5700-48TP-SI-AC	48 There are forty-eight 10/100/1000BASE-T Ethernet interfaces and four GE combo interfaces (10/100/1000BASE-T+100/1000BASE-X, used together with the last four Ethernet interfaces).
	S5700-48TP-SI-DC	48 There are forty-eight 10/100/1000BASE-T Ethernet interfaces and four GE combo interfaces (10/100/1000BASE-T+100/1000BASE-X, used together with the last four Ethernet interfaces).

Product Series	Model	Maximum Number of Interfaces
	S5700-24TP-PWR-SI	24 There are twenty-four 10/100/1000BASE-T Ethernet interfaces and four GE combo interfaces (10/100/1000BASE-T+100/1000BASE-X, used together with the last four Ethernet interfaces).
	S5700-48TP-PWR-SI	48 There are forty-eight 10/100/1000BASE-T Ethernet interfaces and four GE combo interfaces (10/100/1000BASE-T+100/1000BASE-X, used together with the last four Ethernet interfaces).
	S5700-6TP-LI-AC	6 There are four 10/100/1000BASE-T Ethernet interfaces and two GE combo interfaces (10/100/1000BASE-T+100/1000BASE-X).

Naming Rules

The following are the naming rules of the S5700-6TP-LI-AC, S5700-48TP-PWR-SI, S5700-28C-EI-24S and S5700-28C-HI.

Figure 1-1 Naming rules

Quidway S5700-6TP-LI-AC

A B C D E G I

Quidway S5700-48TP-PWR-SI

D F G

Quidway S5700-28C-EI-24S

D E G H

Quidway S5700-28C-HI

G

Identifier	Description
A	Product brand.
B	Switch.
C	Product series. "57" indicates the S5700 series.
D	Maximum number of interfaces. NOTE The number of interfaces on an S5700 can be 6, 24, 28, 48, or 52, depending on the device model.
E	Uplink interface type: <ul style="list-style-type: none"> ● C: A device supports interface cards. There can be two or four uplink interfaces on an interface subcard. ● TP: A device has combo interfaces supporting optical and electrical interfaces.
F	The S5700 supports Power over Ethernet (PoE). NOTE If this letter is not displayed, PoE is not supported.

Identifier	Description
G	Software version type: <ul style="list-style-type: none"> ● EI: enhanced version, supporting enhanced features ● SI: standard version, supporting basic features ● HI: advanced version, supporting high-performance Operation, Administration, and Maintenance (OAM) and built-in real-time clock (RTC) ● LI: simplified version
H	Downlink interface type. The value 24S indicates that 24 downlink interfaces of the S5700-28C-EI-24S are optical interfaces. NOTE If this letter is not displayed, all downlink interfaces are electrical interfaces.
I	Powering mode: <ul style="list-style-type: none"> ● AC: alternating current power ● DC: direct current power

1.3 Device Structure

This section describes the structure of the S5700.

The S5700 Ethernet switches adopt an integrated hardware platform. An S5700 consists of the chassis, power supply unit, fan, switch control unit (SCU), and interface subcard. The width of an S5700 complies with industry standards, and the S5700 can be installed in an IEC297 cabinet or an ETSI cabinet.

The S5700 switches include S5700C and S5700TP.

 **NOTE**

The S5700 is 1 U (1 U = 44.45 mm) high.

- The dimensions of S5700-24TP-SI-AC, S5700-24TP-SI-DC, S5700-28C-HI or S5700-28C-HI-24S are 442.0 mm x 220.0 mm x 43.6 mm (width x depth x height).
- The dimensions of S5700-6TP-LI-AC are 250.0 mm × 180.0 mm × 43.6 mm (width x depth x height).
- The dimensions of an S5700 switch except S5700-24TP-SI-AC, S5700-24TP-SI-DC, S5700-28C-HI, S5700-28C-HI-24S and S5700-6TP-LI-AC are 442.0 mm x 420.0 mm x 43.6 mm (width x depth x height).

S5700C Appearances

[Table 1-2](#) shows the front views of S5700C.

Table 1-2 S5700C front views

Model	Image
S5700-28C -EI-24S	<p>Diagram showing the front view of the S5700-28C-EI-24S switch. Callout 1 points to the 24 SFP ports, callout 2 points to the 24 RJ45 ports, and callouts 5, 6, and 7 point to the management ports (console, AUX, and Ethernet).</p>
S5700-28C -EI	<p>Diagram showing the front view of the S5700-28C-EI switch. Callout 3 points to the 24 RJ45 ports, and callouts 5, 6, and 7 point to the management ports.</p>
S5700-28C -PWR-EI	<p>Diagram showing the front view of the S5700-28C-PWR-EI switch. Callout 3 points to the 24 RJ45 ports, and callouts 5, 6, and 7 point to the management ports.</p>
S5700-28C -SI	<p>Diagram showing the front view of the S5700-28C-SI switch. Callout 3 points to the 24 RJ45 ports, callout 2 points to the 24 SFP ports, and callouts 5, 6, 8, and 7 point to the management ports.</p>
S5700-52C -EI	<p>Diagram showing the front view of the S5700-52C-EI switch. Callout 4 points to the 52 RJ45 ports, and callouts 5, 6, and 7 point to the management ports.</p>
S5700-52C -PWR-EI	<p>Diagram showing the front view of the S5700-52C-PWR-EI switch. Callout 4 points to the 52 RJ45 ports, and callouts 5, 6, and 7 point to the management ports.</p>
S5700-52C -SI	<p>Diagram showing the front view of the S5700-52C-SI switch. Callout 4 points to the 52 RJ45 ports, and callouts 5, 6, 8, and 7 point to the management ports.</p>
S5700-28C -HI	<p>Diagram showing the front view of the S5700-28C-HI switch. Callout 9 points to the power input, callout 7 points to the power output, callout 3 points to the 24 RJ45 ports, and callouts 10, 5, 6, and 8 point to the management ports.</p>
S5700-28C -HI-24S	<p>Diagram showing the front view of the S5700-28C-HI-24S switch. Callout 9 points to the power input, callout 7 points to the power output, callout 1 points to the 24 SFP ports, and callouts 10, 5, 6, and 8 point to the management ports.</p>

1. Twenty-four 100/1000BASE-X Ethernet optical interfaces	2. Four GE combo interfaces (10/100/1000BASE-T+100/1000BASE-X, used together with the last four Ethernet interfaces)	3. Twenty-four 10/100/1000BASE-T Ethernet interfaces	4. Forty-eight 10/100/1000BASE-T Ethernet interfaces
5. One console interface	6. One management interface	7. Front subcard slot	8. One USB interface
9. Power supply unit slot	10. ESD jack		

NOTE

By default, a combo interface works in the auto mode. In the auto mode, if the electrical interface is connected to a network cable first, the combo interface works as an electrical interface to transmit data; if the optical interface is connected to a fiber first, the combo interface works as an optical interface to transmit data.

S5700-28C-EI-24S support 1000BASE-T Copper SFP Transceiver.

Table 1-3 shows the rear views of S5700C.

Table 1-3 S5700C rear views

Model	Image
S5700-28C-EI-24S S5700-28C-EI S5700-28C-SI S5700-52C-EI S5700-52C-SI	
S5700-28C-PWR-EI S5700-52C-PWR-EI	

Model	Image
S5700-28C -HI S5700-28C -HI-24S	

1. ESD jack	2. Rear subcard slot	3. Fan module	4. Power supply unit slot
5. Two monitor interfaces	6. Two ground screws		

S5700TP Appearances

Table 1-4 shows the front views of S5700TP.

Table 1-4 S5700TP front views

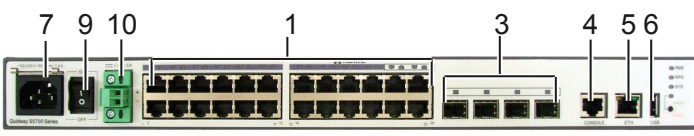
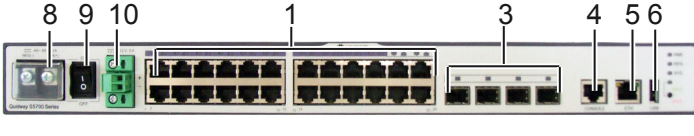
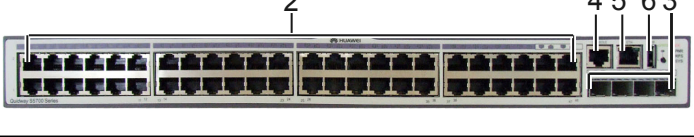
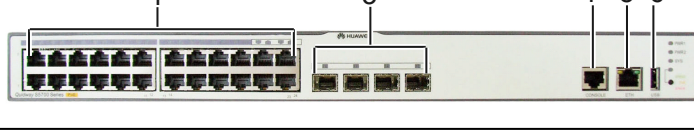
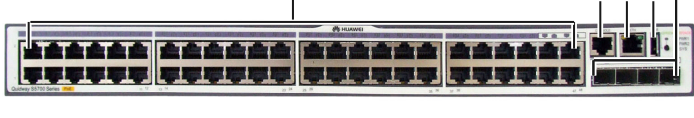
Model	Image
S5700-24T P-SI-AC	
S5700-24T P-SI-DC	
S5700-48T P-SI-AC S5700-48T P-SI-DC	
S5700-24T P-PWR-SI	
S5700-48T P-PWR-SI	

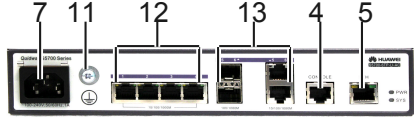
Model	Image
S5700-6TP -LI-AC	

1. Twenty-four 10/100/1000BASE-T Ethernet interfaces	2. Forty-eight 10/100/1000BASE-T Ethernet interfaces	3. Four GE combo interfaces (10/100/1000BASE-T+100/1000BASE-X, used together with the last four Ethernet interfaces)	4. One console interface
5. One management interface	6. One USB interface	7. AC jack	8. DC jack
9. Switch	10. RPS power jack	11. Ground screw	12. Four 10/100/1000BASE-T Ethernet interfaces
13. Two 1000M combo interfaces (10/100/1000BASE-T+100/1000BASE-X)			





 **NOTE**

By default, a combo interface works in the auto mode. In the auto mode, if the electrical interface is connected to a network cable first, the combo interface works as an electrical interface to transmit data; if the optical interface is connected to a fiber first, the combo interface works as an optical interface to transmit data.

Table 1-5 shows the rear views of S5700TP.

Table 1-5 S5700TP rear views

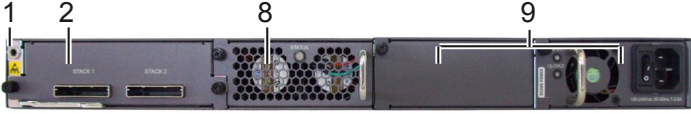
Model	Image
S5700-24T P-SI-AC S5700-24T P-SI-DC	

Model	Image
S5700-48T P-SI-AC	
S5700-48T P-SI-DC	
S5700-24T P-PWR-SI S5700-48T P-PWR-SI	
S5700-6TP -LI-AC	

1. ESD jack	2. Rear subcard slot	3. RPS power jack	4. Ground screw	5. Switch
6. AC jack	7. DC jack	8. Fan module	9. Power supply unit slot	10. Security lock

1.4 ESD Jack

This section describes the functions of the ESD jack on the S5700.

The S5700 has an electromagnetic discharge (ESD) jack on the chassis.

When installing the S5700, wear an ESD wrist strap. Connect the ESD wrist strap to the ESD jack on the chassis, as shown in [Figure 1-2](#).

Figure 1-2 ESD jack

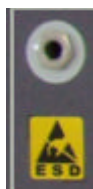

NOTE

S5700-6TP-LI-AC does not have any ESD jack. The ESD jacks of S5700-28C-HI and S5700-28C-HI-24S are located on the front side of the chassis; the ESD jacks of other models are located on the rear side of the chassis.

1.5 System Configuration

Table 1-6 System configuration

Item	Parameter
Processor	S5700C-EI: 533 MHz S5700C-SI: 800 MHz S5700TP-SI: 800 MHz S5700C-HI: 1GHz S5700-6TP-LI-AC: 1GHz
Switching capacity	<ul style="list-style-type: none"> ● S5700-24TP: 48 Gbit/s ● S5700-28C-SI/EI/HI: 128 Gbit/s ● S5700-48TP: 96 Gbit/s ● S5700-52C-SI/EI: 176 Gbit/s ● S5700-6TP-LI-AC: 12Gbit/s
Packet forwarding capacity	<ul style="list-style-type: none"> ● S5700-24TP: 35.71 Mpps ● S5700-28C-SI/EI/HI: 95.2 Mpps ● S5700-48TP: 71.42 Mpps ● S5700-52C-SI/EI: 130.94 Mpps ● S5700-6TP-LI-AC: 8.9Mpps
DDR memory	512M for S5700C-HI and S5700-6TP-LI-AC, and 256 MB for others
Flash Memory	64M for S5700C-HI and S5700-6TP-LI-AC, and 32 MB for others

1.6 Physical Specifications

Table 1-7 Physical specifications

Item	Description
Dimensions (width x depth x height)	<ul style="list-style-type: none"> ● S5700-24TP-SI-AC: 442.0 mm x 220.0 mm x 43.6 mm ● S5700-24TP-SI-DC: 442.0 mm x 220.0 mm x 43.6 mm ● S5700-28C-EI-24S: 442.0 mm x 420.0 mm x 43.6 mm ● S5700-28C-EI: 442.0 mm x 420.0 mm x 43.6 mm ● S5700-28C-PWR-EI: 442.0 mm x 420.0 mm x 43.6 mm ● S5700-28C-SI: 442.0 mm x 420.0 mm x 43.6 mm ● S5700-52C-EI: 442.0 mm x 420.0 mm x 43.6 mm ● S5700-52C-PWR-EI: 442.0 mm x 420.0 mm x 43.6 mm ● S5700-52C-SI: 442.0 mm x 420.0 mm x 43.6 mm ● S5700-48TP-SI-AC: 442.0 mm x 420.0 mm x 43.6 mm ● S5700-48TP-SI-DC: 442.0 mm x 420.0 mm x 43.6 mm ● S5700-24TP-PWR-SI: 442.0 mm x 420.0 mm x 43.6 mm ● S5700-48TP-PWR-SI: 442.0 mm x 420.0 mm x 43.6 mm ● S5700-28C-HI: 442.0mm×220.0mm×43.6mm ● S5700-28C-HI-24S: 442.0mm×220.0mm×43.6mm ● S5700-6TP-LI-AC: 250.0mm×180.0mm×43.6mm

Item		Description
Maximum power (full configuration)		<ul style="list-style-type: none"> ● S5700-28C-EI: 60W ● S5700-52C-EI: 88W ● S5700-28C-EI-24S: 63W ● S5700-28C-SI: 56W ● S5700-52C-SI: 78W ● S5700-24TP-SI-AC: 40W ● S5700-24TP-SI-DC: 40W ● S5700-48TP-SI-AC: 64W ● S5700-48TP-SI-DC: 64W ● S5700-24TP-PWR-SI: 455 W (Dissipated power: 85 W, PoE: 370 W) ● S5700-48TP-PWR-SI: 907 W (Dissipated power: 167 W, PoE: 740 W) ● S5700-28C-PWR-EI: 842 W (Dissipated power: 102 W, PoE: 740 W) ● S5700-52C-PWR-EI: 930 W (Dissipated power: 190 W, PoE: 740 W) ● S5700-28C-HI: 89W ● S5700-28C-HI-24S: 91.6W ● S5700-6TP-LI-AC: 30W
Weight	Full configuration	≤ 8.5 kg
	Empty chassis	≤ 5 kg
DC input voltage	Rated voltage	-48V DC to -60V DC
	Maximum voltage	-36V DC to -72V DC
AC input voltage	Rated voltage	100V AC to 240V AC
	Maximum voltage	90V AC to 264V AC
Temperature	operating temperature	S5300SI, S5300EI: 0°C to 50°C S5700-6TP-LI-AC: -5°C to 55°C (Altitude: 0 m to 2000 m); S5700HI: -5°C to 55°C (Altitude: 0 m to 1800 m) NOTE <ul style="list-style-type: none"> ● For S5700HI, if using 40km SFP+ optical module, the operating temperature of S5700HI is between -5°C and 45°C.
	Storage temperature	-40°C to 70°C
Relative humidity		10%RH to 90%RH

Item	Description
Altitude	S5706TP-LI-AC: 0 m to 2000 m S5700SI\S5700EI: 0 m to 2000 m S5700HI: 0 m to 4000 m

2 Power Supply Unit

About This Chapter

This chapter describes the AC and DC power supply units of the S5700.



CAUTION

- Only the power supply units of the same power can be used on an S5700.
 - Power off the S5700 before removing the power supply units. Do not operate the power supply units when the S5700 is running.
 - Before powering off the S5700, shut down all its power supply units.
-

[2.1 Power Supply Configuration](#)

This section describes the power supply configuration on the S5700.

[2.2 Power Supply Unit Working Mode](#)

This section describes the working mode of S5700 power supply units.

[2.3 150 W DC Power Supply Units](#)

This section describes the functions, appearance, switch, indicators, and technical specifications of the S5700 150 W DC power supply unit.

[2.4 150 W AC Power Supply Units](#)

This section describes the functions, appearance, switch, indicators, and technical specifications of the S5700 150 W AC power supply unit.

[2.5 170 W DC Power Supply Units](#)

This section describes the functions, appearance, switch, indicators, and technical specifications of the S5700 170 W DC power supply unit.

[2.6 170 W AC Power Supply Units](#)

This section describes the functions, appearance, switch, indicators, and technical specifications of the S5700 170 W AC power supply unit.

[2.7 AC PoE Power Supply Units](#)

This section describes the functions, appearance, switch, indicators, and technical specifications of the S5700 AC PoE power supply unit.

2.1 Power Supply Configuration

This section describes the power supply configuration on the S5700.

PoE Power Supply

The downlink electrical interfaces of S5700 PoE switches provide PoE power. Each interface provides a maximum of 30 W power and supports a maximum of 100 m power supply distance. The S5700 can transmit both current and data on a pair of signal cables.

PoE power supply units are classified into two types: 500 W current sharing power supply and 250 W current sharing power supply.

Power Supply Unit	PoE Power	Device Power
500 W current sharing power supply	369.6 W	120 W
250 W current sharing power supply	123.2 W	120 W

The S5700 PoE switches include:

- S5700-48TP-PWR-SI and S5700-52C-PWR-EI:

Each switch provides two power supply unit slots. Each slot accommodates a 500 W or 250 W power supply unit. The power supply configurations are shown in the following table.

Power Supply Unit		PoE Power	Maximum Number of Interfaces
250 W current sharing power supply	-	123.2 W	<ul style="list-style-type: none"> ● 802.3af: 8 ● 802.3at: 4
500 W current sharing power supply	-	369.6 W	<ul style="list-style-type: none"> ● 802.3af: 24 ● 802.3at: 12
250 W current sharing power supply	250 W current sharing power supply	246.4 W	<ul style="list-style-type: none"> ● 802.3af: 16 ● 802.3at: 8
500 W current sharing power supply	500 W current sharing power supply	739.2 W	<ul style="list-style-type: none"> ● 802.3af: 48 ● 802.3at: 24

- S5700-28C-PWR-EI:

Each switch provides two power supply unit slots. Each slot accommodates a 500 W or 250 W power supply unit. The power supply configurations are shown in the following table.

Power Supply Unit		PoE Power	Maximum Number of Interfaces
250 W current sharing power supply	-	123.2 W	<ul style="list-style-type: none"> ● 802.3af: 8 ● 802.3at: 4
500 W current sharing power supply	-	369.6 W	<ul style="list-style-type: none"> ● 802.3af: 24 ● 802.3at: 12
250 W current sharing power supply	250 W current sharing power supply	246.4 W	<ul style="list-style-type: none"> ● 802.3af: 16 ● 802.3at: 8
500 W current sharing power supply	500 W current sharing power supply	739.2 W	<ul style="list-style-type: none"> ● 802.3af: 24 ● 802.3at: 24

● S5700-24TP-PWR-SI:

Each switch provides two power supply unit slots. Each slot accommodates a 500 W or 250 W power supply unit. The power supply configurations are shown in the following table.

Power Supply Unit		PoE Power	Maximum Number of Interfaces
250 W current sharing power supply	-	123.2 W	<ul style="list-style-type: none"> ● 802.3af: 8 ● 802.3at: 4
500 W current sharing power supply	-	369.6 W	<ul style="list-style-type: none"> ● 802.3af: 24 ● 802.3at: 12
250 W current sharing power supply	250 W current sharing power supply	246.4 W	<ul style="list-style-type: none"> ● 802.3af: 16 ● 802.3at: 8
500 W current sharing power supply	500 W current sharing power supply	369.6 W	<ul style="list-style-type: none"> ● 802.3af: 24 ● 802.3at: 12

 **NOTE**

Current sharing indicates that the power of two power supply units can be accumulated for PDs. The power for the device cannot be accumulated.

When two power supply units are used, they work in redundancy backup mode to provide power for the device and in load balancing mode to provide power for PDs.

Non-PoE Power Supply Configuration

On a non-PoE switch, one or two power supply units can be configured.

When two power supply units are used, they work in 1:1 backup mode to provide power for the device.

 **NOTE**

The power supply units of S5700-6TP-LI-AC, S5700-24TP-SI-AC, S5700-24TP-SI-DC, S5700-48TP-SI-AC and S5700-48TP-SI-DC are not hot swappable.

The S5700-24TP-SI-AC, S5700-24TP-SI-DC, S5700-48TP-SI-AC and S5700-48TP-SI-DC support redundancy power supply (RPS).

The AC power supply and the DC power supply can be configured on an S5700-28C-HI or S5700-28C-HI-24S.

2.2 Power Supply Unit Working Mode

This section describes the working mode of S5700 power supply units.

2.2.1 Working Mode of DC Power Supply Units

Figure 2-1 Working mode of DC power supply units

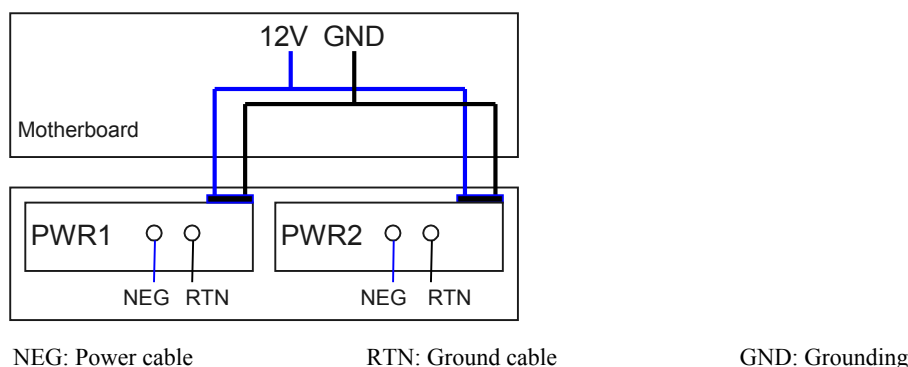

After the DC power is transmitted to the PWR module, the PWR module outputs 12 V voltage, and then the motherboard provides power for the entire device.

2.2.2 Working Mode of Non-PoE AC Power Supply Units

The working mode of the S5700 non-PoE AC power supply units is shown in [Figure 2-2](#) and [Figure 2-3](#).

Figure 2-2 Working mode of non-PoE AC power supply units

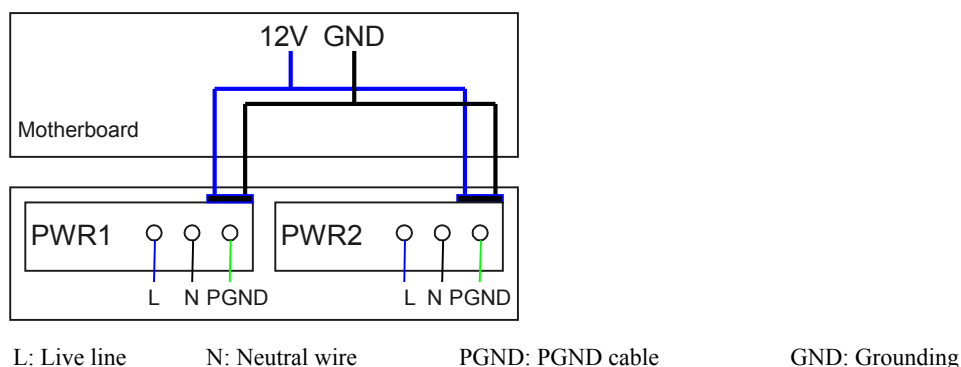

After the AC power is transmitted to the PWR module except S5700-6TP-LI-AC, S5700-24TP-SI-AC and S5700-48TP-SI-AC, the PWR module outputs 12 V voltage, and then the motherboard provides power for the entire device.

Figure 2-3 Working mode of a non-PoE AC power supply unit that functions alone

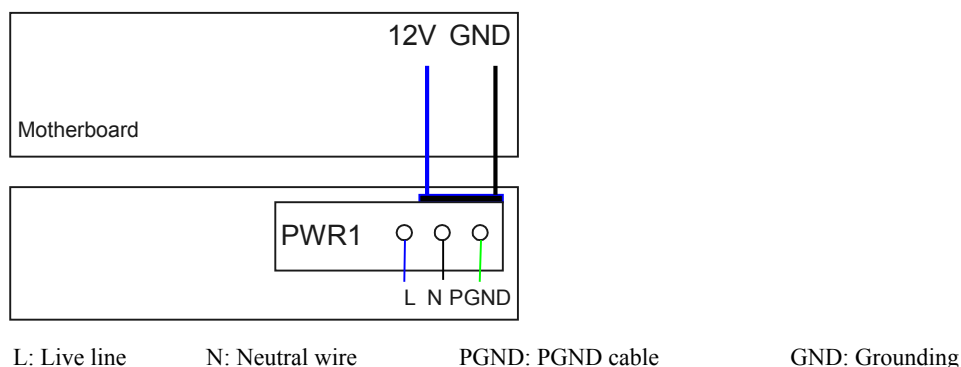

On a switch on the S5700-6TP-LI-AC, S5700-24TP-SI-AC and S5700-48TP-SI-AC, after the AC power is transmitted to the PWR module, the PWR module outputs 12 V voltage, and provides power for the entire device.

2.2.3 Working Mode of PoE AC Power Supply Units

The working mode of S5700 PoE AC power supply units is shown in [Figure 2-4](#).

Figure 2-4 Working mode of PoE AC power supply units

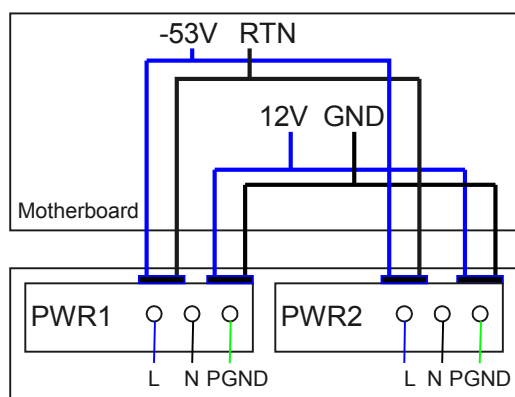

L: Live line N: Neutral wire PGND: PGND cable GND: Grounding RTN: Ground cable

After the PoE power is transmitted to the PWR module, the PWR module outputs 12 V and -53 V voltage, and then the motherboard provides 12 V voltage for the entire device and -53 V voltage for the powered devices (PDs).

2.3 150 W DC Power Supply Units

This section describes the functions, appearance, switch, indicators, and technical specifications of the S5700 150 W DC power supply unit.

2.3.1 Function Overview

The 150 W DC power supply unit provides +12 V DC power. It has the following functions:

- EMC filtering, surge protection, and short circuit protection.
- Various alarms, for example, the alarm triggered when there is no power input, the alarm for air breaker status, the alarm for invalid surge protection, and the alarm for undervoltage input.



NOTE

Only S5700-28C-EI, S5700-28C-EI-24S, S5700-52C-EI, S5700-28C-SI, and S5700-52C-SI support the 150 W DC power supply unit.

2.3.2 Panel



NOTE

The power supply units of S5700-24TP-SI-DC and S5700-48TP-SI-DC are integrated on the switch control unit (SCU). They do not support power modules. The functions of the power supply unit switch are the same as the functions of the power module switch. The power supply units of S5700-24TP-SI-DC and S5700-48TP-SI-DC do not have the status indicators. For the status and meanings of power indicators, see the PWR indicator description in section [6.1 Indicators on the Front Panel](#).

Figure 2-5 shows the appearance of the 150 W DC power supply unit.

Figure 2-5 Appearance of the 150 W DC power supply unit

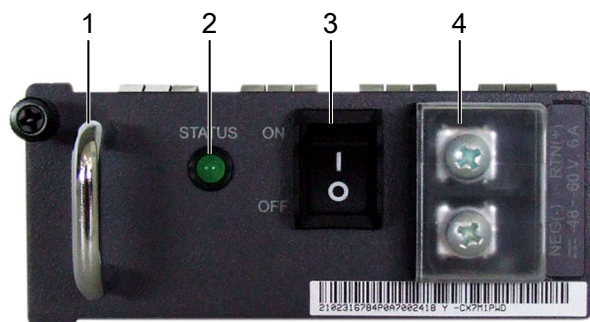

1. Handle

2. Indicator

3. Switch

4. DC jack

Table 2-1 describes the meanings of the indicator.

Table 2-1 Description of the 150 W DC power indicators

Name	Status	Description
STATUS	Off	<ul style="list-style-type: none"> The input power is out of range, for example, no DC input power, DC input overvoltage, and DC input undervoltage. The output power is out of range, for example, undervoltage or overtemperature occurs.
	Green	The DC input power is within range.
	Blinking green	The output power is out of range, for example, overvoltage, overcurrent, or short circuit occurs.

2.3.3 Technical Specifications

Table 2-2 describes the technical specifications of the 150 W DC power supply unit.

Table 2-2 Technical specifications of the DC power supply unit

Item	S5700-28C-EI	S5700-28C-EI-24S	S5700-28C-SI	S5700-52C-EI	S5700-52C-SI
Dimensions (width x depth x height)	100 mm x 220 mm x 43 mm				
Weight	0.8 kg				
Rated input voltage	-60 V DC to -48 V DC				
Maximum input voltage	-72 V DC to -36 V DC				
Maximum input current	6 A				
Maximum output current	12.5 A				
Maximum output power	150 W				

2.4 150 W AC Power Supply Units

This section describes the functions, appearance, switch, indicators, and technical specifications of the S5700 150 W AC power supply unit.

2.4.1 Function Overview

The 150 W AC power supply unit provides the EMC filtering function and protects the device against:

- Output overcurrent
- Output overvoltage
- Output undervoltage
- Input overvoltage
- Input undervoltage
- Overtemperature
- Short circuit
- Lightning

 **NOTE**

Only S5700-28C-EI, S5700-28C-EI-24S, S5700-52C-EI, S5700-28C-SI, and S5700-52C-SI support the 150 W AC power supply unit.

2.4.2 Panel

Figure 2-6 shows the appearance of the AC power supply unit.



NOTE

The power supply units of S5700-24TP-SI-AC and S5700-48TP-SI-AC are integrated on the switch control unit (SCU). They do not support power modules. The functions of the power supply unit switch are the same as the functions of the power module switch. The power supply units of S5700-24TP-SI-AC and S5700-48TP-SI-AC do not have the status indicators. For the status and meanings of power indicators, see the PWR indicator description in section **6.1 Indicators on the Front Panel**.

Figure 2-6 Appearance of the AC power supply unit

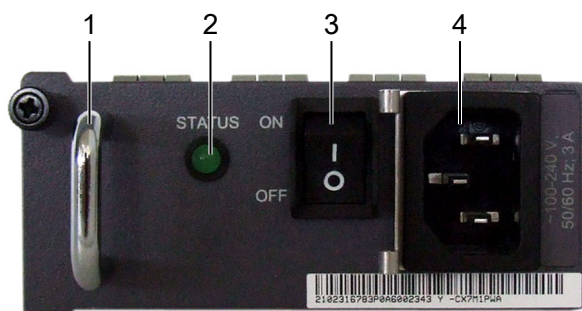

1. Handle

2. Indicator

3. Switch

4. AC jack

Table 2-3 describes the meanings of the indicator.

Table 2-3 Description of the 150 W AC power indicators

Name	Status	Description
STATUS	Off	<ul style="list-style-type: none"> The input power is out of range, for example, no AC input power, AC input overvoltage, and AC input undervoltage. The output power is out of range, for example, undervoltage or overtemperature occurs.
	Green	The AC input power is within range.
	Blinking green	The output power is out of range, for example, overvoltage, overcurrent, or short circuit occurs.

2.4.3 Technical Specifications

Table 2-4 describes the technical specifications of the 150 W AC power supply unit.

Table 2-4 Technical specifications of the AC power supply unit

Item	S5700-28C-EI	S5700-28C-EI-24S	S5700-28C-SI	S5700-52C-EI	S5700-52C-SI
Dimensions (width x depth x height)	100 mm x 220 mm x 43 mm				
Weight	0.8 kg				
Rated input voltage	100 V AC to 240 V AC, 50/60 Hz				
Maximum input voltage	90 V AC to 264 V AC, 47 Hz to 63 Hz				
Maximum input current	3 A				
Maximum output current	12.5 A				
Maximum output power	150 W				

2.5 170 W DC Power Supply Units

This section describes the functions, appearance, switch, indicators, and technical specifications of the S5700 170 W DC power supply unit.

2.5.1 Function Overview

The 170 W DC power supply units are used on S5700-28C-HI and S5700-28C-HI-24S. A power supply unit provides +12 V DC power, and it has the following functions:

- EMC filtering and surge protection
- Protection against reversed connection, input and output overcurrent, input and output overvoltage, short circuit, and overtemperature
- Various alarms, for example, the alarm triggered when there is no power input or output

 **NOTE**

Only S5700-28C-HI and S5700-28C-HI-24S support the 170 W DC power supply unit.

2.5.2 Panel

Figure 2-7 shows the appearance of the 170 W DC power supply unit.

Figure 2-7 Appearance of the 170 W DC power supply unit

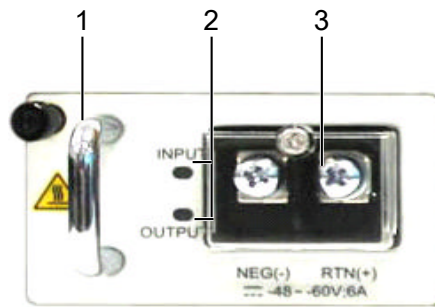

1. Handle

2. Indicator

3. DC jack

Table 2-5 describes the meanings of the indicators.

Table 2-5 Description of the 170 W DC power indicators

Name	Status	Description
INPUT	Green	The DC input power is within range.
	Off	The DC input power is out of range or no DC input power.
OUTPUT	Green	The DC output power is within range.
	Blinking green	The output power is out of range, for example, overvoltage, overcurrent, or short circuit occurs.
	Off	The DC output power is out of range.

2.5.3 Technical Specifications

Table 2-6 describes the technical specifications of the 170 W DC power supply unit.

Table 2-6 Technical specifications of the 170 W DC power supply unit

Item	S5700-28C-HI	S5700-28C-HI-24S
Dimensions (width x depth x height)	195.4 mm x 60.0 mm x 40.0 mm	
Weight	< 0.8 kg	
Rated input voltage range	-60 V DC to -48 V DC	
Maximum input voltage range	-72 V DC to -36 V DC	

Item	S5700-28C-HI	S5700-28C-HI-24S
Maximum input current	6 A	
Maximum output current	14.2 A	
Rated output voltage	12 V	
Maximum output power	170 W	

2.6 170 W AC Power Supply Units

This section describes the functions, appearance, switch, indicators, and technical specifications of the S5700 170 W AC power supply unit.

2.6.1 Function Overview

170 W AC power supply units are used on S5700-28C-HI and S5700-28C-HI-24S. A power supply unit provides +12 V AC power, and it has the following functions:

- EMC filtering and surge protection
- Protection against reversed connection, input and output overcurrent, input and output overvoltage, short circuit, and overtemperature
- Various alarms, for example, the alarm triggered when there is no power input or output

 **NOTE**

Only S5700-28C-HI and S5700-28C-HI-24S support the 170 W AC power supply unit.

2.6.2 Panel

Figure 2-8 shows the appearance of the 170 W AC power supply unit.

Figure 2-8 Appearance of the 170 W AC power supply unit

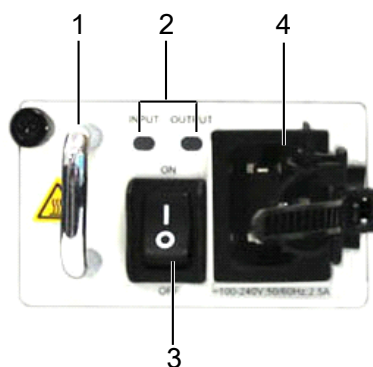

1. Handle

2. Indicator

3. Switch

4. AC jack

Table 2-7 describes the meanings of the indicators.

Table 2-7 Description of the 170 W AC power indicators

Name	Status	Description
INPUT	Green	The AC input power is within range.
	Off	The AC input power is out of range or no AC input power.
OUTPUT	Green	The AC output power is within range.
	Blinking green	The output power is out of range, for example, overvoltage, overcurrent, or short circuit occurs.
	Off	The AC output power is out of range.

2.6.3 Technical Specifications

Table 2-8 describes the technical specifications of the AC power supply unit.

Table 2-8 Technical specifications of the AC power supply unit

Item	S5700-28C-HI	S5700-28C-HI-24S
Dimensions (width x depth x height)	195.4 mm x 60.0 mm x 40.0 mm	
Weight	< 1.0 kg	
Rated input voltage range	100 V AC to 240 V AC, 50/60 Hz	
Maximum input voltage range	90 V AC to 264 V AC, 47 Hz to 63 Hz	
Maximum input current	2.5 A	
Maximum output current	14.2 A	
Rated output voltage	12 V	
Maximum output power	170 W	

2.7 AC PoE Power Supply Units

This section describes the functions, appearance, switch, indicators, and technical specifications of the S5700 AC PoE power supply unit.

2.7.1 Function Overview

Power over Ethernet (PoE) refers to power supply over a 10Base-T, 100Base-TX, or 1000Base-T twisted pair cable.

PoE provides power for terminals such as IP phones, access points (APs), portable device chargers, point-of-sale (POS) machines, cameras, and data collectors. These terminals are powered when they access the network, so the indoor power supply systems are not required. Complying with IEEE 802.3af and IEEE 802.3at, the PoE S5700 is able to remotely provide power for the devices of different vendors. IEEE 802.3af supports a maximum of 15.4 W power and IEEE 802.3at supports a maximum of 30 W power.

The PoE function transmits power together with data to terminals over cables or transmits power without data over idle lines. The S5700 can transmit power together with data at a rate of up to 1000 Mbit/s.

2.7.2 Panel

The S5700 supports the 250 W PoE power supply unit, as shown in [Figure 2-9](#), and 500 W PoE power supply unit, as shown in [Figure 2-10](#). The power fan appearances of the two power supply units are different.

Figure 2-9 Appearance of the 250 W AC PoE power supply unit

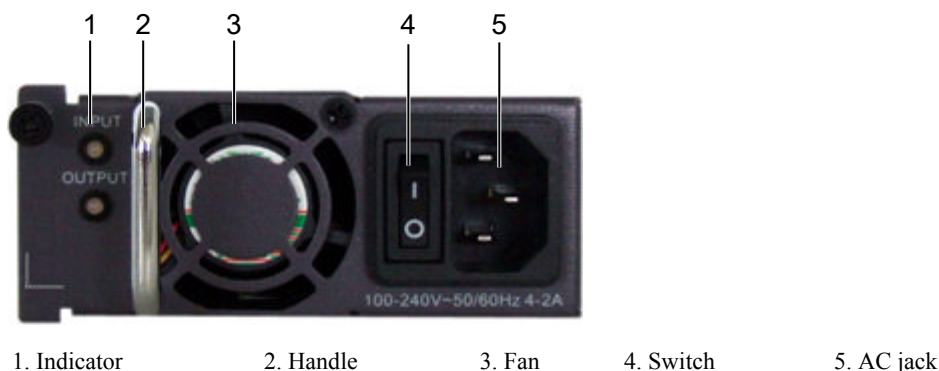
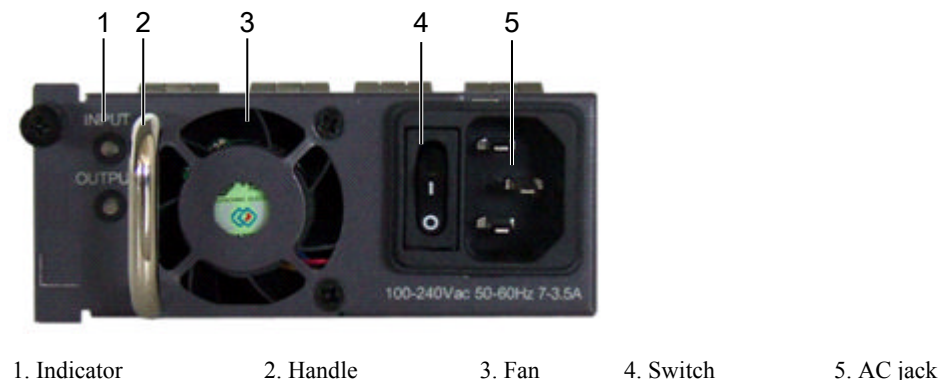

Figure 2-10 Appearance of the 500 W AC PoE power supply unit



[Table 2-9](#) describes the meanings of the indicator.

Table 2-9 Description of the AC PoE power indicators

Name	Status	Description
INPUT	Green	The input power is within range.
	Red	The input power is out of range, for example: <ul style="list-style-type: none"> ● Undervoltage ● Overvoltage
	Off	The power cable is loose or no input AC power is provided.
OUTPUT	Green	The AC output power is within range.
	Red	The output power is out of range, for example: <ul style="list-style-type: none"> ● Abnormal power fan operation ● Output overvoltage ● Output overcurrent ● Short circuit ● Overtemperature
	Off	The power cable is loose or no input AC power is provided.

2.7.3 Technical Specifications

Table 2-10 describes the technical specifications of the AC PoE power supply unit.

Table 2-10 Technical specifications of the AC PoE power supply unit

Item	250 W PoE	500 W PoE
Dimensions (width x depth x height)	100 mm x 220 mm x 43 mm	
Weight	0.8 kg	1.06 kg
Rated input voltage	100 V AC to 240 V AC, 50/60 Hz	
Maximum input voltage	90 V AC to 264 V AC, 47 Hz to 63 Hz	
Maximum input current	4 A to 2 A	7 A to 3.5 A

Item	250 W PoE	500 W PoE
Maximum output current	<ul style="list-style-type: none">● 12 V: 10 A● -53.5 V: 2.5 A	<ul style="list-style-type: none">● 12 V: 10 A● -53.5 V: 7.11 A
Maximum output power	PoE: 130 W Total: 250 W	PoE: 380 W Total: 500 W



NOTE

A PoE power supply unit provides 12 V voltage for the entire device and -53.5 V voltage for powered devices (PDs).

3 Heat Dissipation System

About This Chapter

This chapter describes the heat dissipation system of the S5700.

[3.1 Heat Dissipation Mode](#)

This section describes the heat dissipation modes of the S5700.

[3.2 Fan Module](#)

This section describes the appearance and technical specifications of the S5700 fan module.

3.1 Heat Dissipation Mode

This section describes the heat dissipation modes of the S5700.

The heat dissipation system ensures that the S5700 operates at a normal temperature. The operating temperature of the S5700 is the long-term operating temperature in [1.6 Physical Specifications](#).

The heat dissipation system can be in the following modes:

- Natural heat dissipation
- Intelligent heat dissipation
- Forcible heat dissipation

Table 3-1 provides the S5700 models corresponding to each heat dissipation mode.

Table 3-1 S5700 heat dissipation modes

Heat Dissipation Mode	Model
Natural heat dissipation	-
Intelligent heat dissipation	<ul style="list-style-type: none"> ● S5700-24TP-SI-AC ● S5700-24TP-SI-DC ● S5700-48TP-SI-AC ● S5700-48TP-SI-DC
Forcible heat dissipation	<ul style="list-style-type: none"> ● S5700-28C-EI ● S5700-28C-EI-24S ● S5700-52C-EI ● S5700-24TP-PWR-SI ● S5700-48TP-PWR-SI ● S5700-28C-PWR-EI ● S5700-52C-PWR-EI ● S5700-28C-SI ● S5700-52C-SI ● S5700-28C-HI ● S5700-28C-HI-24S ● S5700-6TP-LI-AC

 **NOTE**

The fans can work in the intelligent mode or forcible mode.

In the intelligent mode, the fans start to operate only when the ambient temperature goes higher than a specified value.

The following table describes the air circulation through the S5700 chassis.

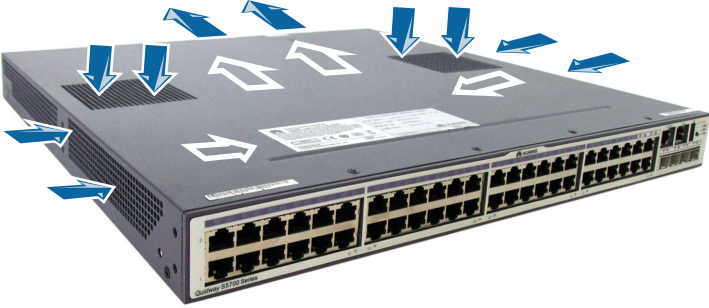
No.	Air Circulation	Model
1		<ul style="list-style-type: none"> ● S5700-28 C-EI ● S5700-28 C-EI-24S ● S5700-52 C-EI ● S5700-24 TP-PWR-SI ● S5700-48 TP-PWR-SI ● S5700-28 C-PWR-EI ● S5700-52 C-PWR-EI ● S5700-28 C-SI ● S5700-52 C-SI ● S5700-6T P-LI-AC
2		<ul style="list-style-type: none"> ● S5700-24 TP-SI-AC ● S5700-24 TP-SI-DC ● S5700-48 TP-SI-AC ● S5700-48 TP-SI-DC

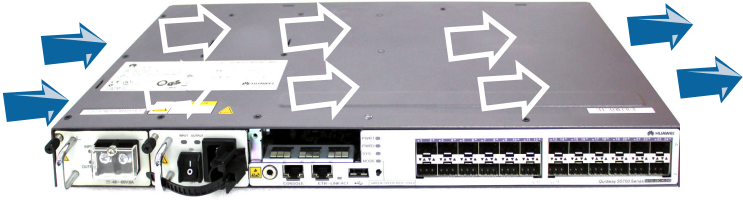
No.	Air Circulation	Model
3		<ul style="list-style-type: none"> ● S5700-28 C-HI ● S5700-28 C-HI-24S

3.2 Fan Module

This section describes the appearance and technical specifications of the S5700 fan module.

Appearance

The S5700 fan module consists of two fans. The fans can be replaced when the device is operating.

The fan module can be installed on S5700-28C-EI-24S, S5700-28C-EI, S5700-28C-SI, S5700-52C-EI, S5700-52C-SI, S5700-28C-PWR-EI, S5700-52C-PWR-EI, S5700-24TP-PWR-SI, and S5700-48TP-PWR-SI.

Figure 3-1 shows the appearance of the fan module.

Figure 3-1 Fan module appearance

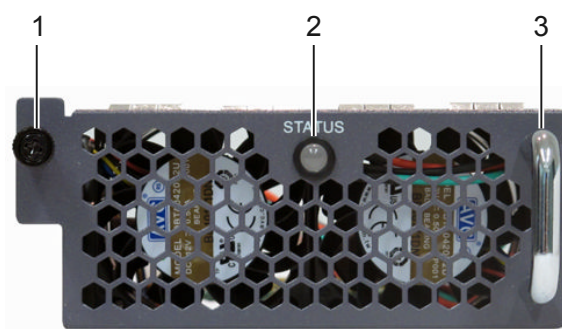

1. Captive screw

2. Indicator

3. Handle

Indicator

Table 3-2 describes the fan module indicator of the S5700.

Table 3-2 Fan indicator description

Name	Color	Description
STATUS	Blinking green (1 Hz)	The fan module is operating properly.
	Blinking red (1 Hz)	The fan module is faulty.

Technical Specifications

Table 3-3 describes the technical specifications of the S5700 fan module.

Table 3-3 Fan module technical specifications

Item	Specification
Dimensions (width x depth x height)	103.0 mm x 99.2 mm x 39.6 mm
Weight	230 g to 270 g
Maximum power consumption	12 W
Maximum wind pressure	375 Pa
Maximum wind rate	40 CFM
Maximum noise	60 dB
Operating voltage	12 V DC

4 Interface Subcards

About This Chapter

This section describes the interface subcards supported by the S5700.

[4.1 Introduction](#)

This section provides an overview of the interface subcards supported by the S5700, including interface subcard types, relationships between interface subcards, and interface numbers.

[4.2 E2XX-2-Port 10GE XFP Optical Interface Subcard](#)

This section describes the functions, appearance, indicators, interfaces, and technical specifications of the 2-port 10GE XFP optical interface subcard.

[4.3 E2XY-2-Port 10GE SFP+ Optical Interface Subcard](#)

This section describes the functions, appearance, indicators, interfaces, and technical specifications of the 2-port 10GE SFP+ optical interface subcard.

[4.4 E4GF/E4GFA-4-Port GE Optical Interface Subcard](#)

This section describes the functions, appearance, indicators, interfaces, and technical specifications of the 4-port GE SFP optical interface subcard.

[4.5 E4XY-4-Port 10GE SFP+ Optical Interface Subcard](#)

This section describes the functions, appearance, indicators, interfaces, and technical specifications of the 4-port 10GE SFP+ optical interface subcard.

[4.6 X2SA/X4SA-2/4-Port GE SFP/10G SFP+ Optical Interface Subcard](#)

This section describes the functions, appearance, indicators, interfaces, and technical specifications of the 2/4-port GE SFP/10G SFP+ optical interface subcard.

[4.7 G4SC-4-Port GE SFP Optical Interface Subcard](#)

This section describes the functions, appearance, indicators, interfaces, and technical specifications of the 4-port GE SFP optical interface subcard.

[4.8 ETPC-Stack Rear Subcard](#)

This section describes the functions, appearance, indicators, interfaces, and technical specifications of the stack subcard.

[4.9 ETPB-Extended Rear Subcard](#)

This section describes the functions, appearance, indicators, interfaces, and technical specifications of the extended rear subcard.

4.1 Introduction

This section provides an overview of the interface subcards supported by the S5700, including interface subcard types, relationships between interface subcards, and interface numbers.

4.1.1 Interface Subcard Types

Table 4-1 lists the interface subcards supported by the S5700.

Table 4-1 List of the interface cards supported by the S5700

Interface Subcard Type	Name	Supported Device Model
Front subcard	E2XX-2-port 10GE XFP optical interface subcard	<ul style="list-style-type: none"> ● S5700-28C-EI ● S5700-52C-EI ● S5700-28C-EI-24S
	E2XY-2-port 10GE SFP+ optical interface subcard	<ul style="list-style-type: none"> ● S5700-28C-SI ● S5700-52C-SI ● S5700-28C-PWR-EI ● S5700-52C-PWR-EI
	E4XY-4-port 10GE SFP+ optical interface subcard	<ul style="list-style-type: none"> ● S5700-28C-EI ● S5700-52C-EI ● S5700-28C-EI-24S ● S5700-28C-SI ● S5700-52C-SI ● S5700-28C-PWR-EI ● S5700-52C-PWR-EI
	E4GFA-4-port GE optical interface subcard	S5700SI
	E4GF-4-port GE optical interface subcard	S5700EI
	X4SA-4-port GE SFP/10G SFP+ optical interface subcard	<ul style="list-style-type: none"> ● S5700-28C-HI ● S5700-28C-HI-24S
	X2SA-2-port GE SFP/10G SFP+ optical interface subcard	

Interface Subcard Type	Name	Supported Device Model
	G4SC-4-port GE SFP optical interface subcard	
Rear subcard	ETPC-stack rear subcard	<ul style="list-style-type: none"> ● S5700EI ● S5700SI
	ETPB-extended rear subcard	<ul style="list-style-type: none"> ● S5700-28C-EI ● S5700-52C-EI ● S5700-28C-EI-24S ● S5700-28C-SI ● S5700-52C-SI ● S5700-28C-PWR-EI ● S5700-52C-PWR-EI



NOTE

Interface cards on the S5700C series except for the S5700-28C-HI and S5700-28C-HI-24S are not hot swappable.

An S5700C switch cannot be configured with both ETPB and ETPC. [Table 4-2](#) lists the restrictions on card selection.

Table 4-2 Card selection restriction

Rear Card	Front Card				
	E2XX	E2XY	E4XY	E4GFA	E4GF
ETPC	Y	Y	N	N	N
ETPB	N	N	Y	Y	Y

- Y-can be used
- N-Not recommended

4.1.2 Interface Numbering

On the S5700, interfaces are numbered in the format of slot ID/subcard ID/interface sequence number.

- Slot ID
The slot ID specifies the ID of the slot where a card resides. The S5700 supports only one card that integrates the control, switching, and service functions, so the slot ID is always 0.

- Subcard ID
The S5700 supports only one front subcard, so the subcard ID is 0 or 1.
The value 1 indicates an interface on a front subcard. The value 0 indicates an interface on the device.
- Interface sequence number
The interface sequence number indicates the number of each interface on a subcard as shown in [Table 4-3](#).

Table 4-3 Interface numbering rules

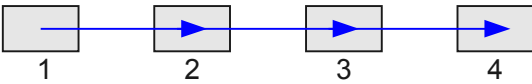
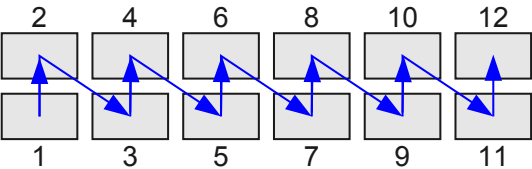
Number of Rows for Interfaces	Diagram for Interface Numbering	Description
1		There is only one row of interfaces on the interface subcard. These interfaces are numbered from left to right starting with 1.
2		There are two rows of interfaces on the interface subcard. These interfaces are numbered from bottom to top and left to right starting with 1.

If an interface does not reside on a front subcard and is the fifth interface from left to right and top to bottom, the interface is named Ethernet 0/0/5. If the stacking function is enabled and the stack ID is 1, the interface is named Ethernet 1/0/5.

If an interface resides on a front subcard and is the third interface from left to right, the interface is named Ethernet 0/1/3. If the stacking function is enabled and the stack ID is 1, the interface is named Ethernet 1/1/3.

4.2 E2XX-2-Port 10GE XFP Optical Interface Subcard

This section describes the functions, appearance, indicators, interfaces, and technical specifications of the 2-port 10GE XFP optical interface subcard.

4.2.1 Functions and Applications

Functions

The E2XX provides two 10GE XFP optical interfaces to implement data access and line-speed switching.

Applications

The E2XX can be inserted into the front subcard slot of the S5700-28C-EI, S5700-52C-EI, S5700-28C-EI-24S, S5700-28C-SI, S5700-52C-SI, S5700-28C-PWR-EI, or S5700-52C-PWR-EI.

The E2XX is not hot swappable.

The cost of a 10GE interface is higher than that of other interfaces, so it is used as an uplink aggregation interface on high-bandwidth and high-speed Metropolitan Area Networks (MANs) or backbone networks. When an enterprise user needs the high-quality triple-play service, the E2XX provides access interfaces for downlink devices or networks. The E2XX uses fibers as transmission media and supports up to 80 km transmission distance. Different transmission distances can be supported by changing XFP optical modules.

4.2.2 Panel

Figure 4-1 shows the appearance of the E2XX.

Figure 4-1 Appearance of the E2XX



Table 4-4 describes the meanings of indicators on the E2XX.

Table 4-4 Description of indicators on the E2XX

Indicator	Color	Description
ACT/LNK	Green-yellow	If the indicator is blinking, data is being transmitted or received.
		If the indicator is steady on, a link has been connected.

4.2.3 Interfaces

Table 4-5 describes the types and functions of interfaces on the E2XX.

Table 4-5 Types and functions of interfaces on the E2XX

Type	Quantity	Description
10G BASE-SR/LR optical interface	2	The E2XX provides two 10 Gbit/s optical interfaces to transmit and receive Ethernet services at 10 Gbit/s.

4.2.4 Interface Attributes

Table 4-6 describes the attributes of 10GE optical interfaces.

Table 4-6 Attributes of 10GE optical interfaces (10G Base-X)

Attribute	Description
Connector type	LC/PC
Optical interface attribute	Depending on the XFP optical module (for details, see section 7.4 XFP Optical Module (10GE) Attributes)
Standards compliance	IEEE 802.3ae
Frame format	Ethernet_II, Ethernet_SAP, or Ethernet_SNAP
Network layer protocol	IP

4.2.5 Technical Specifications

Table 4-7 describes the technical specifications of the E2XX.

Table 4-7 Technical specifications of the E2XX

Parameter	Description
Dimensions	200.0 mm x 69.0 mm x 22.0 mm (width x depth x height)
Power consumption	11 W
Weight	0.2 kg

4.3 E2XY-2-Port 10GE SFP+ Optical Interface Subcard

This section describes the functions, appearance, indicators, interfaces, and technical specifications of the 2-port 10GE SFP+ optical interface subcard.

4.3.1 Functions and Applications

Functions

The E2XY provides two 10GE SFP+ optical interfaces to implement data access and line-speed switching.



NOTE

The two optical interfaces of the E2XY support only the 10G SFP+ optical modules.

Applications

The E2XY can be inserted into the front subcard slot of the S5700-28C-EI, S5700-52C-EI, S5700-28C-EI-24S, S5700-28C-SI, S5700-52C-SI, S5700-28C-PWR-EI, or S5700-52C-PWR-EI.

The E2XY is not hot swappable.

The cost of a 10GE interface is higher than that of other interfaces, so it is used as an uplink aggregation interface on high-bandwidth and high-speed Metropolitan Area Networks (MANs) or backbone networks. When an enterprise user needs the high-quality triple-play service, the E2XY provides access interfaces for downlink devices or networks. The E2XY uses fibers as transmission media and supports up to 40 km transmission distance. Different transmission distances can be supported by changing SFP+ optical modules.

4.3.2 Panel

Figure 4-2 shows the appearance of the E2XY.

Figure 4-2 Appearance of the E2XY



Table 4-8 describes the meanings of indicators on the E2XY.

Table 4-8 Description of indicators on the E2XY

Indicator	Color	Description
ACT/LNK	Green-yellow	If the indicator is blinking, data is being transmitted or received.
		If the indicator is steady on, a link has been connected.

4.3.3 Interfaces

Table 4-9 describes the types and functions of interfaces on the E2XY.

Table 4-9 Types and functions of interfaces on the E2XY

Type	Quantity	Description
10G BASE-ER/SR/LR/LRM optical interface	2	The E2XY provides two 10 Gbit/s optical interfaces to transmit and receive Ethernet services at 10 Gbit/s.

4.3.4 Interface Attributes

Table 4-10 describes the attributes of 10GE optical interfaces.

Table 4-10 Attributes of 10GE optical interfaces (10G Base-X)

Attribute	Description
Connector type	LC/PC
Optical interface attribute	Depending on the SFP+ optical module (for details, see section 7.5 SFP + Optical Module (10GE) Attributes)
Standards compliance	IEEE 802.3ae
Frame format	Ethernet_II, Ethernet_SAP, or Ethernet_SNAP
Network layer protocol	IP

4.3.5 Technical Specifications

Table 4-11 describes the technical specifications of the E2XY.

Table 4-11 Technical specifications of the E2XY

Parameter	Description
Dimensions	200.0 mm x 69.0 mm x 22.0 mm (width x depth x height)
Power consumption	6.5 W
Weight	0.2 kg

4.4 E4GF/E4GFA-4-Port GE Optical Interface Subcard

This section describes the functions, appearance, indicators, interfaces, and technical specifications of the 4-port GE SFP optical interface subcard.

4.4.1 Functions and Applications

Functions

The E4GF/E4GFA provides four GE SFP optical interfaces to implement data access and line-speed switching.

Applications



CAUTION

The E4GF cannot work on the S5700SI and the E4GFA cannot work on the S5700EI.

The E4GF/E4GFA front subcard should be used together with the ETPB extended rear subcard; otherwise, only two interfaces of the front subcard can work.

The E4GF can be inserted into the front subcard slot of the S5700-28C-EI, S5700-52C-EI, S5700-28C-EI-24S, S5700-28C-PWR-EI, or S5700-52C-PWR-EI.

The E4GFA can be inserted into the front subcard slot of the S5700-28C-SI, or S5700-52C-SI.

The E4GF or E4GFA is not hot swappable.

The cost of a GE interface is higher than that of other interfaces, so it is used as an uplink aggregation interface on high-bandwidth and high-speed Metropolitan Area Networks (MANs) or backbone networks. When an enterprise user needs the high-quality triple-play service, the E4GF/E4GFA provides access interfaces for downlink devices or networks. The E4GF/E4GFA uses fibers as transmission media and supports up to 100 km transmission distance. Different transmission distances can be supported by changing ESFP optical modules.

4.4.2 Panel

Figure 4-3 shows the appearance of the E4GF (applicable to the S5700EI).

Figure 4-3 Appearance of the E4GF

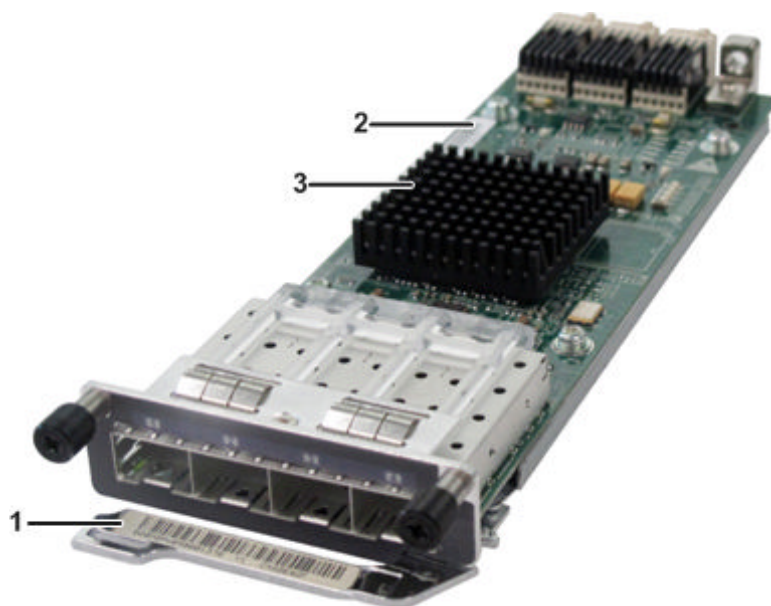
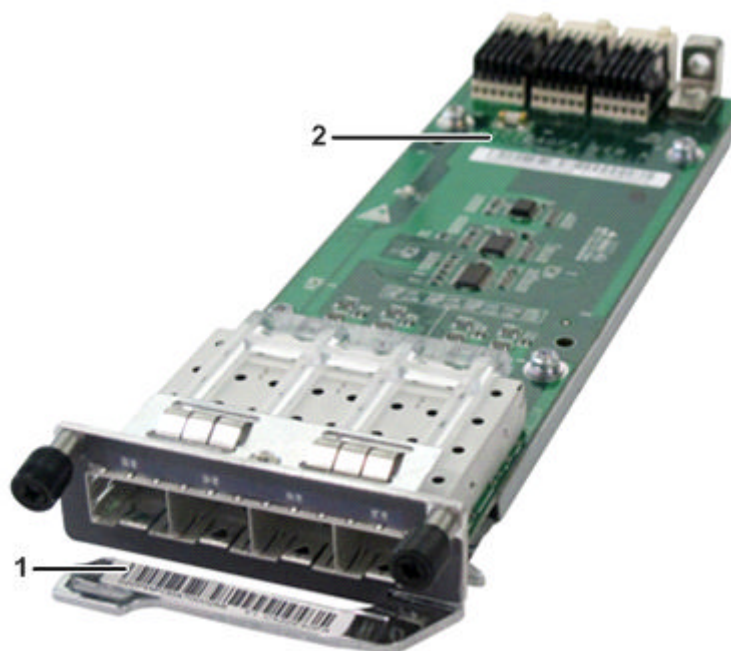

Figure 4-4 shows the appearance of the E4GFA (applicable to the S5700SI).

Figure 4-4 Appearance of the E4GFA



1. Front panel label

2. Silkscreen and card label

3. Cooling fin

Differences between the E4GF and E4GFA are as follows:

- The labels on the front panels are different. The front panel label of the E4GF is CX22E4GF, and the front panel label of the E4GFA is CX22E4GFA.
- The silkscreens and bar codes on the front cards are different, as shown in Figure 4-3 and Figure 4-4. The silkscreens show the card types and versions. The silkscreen of the E4GF

is CX22E4GF VER.A, and the silkscreen of the E4GFA is CX22E4GFA VER.A. The card labels show the card types. The label of the E4GF is CX22E4GF, and the label of the E4GFA is CX22E4GFA.

- The card appearances are different. The E4GF has the cooling fins, as shown in [Figure 4-3](#), whereas the E4GFA does not, as shown in [Figure 4-4](#).

[Table 4-12](#) describes the meanings of indicators on the E4GF/E4GFA.

Table 4-12 Description of indicators on the E4GF/E4GFA

Indicator	Color	Description
ACT/LNK	Green-yellow	If the indicator is blinking, data is being transmitted or received.
		If the indicator is steady on, a link has been connected.

4.4.3 Interfaces

[Table 4-13](#) describes the types and functions of interfaces on the E4GF/E4GFA.

Table 4-13 Types and functions of interfaces on the E4GF/E4GFA

Type	Quantity	Description
1000M BASE-X optical interface	4	The E4GF or E4GFA provides four 1000 Mbit/s optical interfaces to transmit and receive Ethernet services at 1000 Mbit/s.

4.4.4 Interface Attributes

[Table 4-14](#) describes the optical interface attributes.

Table 4-14 Attributes of GE optical interfaces (1000M Base-X)

Attribute	Description
Connector type	LC/PC
Optical interface attribute	Depending on the optical module (for details, see section 7.2 ESFP Optical Module (GE) Attributes and section 7.3 ESFP CWDM-SFP Optical Module)
Standards compliance	IEEE 802.3Z
Frame format	Ethernet_II, Ethernet_SAP, or Ethernet_SNAP

Attribute	Description
Network layer protocol	IP

4.4.5 Technical Specifications

Table 4-15 describes the technical specifications of the E4GF/E4GFA.

Table 4-15 Technical specifications of the E4GF/E4GFA

Parameter	Description
Dimensions	200.0 mm x 69.0 mm x 22.0 mm (width x depth x height)
Power consumption	6 W for the E4GF 4.5 W for the E4GFA
Weight	0.2 kg

4.5 E4XY-4-Port 10GE SFP+ Optical Interface Subcard

This section describes the functions, appearance, indicators, interfaces, and technical specifications of the 4-port 10GE SFP+ optical interface subcard.

4.5.1 Functions and Applications

Functions

The E4XY provides four 10GE SFP+ optical interfaces to implement data access and line-speed switching.

 **NOTE**

The four optical interfaces provided by the E4XY support only the 10G SFP+ optical modules.

Applications

The E4XY can be inserted into the front subcard slot of the S5700-28C-SI, S5700-52C-SI, S5700-28C-EI, S5700-52C-EI, S5700-28C-PWR-EI, S5700-52C-PWR-EI or S5700-28C-EI-24S.

The E4XY is not hot swappable.

The cost of a 10GE interface is higher than that of other interfaces, so it is used as an uplink aggregation interface on high-bandwidth and high-speed Metropolitan Area Networks (MANs) or backbone networks. When an enterprise user needs the high-quality triple-play service, the E4XY provides access interfaces for downlink devices or networks. The E4XY uses fibers as

transmission media and supports up to 40 km transmission distance. Different transmission distances can be supported by changing SFP+ optical modules.



CAUTION

The E4XY front subcard should be used together with the ETPB extended rear subcard; otherwise, only two interfaces of the front subcard can work.

4.5.2 Panel

Figure 4-5 shows the appearance of the E4XY.

Figure 4-5 Appearance of the E4XY



Table 4-16 describes the meanings of indicators on the E4XY.

Table 4-16 Description of indicators on the E4XY

Indicator	Color	Description
ACT/LNK	Green-yellow	If the indicator is blinking, data is being transmitted or received.
		If the indicator is steady on, a link has been connected.

4.5.3 Interfaces

Table 4-17 describes the types and functions of interfaces on the E4XY.

Table 4-17 Types and functions of interfaces on the E4XY

Type	Quantity	Description
10G BASE-ER/SR/LR/LRM optical interface	4	The E4XY provides four 10 Gbit/s optical interfaces to transmit and receive Ethernet services at 10 Gbit/s.

4.5.4 Interface Attributes

Table 4-18 describes the attributes of 10GE optical interfaces.

Table 4-18 Attributes of 10GE optical interfaces (10G Base-X)

Attribute	Description
Connector type	LC/PC
Optical interface attribute	Depending on the SFP+ optical module (for details, see section 7.5 SFP+ Optical Module (10GE) Attributes)
Standards compliance	IEEE 802.3ae
Frame format	Ethernet_II, Ethernet_SAP, or Ethernet_SNAP
Network layer protocol	IP

4.5.5 Technical Specifications

Table 4-19 describes the technical specifications of the E4XY.

Table 4-19 Technical specifications of the E4XY

Parameter	Description
Dimensions	200.0 mm x 69.0 mm x 22.0 mm (width x depth x height)
Power consumption	13 W
Weight	0.3 kg

4.6 X2SA/X4SA-2/4-Port GE SFP/10G SFP+ Optical Interface Subcard

This section describes the functions, appearance, indicators, interfaces, and technical specifications of the 2/4-port GE SFP/10G SFP+ optical interface subcard.

4.6.1 Functions and Applications

Functions

The X2SA/X4SA provides two/four 10G SFP+ optical interfaces to implement data access and line-speed switching.

The S5700HI SCU powers on or off the X2SA/X4SA, and detects whether the X2SA/X4SA is installed or not, and manages PHY chips and optical interfaces on the X2SA/X4SA. The X2SA/X4SA works with the entire system to provide enhanced service features such as OAM and BFD.



NOTE

The X2SA/X4SA provides two/four optical interfaces, which can be connected to 10G SFP+ or 1000M SFP optical modules.

Applications

The X2SA/X4SA can be inserted into the front subcard slot of the S5700HI and is hot swappable.

4.6.2 Panel

Figure 4-6 shows the appearance of the X2SA.

Figure 4-6 Appearance of the X2SA



Figure 4-7 shows the appearance of the X4SA.

Figure 4-7 Appearance of the X4SA

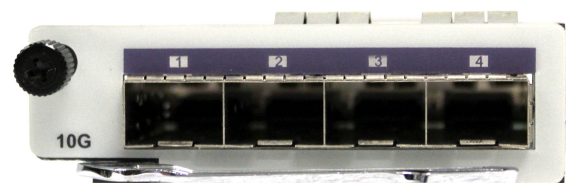

Table 4-20 describes the meanings of indicators on the X2SA/X4SA.

Table 4-20 Description of indicators on the X2SA/X4SA

Indicator	Color	Description
ACT/LINK	Green-yellow	If the indicator is blinking, data is being transmitted or received.
		If the indicator is steady on, a link has been connected.

4.6.3 Interfaces

Table 4-21 describes the types and functions of interfaces on the X2SA/X4SA.

Table 4-21 Types and functions of interfaces on the X2SA/X4SA

Type	Quantity	Description
10G BASE-SR/LR/LRM/ER optical interface (X2SA)	2	The X2SA provides two 10 Gbit/s optical interfaces to transmit and receive Ethernet services at 10 Gbit/s.
10G BASE-SR/LR/LRM/ER optical interface (X4SA)	4	The X4SA provides four 10 Gbit/s optical interfaces to transmit and receive Ethernet services at 10 Gbit/s.



NOTE

The X2SA/X4SA provides two/four optical interfaces, which can be connected to 10G SFP+ or 1000M SFP optical modules.

4.6.4 Interface Attributes

Table 4-22 describes the attributes of optical interfaces on the X2SA/X4SA.

Table 4-22 Attributes of interfaces on the X2SA/X4SA

Attribute	Description
Connector type	LC/PC
Optical interface attribute	Depending on the optical module (for details, see section 7.5 SFP+ Optical Module (10GE) Attributes and section 7.2 ESFP Optical Module (GE) Attributes)
Standards compliance	IEEE 802.3ae
Frame format	Ethernet_II, Ethernet_SAP, or Ethernet_SNAP
Network layer protocol	IP

4.6.5 Technical Specifications

Table 4-23 describes the technical specifications of the X2SA/X4SA.

Table 4-23 Technical specifications of the X2SA/X4SA

Parameter	Description
Dimensions	200.0 mm x 77.0 mm x 23.0 mm (width x depth x height)
Power consumption	7 W for the X2SA 10 W for the X4SA

Parameter	Description
Weight	0.5 kg

4.7 G4SC-4-Port GE SFP Optical Interface Subcard

This section describes the functions, appearance, indicators, interfaces, and technical specifications of the 4-port GE SFP optical interface subcard.

4.7.1 Functions and Applications

Functions

The G4SC provides four 1000M SFP optical interfaces to implement data access and line-speed switching.

The S5700HI SCU powers on or off the G4SC, detects whether the G4SC is installed or not, and optical interfaces on the G4SC. The G4SC works with the entire system to provide enhanced service features such as OAM and BFD.

Applications

The G4SC can be inserted into the front subcard slot of the S5700HI and is hot swappable.

4.7.2 Panel

Figure 4-8 shows the appearance of the G4SC.

Figure 4-8 Appearance of the G4SC

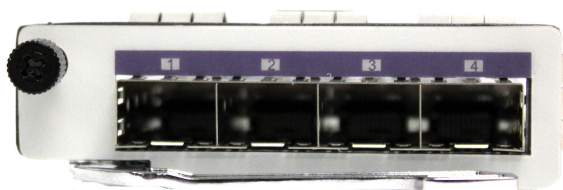

Table 4-24 describes the meanings of indicators on the G4SC.

Table 4-24 Description of indicators on the G4SC

Indicator	Color	Description
ACT/LINK	Green-yellow	If the indicator is blinking, data is being transmitted or received.
		If the indicator is steady on, a link has been connected.

4.7.3 Interfaces

Table 4-25 describes the types and functions of interfaces on the G4SC.

Table 4-25 Types and functions of interfaces on the G4SC

Type	Quantity	Description
1000M BASE-X optical interface	4	The G4SC provides four 1000 Mbit/s optical interfaces to transmit and receive services at 1000 Mbit/s.

4.7.4 Interface Attributes

Table 4-26 describes the optical interface attributes.

Table 4-26 Attributes of GE optical interfaces (1000M Base-X)

Attribute	Description
Connector type	LC/PC
Optical interface attribute	Depending on the optical module (for details, see section 7.2 ESFP Optical Module (GE) Attributes and section 7.3 ESFP CWDM-SFP Optical Module)
Standards compliance	IEEE 802.3Z
Frame format	Ethernet_II, Ethernet_SAP, or Ethernet_SNAP
Network layer protocol	IP

4.7.5 Technical Specifications

Table 4-27 lists the technical specifications of the G4SC.

Table 4-27 Technical specifications of the G4SC

Parameter	Description
Dimensions	200.0 mm x 77.0 mm x 23.0 mm (width x depth x height)
Power consumption	4 W
Weight	0.3 kg

4.8 ETPC-Stack Rear Subcard

This section describes the functions, appearance, indicators, interfaces, and technical specifications of the stack subcard.

4.8.1 Functions and Applications

Functions

The ETPC provides two 12 Gbit/s electrical interfaces to implement data access and line-speed switching.

Stacking is a technology that connects multiple switches by using the ETPC to function as a logical device. The S5700 supports a maximum of nine switches in a stack system.

Applications

The ETPC can be inserted into the S5700-24TP-SI-AC, S5700-24TP-SI-DC, S5700-48TP-SI-AC, S5700-48TP-SI-DC, S5700-28C-EI, S5700-52C-EI, S5700-28C-EI-24S, S5700-28C-SI, S5700-52C-SI, S5700-24TP-PWR-SI, S5700-48TP-PWR-SI, S5700-28C-PWR-EI, or S5700-52C-PWR-EI for stacking.



CAUTION

The following requirements must be met to implement stacking:

- All the member switches belong to the same series. The EI series and SI series cannot form a stack.
 - All the member switches are connected by using stack cables and stack modules.
 - The stack rear subcard cannot be used together with the E4GF/E4GFA or E4XY front subcard.
-

4.8.2 Appearance

Figure 4-9 shows the appearance of the ETPC.

Figure 4-9 Appearance of the ETPC



4.8.3 Interfaces

Table 4-28 describes the types and functions of interfaces on the ETPC.

Table 4-28 Types and functions of interfaces on the ETPC

Type	Quantity	Description
PCI-E electrical interface	2	The ETPC provides two 12 Gbit/s electrical interfaces to transmit and receive services.

4.8.4 Technical Specifications

Table 4-29 describes the technical specifications of the ETPC.

Table 4-29 Technical specifications of the ETPC

Parameter	Description
Dimensions	200.0 mm x 69.0 mm x 22.0 mm (width x depth x height)
Power consumption	0.5 W
Weight	0.2 kg

4.9 ETPB-Extended Rear Subcard

This section describes the functions, appearance, indicators, interfaces, and technical specifications of the extended rear subcard.

4.9.1 Functions and Applications

Functions

The ETPB extended rear subcard must be used together with the E4GF/E4GFA or E4XY front subcard to provide four SFP GE interfaces or SFP+ 10GE interfaces.

Applications

The ETPB can be inserted into the S5700-28C-EI, S5700-52C-EI, S5700-28C-EI-24S, S5700-28C-SI, S5700-52C-SI, S5700-28C-PWR-EI, or S5700-52C-PWR-EI for interface extension.



CAUTION

The E4GF/E4GFA or E4XY front subcard must be used together with the ETPB extended rear subcard.

4.9.2 Appearance

Figure 4-10 shows the appearance of the ETPB.

Figure 4-10 Appearance of the ETPB



4.9.3 Technical Specifications

Table 4-30 describes the technical specifications of the ETPB.

Table 4-30 Technical specifications of the ETPB

Parameter	Description
Dimensions	200.0 mm x 69.0 mm x 22.0 mm (width x depth x height)
Power consumption	0.1 W
Weight	0.2 kg

5 Cables

About This Chapter

5.1 DC Power Cables

A DC power cable transmits DC power to the switch.

5.2 AC Power Cables

An AC power cable transmits AC power to the switch.

5.3 Ground Cables

A ground cable protects the device from lightning strike and electromagnetic interference.

5.4 Console Cables

A console cable is used to debug or maintain a local S5700.

5.5 Network Cables

A network cable subtends devices, enables a device to communication with other network devices, and allows users to locally or remotely maintain the device.

5.6 Optical Fibers

An optical fiber connects the optical interface of a device to an upstream device or optical network terminal.

5.7 Stack cables

This section describes the structure and technical specifications of a stack cable.

5.1 DC Power Cables

A DC power cable transmits DC power to the switch.

Applications

A DC power cable connects the following two interfaces:

- Input power jack on the chassis
- Output power interface on an external power system

 **NOTE**

A black -48 V DC power return wire (RTN) is connected to the RTN(+) end of the DC power supply. A blue -48 V DC power cable is connected to the NEG(-) end of the DC power supply.

Appearance and Structure

The black -48 V DC power return wire and the blue -48 V DC power cable are shown in [Figure 5-1](#) and [Figure 5-2](#).

Figure 5-1 -48 V DC power return wire



Figure 5-2 -48 V DC power cable



Specifications

The technical specifications of a -48 V DC power return wire and a -48 V DC power cable are the same, as described in [Table 5-1](#).

Table 5-1 Specifications of the DC power cables

Item	Description
Cable type	Power cable
Color	Blue for -48 V DC power cable and black for -48 V DC power return wire
Connector 1	OT
Connector 2	Cord end terminal
Impedance	4.95 Ω /km
Conductor cross-sectional area	1.2 mm ²

5.2 AC Power Cables

An AC power cable transmits AC power to the switch.

Applications

An AC power cable connects the following:

- AC input power jack on the chassis
- Mains supply

Appearance

Figure 5-3 shows the appearance of an AC power cable.

Figure 5-3 Appearance of an AC power cable



Specifications

NOTE

The AC power cables used in different countries and regions may have different specifications. The following are the specifications of the international standard AC power cable.

Table 5-2 lists the specifications of an AC power cable.

Table 5-2 Specifications of an AC power cable

Item	Description
Cable type	External power cable
Function	250 V AC/10 A complying with international standard
Connector 1	PI-straight-male
Connector 2	C13-straight-female

Item	Description
Cable type	<ul style="list-style-type: none"> ● 227 IEC 53 (RVV)-300 V/500 V ● Rated voltage: 300 V/500 V ● Standards compliance: 227 IEC 53 (RVV)
Conductor cross-sectional area	3 x 1.0 mm ²
Fireproof level	GB18380.1

5.3 Ground Cables

A ground cable protects the device from lightning strike and electromagnetic interference.

Applications

A ground cable connects the chassis to the ground.

Appearance

[Figure 5-4](#) shows the appearance of a ground cable.

Figure 5-4 Appearance of a ground cable



Specifications

[Table 5-3](#) lists the specifications of a ground cable.

Table 5-3 Specifications of a ground cable

Item	Description
Cable type	Power cable

Item	Description
Color	Green-yellow
Connector type (X1/X2)	OT/OT naked crimping terminal
Gauge	10 AWG (cross-sectional area $\approx 5.2 \text{ mm}^2$)
Cable type	<ul style="list-style-type: none"> Standards compliance: UL1015 Length: 0.3 m
Maximum current	50.0 A
Fireproof level	VW-1, CSA FT1

5.4 Console Cables

A console cable is used to debug or maintain a local S5700.

Applications

A console cable connects the console port of the S5700 to the serial port of an operation terminal to transmit configuration data. A shielded cable or an unshielded cable can be used according to the onsite situation.

A console cable connects the S5700 and terminal as follows:

- The 8-pin RJ45 connector is inserted into the S5700 console port.
- The DB9 connector is inserted into the terminal serial port.

Appearance and Structure

Figure 5-5 shows the structure of a console cable.

Figure 5-5 Structure of a console cable

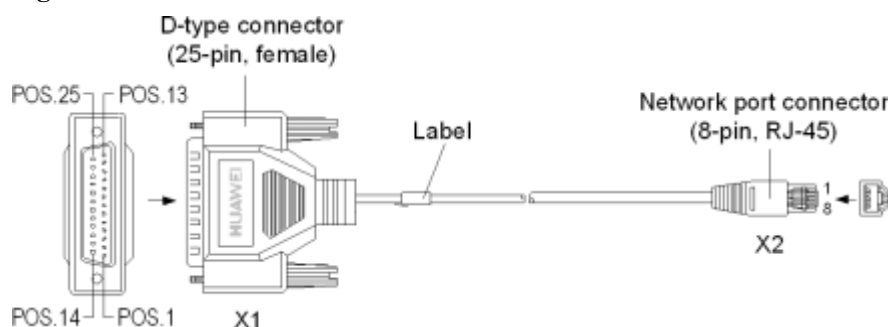

Pin Assignments

Table 5-4 describes the pin assignments of a console cable.

Table 5-4 Pin assignments of a console cable

Connector	X2 (RJ45)	Direction	X1 (DB9)	Signal
Pin assignment	1	--->	8	Clear to Send (CTS)
	2	--->	6	Data Set Ready (DSR)
	3	--->	2	Receive Data (RXD)
	4	—	5	GND
	5	—	5	GND
	6	<---	3	Transmit Data (TXD)
	7	<---	4	Data Terminal Ready (DTR)
	8	<---	7	Request to Send (RTS)

Specifications

Table 5-5 lists the specifications of a console cable.

Table 5-5 Specifications of a console cable

Item	Description
Connector type	<ul style="list-style-type: none"> ● Connector X1: cable connector, D-type, 9-pin, male ● Connector X2: network interface connector, RJ45, 8-pin, 8-bit
Cable type	Twisted pair
Color	White
Diameter	0.38 mm
Gauge	28 AWG (cross-sectional area $\approx 0.08 \text{ mm}^2$)
Pin	8-pin
Fireproof level	CM

5.5 Network Cables

A network cable subtends devices, enables a device to communication with other network devices, and allows users to locally or remotely maintain the device.

Applications

A network cable connects a maintenance terminal to the console port on the main control board for local or remote maintenance.

The network cables are classified into straight through cables and crossover cables.

- A straight through cable connects a terminal, such as a computer or switch, to the network. The straight through cable uses two RJ45 connectors, which have the same pinout.
- A crossover cable connects two terminals, such as computers or switches. The crossover cable uses two RJ45 connectors, which have difference pinouts.

Appearance and Structure

NOTE

- Generally, a network cable is a standard unshielded network cable that uses RJ45 connectors.
- The appearances of the straight through cable and the crossover cable are the same.

Figure 5-6 shows the appearance of a network cable.

Figure 5-6 Appearance of a network cable



Figure 5-7 shows the appearance of a network cable.

Figure 5-7 Structure of a network cable

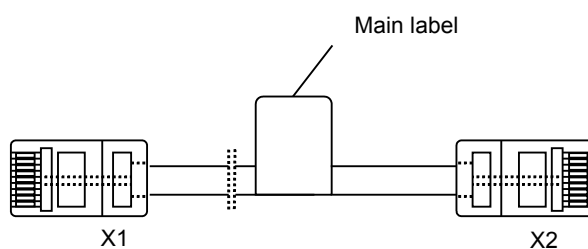

Pin Assignments

Table 5-6 describes the pin assignments of a straight through cable.

Table 5-6 Pin assignments of a straight through cable

X1 Pin	Tip Color	X2 Pin
1	White and orange	1
2	Orange	2
3	White and Green	3
4	Blue	4
5	White and Blue	5
6	Green	6
7	White and brown	7
8	Brown	8

Table 5-7 describes the pin assignments of a crossover cable.

Table 5-7 Pin assignments of a crossover cable

X1 Pin	Tip Color	X2 Pin
1	White and orange	3
2	Orange	6
3	White and Green	1
4	Blue	4
5	White and Blue	5
6	Green	2
7	White and brown	7
8	Brown	8

 **NOTE**

To achieve the optimum electrical transmission performance, ensure that the wires connected to pins 1 and 2 and to pins 3 and 6 are twisted pairs.

Specifications

Table 5-8 lists the specifications of a network cable.

Table 5-8 Specifications of a network cable

Item	Description
Connector type (X1/X2)	RJ45 connectors
Cable type	Category-3 and category-5 unshielded twisted pairs (UTP-3 and UTP-5) or shielded twisted pairs (STP)
Color	Dark gray
Characteristic impedance	100.0 Ω
Diameter	0.510 mm
Breakdown voltage	500.0 V
Impedance	93.8 Ω
Pin	8 pins
Frequency	0 MHz to 100 MHz
Frequency attenuation	22 dB/100 m@100 MHz
Fireproof level	CM
Length	<ul style="list-style-type: none"> ● Straight through cable: 5 m, 10 m, 20 m, and 30 m ● Crossover cable: 5 m and 30 m

5.6 Optical Fibers

An optical fiber connects the optical interface of a device to an upstream device or optical network terminal.

Applications

An optical fiber carries optical signals and transmits them over short distance. An optical fiber connects the following:

- Optical interface on a board
- Optical distribution frame (ODF) or the optical interface on another device

Table 5-9 lists the classification of optical fibers.

Table 5-9 Optical fiber classification

No.	Purpose	Local End Connector	Remote End Connector	Mode
1	To connect LPU of the device to the ODF	LC/PC	FC/PC	Single mode, indoor
2	To connect LPUs of two devices	LC/PC	LC/PC	Single mode/multimode, indoor
3	To connect LPU of the device to another device	LC/PC	SC/PC or LC/PC	Single mode/multimode, indoor

Appearance

The appearances of the single-mode optical fiber and the multimode optical fiber are the same, but their colors are different. The single-mode optical fiber is yellow, and the multi-mode optical fiber is orange.



CAUTION

When connecting or removing the LC/PC optical connector, align the connector with the optical interface, and do not rotate the fiber. Pay attention to the following points:

- Align the head of the fiber jumper with the optical interface and insert the optical fiber into the interface gently.
 - To remove the fiber, press the latch on the connector and pull the fiber out.
-

Figure 5-8 and **Figure 5-9** show the appearances of a single mode fiber.

Figure 5-8 Single mode fiber with LC/PC connectors

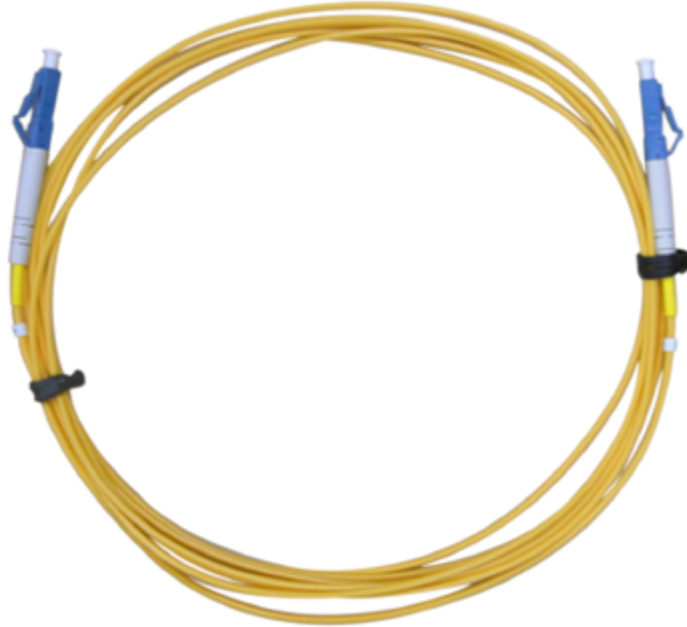

Figure 5-9 Single mode fiber with SC/PC connectors



Figure 5-10 shows the appearance of a multimode fiber.

Figure 5-10 Multimode fiber with LC/PC connectors



Pin Assignments

Table 5-10 describes the pin assignments of an optical fiber.

Table 5-10 Pin assignments of an optical fiber

Local End Terminal	Signal Direction	Remote End Terminal
Optical interface Tx terminal	->	Optical interface Rx terminal
Optical interface Rx terminal	<-	Optical interface Tx terminal

Fiber Selection Criterion

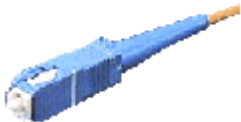



Table 5-11 lists the criteria for selecting optical fibers. **Table 5-12** lists common optical connectors.

Table 5-11 Fiber selection criterion

Parameter	Criterion
Length	Survey result

Parameter	Criterion
Single mode or multimode	<p>Optical module type</p> <ul style="list-style-type: none"> ● The optical transmitting module of the multimode mode is connected to the multimode fiber. ● The optical transmitting module of the single-longitudinal mode or multi-longitudinal mode is connected to the single mode fiber. <p>NOTE If the optical fiber jumper is used, the connector connected to the device must be the LC/PC connector, and the connector connected to the remote end must be of the same type as the remote end interface.</p>
Connector shape	<ul style="list-style-type: none"> ● Cube: SC/PC, LC/PC, and MTRJ/PC ● Column: ST/PC and FC/PC

Table 5-12 Common optical connectors

 SC/PC optical connector	 LC/PC optical connector
 FC/PC optical connector	 MTRJ/PC optical connector
 ST/PC optical connector	-

5.7 Stack cables

This section describes the structure and technical specifications of a stack cable.

Applications

A stack cable of the S5700 is the PCI-E stack cable, which interconnects the stack interfaces on the ETPC card. The S5700s connected with a stack cable form a logical switch to forward packets.

 **NOTE**

The two ends of a stack cable are covered by the ESD-preventive caps.

Appearance and Structure

Figure 5-11 shows the structure of a stack cable.

Figure 5-11 Structure of a PCI-E cable



Specifications

Table 5-13 lists the specifications of a stack cable.

Table 5-13 Specifications of a PCI-E cable

Item	Description
Cable type	100 cm PCI-E cable
Connector type	PCI-E
Standards compliance	PCI-E 8X
Length	1.0 m

6 List of Indicators

About This Chapter

This chapter describes the status and meanings of the indicators on the S5700, including the indicators for subcards, fan module, and power supply units.

[6.1 Indicators on the Front Panel](#)

This section describes the indicators on the S5700 front panel.

[6.2 Fan Indicators](#)

This section describes the fan indicators.

[6.3 Power Indicators](#)

This section describes the power indicators.

6.1 Indicators on the Front Panel

This section describes the indicators on the S5700 front panel.

Indicators of a Non-PoE S5700

S5700-24TP-SI-AC, S5700-24TP-SI-DC, S5700-48TP-SI-AC, S5700-48TP-SI-DC and S5700-6TP-LI-AC are non-PoE switches, and each of them has a single power supply unit.

 **NOTE**

Only S5700-24TP-SI-AC, S5700-24TP-SI-DC, S5700-48TP-SI-AC and S5700-48TP-SI-DC have redundancy power supply (RPS) indicators.

Figure 6-1 S5700-24TP-SI-AC indicators

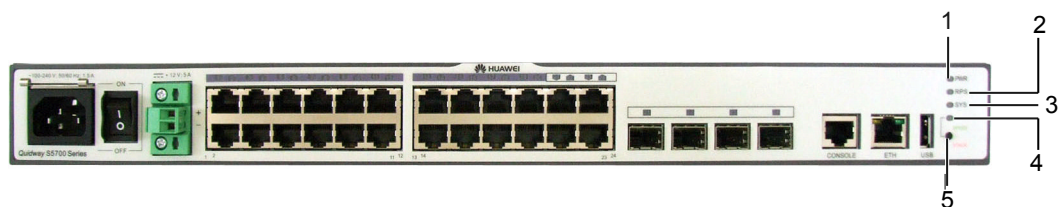

Table 6-1 Description of S5700-24TP-SI-AC indicators

No.	Indicator	Identifier	Status	Description
1	Power indicator	PWR	Off	The switch is powered off.
			Green	The switch is powered on.
			Orange	The power supply unit is faulty, and the external RPS system is started.
2	RPS indicator	RPS	Off	The RPS is not connected to the switch or the RPS is faulty.
			Green	The RPS is connected to the switch.
3	System status indicator	SYS	Off	The system is not operating.
			Green	The system is not operating properly or is starting.

No.	Indicator	Identifier	Status	Description
			Orange	The system is performing self-check during startup.
			Blinking green	The system is operating properly.
			Red	After registering, the system does not operate properly, or a power alarm, fan alarm, or temperature alarm is generated.
4	Mode indicator	-	Off	The service interface indicator is in the default mode (STAT).
			Green	The service interface indicator indicates the interface speed. After 45 seconds, the service interface indicator automatically restores to off.
			Red	The service interface indicator indicates the stack ID. After 45 seconds, the service interface indicator automatically restores to off.

Figure 6-2 S5700-6TP-LI-AC indicators

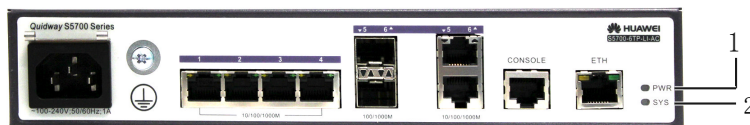

Table 6-2 Description of S5700-6TP-LI-AC indicators

No.	Indicator	Identifier	Status	Description
1	Power indicator	PWR	Off	The switch is powered off.
			Green	The switch is powered on.

No.	Indicator	Identifier	Status	Description
2	System status indicator	RUN	Off	The system is not operating.
			Green	The system is not operating properly or is starting.
			Orange	The system is performing self-check during startup.
			Blinking green	The system is operating properly.
			Red	After registering, the system does not operate properly, or a power alarm, fan alarm, or temperature alarm is generated.

S5700-28C-EI is a non-PoE switch that has two power supply units.

Figure 6-3 S5700-28C-EI indicators



Table 6-3 Description of S5700-28C-EI indicators

No.	Indicator	Identifier	Status	Description
1	Power indicator	PWR1	Off	The power supply units are not present, or the power supply is abnormal when a single power supply unit is used.
			Green	The power supply is normal.

No.	Indicator	Identifier	Status	Description
			Red	<ul style="list-style-type: none"> ● Two power supply units are installed properly, but not switched on. ● The power supply units are switched off. ● The power supply units are faulty.
2	Power indicator	PWR2	Off	The power supply units are not present, or the power supply is abnormal when a single power supply unit is used.
			Green	The power supply is normal.
			Red	<ul style="list-style-type: none"> ● Two power supply units are installed properly, but not switched on. ● The power supply units are switched off. ● The power supply units are faulty.
3	System status indicator	SYS	Off	The system is not operating.
			Green	The system is not operating properly or is starting.
			Orange	The system is performing self-check during startup.
			Blinking green	The system is operating properly.
			Red	After registering, the system does not operate properly, or a power alarm, fan alarm, or temperature alarm is generated.

No.	Indicator	Identifier	Status	Description
4	Mode indicator	MODE	Off	The service interface indicator is in the default mode (STAT).
			Green	The service interface indicator indicates the interface speed. After 45 seconds, the service interface indicator automatically restores to off.
			Red	The service interface indicator indicates the stack ID. After 45 seconds, the service interface indicator automatically restores to off.

As shown in [Figure 6-1](#) and [Figure 6-3](#), the button marked "5" is the mode switching button. When you press the mode switching button once, the mode indicator turns green and the related interface indicator enters the speed state. When you press the mode switching button for a second time, the mode indicator turns red and the related interface indicator represents the stack status. When you press the mode switching button for a third time, the mode indicator restores to the default state (off). If you do not press the mode switching button within 45 seconds, the mode indicator automatically restores to off. The following table describes the meanings of indicators.

Table 6-4 Description of indicators in different modes

Display Mode	Status	Description
STAT	Off	The interface is not connected or has been shut down.
	Green	The interface is connected.
	Blinking green	The interface is sending or receiving data.
Speed	Off	The interface is not connected or has been shut down.
	Green	The interface speed is 10/100 Mbit/s.
	Blinking green	The interface speed is 1000 Mbit/s.

Display Mode	Status	Description
PoE	Off	The interface does not provide remote power.
	Green	The interface is providing remote power.
	Blinking green	<ul style="list-style-type: none"> The power of the powered device (PD) exceeds the power supply capability of the port or exceeds the threshold.
Stack	Off	The stack ID of the member switch is not the number of the interface in the off state.
	Green	The device is a not a command switch: <ul style="list-style-type: none"> If the indicator of an interface is always on, the number of this interface is the stack ID of the device. If the first nine interface indicators of the device are always on, the stack ID of the device is 0.
	Blinking green	The device is a command switch: <ul style="list-style-type: none"> If the indicator of an interface blinks, the number of this interface is the stack ID of the device. If the first nine interface indicators of the device blink, the stack ID of the device is 0.

Indicators of a PoE S5700

S5700-28C-PWR-EI is a PoE switch.

Figure 6-4 S5700-28C-PWR-EI indicators

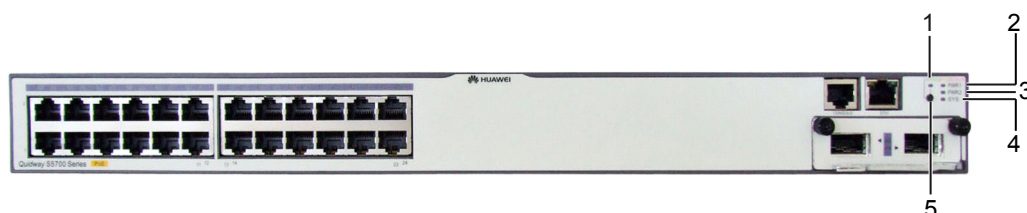

Table 6-5 Description of S5700-28C-PWR-EI indicators

No.	Indicator	Identifier	Status	Description
1	Power indicator	PWR1	Off	The power supply units are not present, or the power supply is abnormal when a single power supply unit is used.
			Green	The power supply is normal.
			Red	<ul style="list-style-type: none"> ● Two power supply units are installed properly, but not switched on. ● The power supply units are switched off. ● The card power and PoE power are abnormal.
			Orange	If a single power supply unit is installed, the PoE power is out of range. If two power supply units are installed, the card power or PoE power is out of range.
2	Power indicator	PWR2	Off	The power supply units are not present, or the power supply is abnormal when a single power supply unit is used.
			Green	The power supply is normal.

No.	Indicator	Identifier	Status	Description
			Red	<ul style="list-style-type: none"> ● Two power supply units are installed properly, but not switched on. ● The power supply units are switched off. ● The card power and PoE power are abnormal.
			Orange	If a single power supply unit is installed, the PoE power is out of range. If two power supply units are installed, the card power or PoE power is out of range.
3	System status indicator	SYS	Off	The system is not operating.
			Green	The system is not operating properly or is starting.
			Orange	The system is performing self-check during startup.
			Blinking green	The system is operating properly.
			Red	After registering, the system does not operate properly, or a power alarm, fan alarm, or temperature alarm is generated.
4	Mode indicator	-	Off	The service interface indicator is in the default mode (STAT).

No.	Indicator	Identifier	Status	Description
			Green	The service interface indicator indicates the interface speed. After 45 seconds, the service interface indicator automatically restores to off.
			Orange	The service interface indicator indicates the PoE status. After 45 seconds, the service interface indicator automatically restores to off.
			Red	The service interface indicator indicates the stack ID. After 45 seconds, the service interface indicator automatically restores to off.

As shown in [Figure 6-4](#), the button marked "5" is the mode switching button. On an S5700, you can press the mode switching button to switch the display modes of interface indicators. The status of a mode indicator represents the display mode of the related interface indicator. For example, the mode indicator of S5700-28C-PWR-EI is off and the interface indicators are in STAT state by default. When you press the mode switching button once, the mode indicator turns green and the related interface indicator enters the speed state. When you press the mode switching button for a second time, the mode indicator turns orange and the related interface indicator represents the PoE power status. When you press the mode switching button for a third time, the mode indicator turns red and the related interface indicator represents the stack status. When you press the mode switching button for a fourth time, the mode indicator restores to the default state (off). If you do not press the mode switching button within 45 seconds, the mode indicator automatically restores to off.

The following table describes the meanings of indicators.

Table 6-6 Description of indicators in different modes

Display Mode	Status	Description
STAT	Off	The interface is not connected or has been shut down.
	Green	The interface is connected.

Display Mode	Status	Description
	Blinking green	The interface is sending or receiving data.
Speed	Off	The interface is not connected or has been shut down.
	Green	The interface speed is 10/100 Mbit/s.
	Blinking green	The interface speed is 1000 Mbit/s.
PoE	Off	The interface does not provide remote power.
	Green	The interface is providing remote power.
	Blinking green	<ul style="list-style-type: none"> The power of the powered device (PD) exceeds the power supply capability of the port or exceeds the threshold.
Stack	Off	The stack ID of the member switch is not the number of the interface in the off state.
	Green	<p>The device is a not a command switch:</p> <ul style="list-style-type: none"> If the indicator of an interface is always on, the number of this interface is the stack ID of the device. If the first nine interface indicators of the device are always on, the stack ID of the device is 0.
	Blinking green	<p>The device is a command switch:</p> <ul style="list-style-type: none"> If the indicator of an interface blinks, the number of this interface is the stack ID of the device. If the first nine interface indicators of the device blink, the stack ID of the device is 0.

6.2 Fan Indicators

This section describes the fan indicators.

The S5700 fan module consists of two fans. The fans can be replaced when the device is operating.

Figure 6-5 Fan module appearance

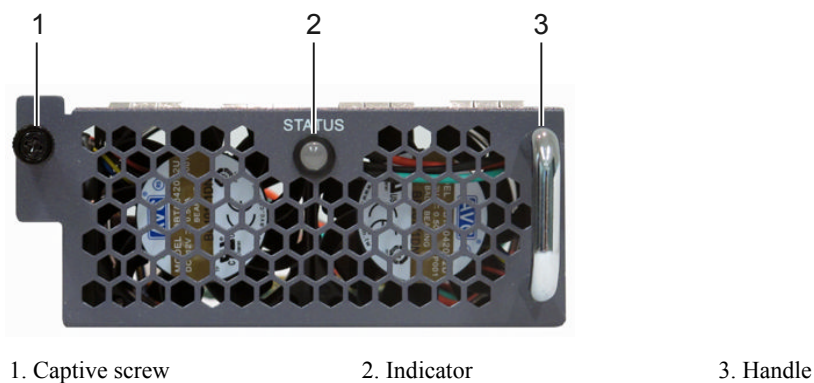

Table 6-7 describes the fan indicators.

Table 6-7 Fan indicator description

Name	Color	Description
STATUS	Blinking green (1 Hz)	The fan module is operating properly.
	Blinking red (1 Hz)	The fan module is faulty.

6.3 Power Indicators

This section describes the power indicators.

Non-PoE Power Indicators

The non-PoE power indicators are displayed on the panel of the power supply unit through the lamp guide. For the indicator description, see [Table 6-8](#), [Table 6-9](#), [Table 6-10](#), and [Table 6-11](#).

 **NOTE**

If a switch does not have a power supply unit, see section [6.1 Indicators on the Front Panel](#) for the PWR indicator description.

Figure 6-6 shows the appearance of the DC power supply unit.

Figure 6-6 Appearance of the 150 W DC power supply unit

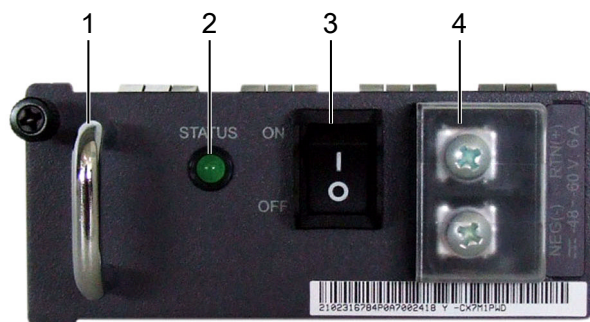

1. Handle 2. Indicator 3. Switch 4. DC jack

Table 6-8 Description of the 150 W DC power indicators

Name	Status	Description
STATUS	Off	<ul style="list-style-type: none"> The input power is out of range, for example, no DC input power, DC input overvoltage, and DC input undervoltage. The output power is out of range, for example, undervoltage or overtemperature occurs.
	Green	The DC input power is within range.
	Blinking green	The output power is out of range, for example, overvoltage, overcurrent, or short circuit occurs.

Figure 6-7 shows the appearance of the DC power supply unit.

Figure 6-7 Appearance of the 150 W AC power supply unit

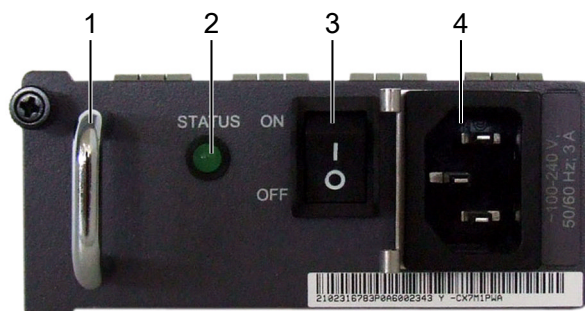

1. Handle 2. Indicator 3. Switch 4. AC jack

Table 6-9 Description of the 150 W AC power indicators

Name	Status	Description
STATUS	Off	<ul style="list-style-type: none"> The input power is out of range, for example, no AC input power, AC input overvoltage, and AC input undervoltage. The output power is out of range, for example, undervoltage or overtemperature occurs.
	Green	The AC input power is within range.
	Blinking green	The output power is out of range, for example, overvoltage, overcurrent, or short circuit occurs.

Figure 6-8 shows the appearance of the 170 W DC power supply unit.

Figure 6-8 Appearance of the 170 W DC power supply unit

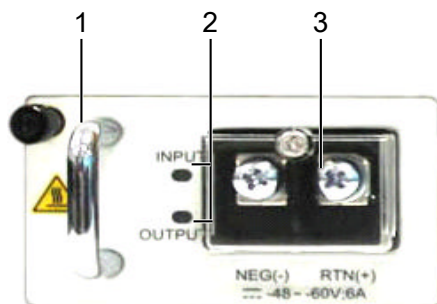

1. Handle

2. Indicator

3. DC jack

Table 6-10 Description of the 170 W DC power indicators

Name	Status	Description
INPUT	Green	The DC input power is within range.
	Off	The DC input power is out of range or no DC input power.
OUTPUT	Green	The DC output power is within range.
	Blinking green	The output power is out of range, for example, overvoltage, overcurrent, or short circuit occurs.
	Off	The DC output power is out of range.

Figure 6-9 shows the appearance of the 170 W AC power supply unit.

Figure 6-9 Appearance of the 170 W AC power supply unit

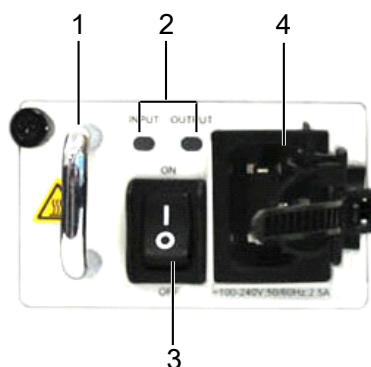

1. Handle

2. Indicator

3. Switch

4. AC jack

Table 6-11 Description of the 170 W AC power indicators

Name	Status	Description
INPUT	Green	The AC input power is within range.
	Off	The AC input power is out of range or no AC input power.
OUTPUT	Green	The AC output power is within range.
	Blinking green	The output power is out of range, for example, overvoltage, overcurrent, or short circuit occurs.
	Off	The AC output power is out of range.

AC PoE Power Indicators

Figure 6-10 Appearance of the 250 W AC PoE power supply unit

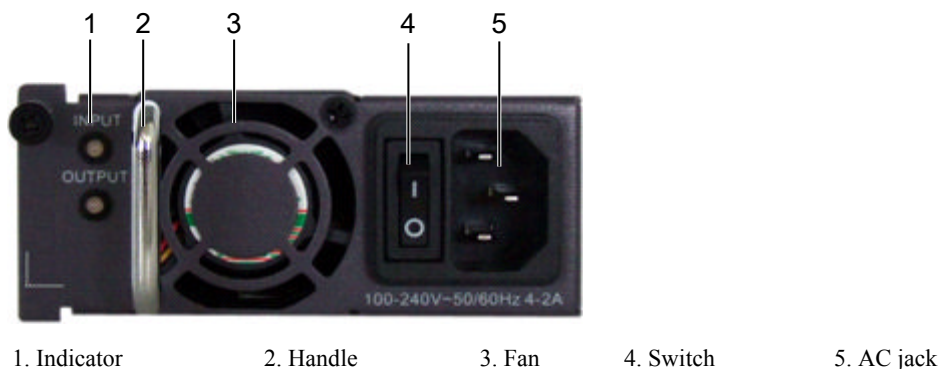

Figure 6-11 Appearance of the 500 W AC PoE power supply unit

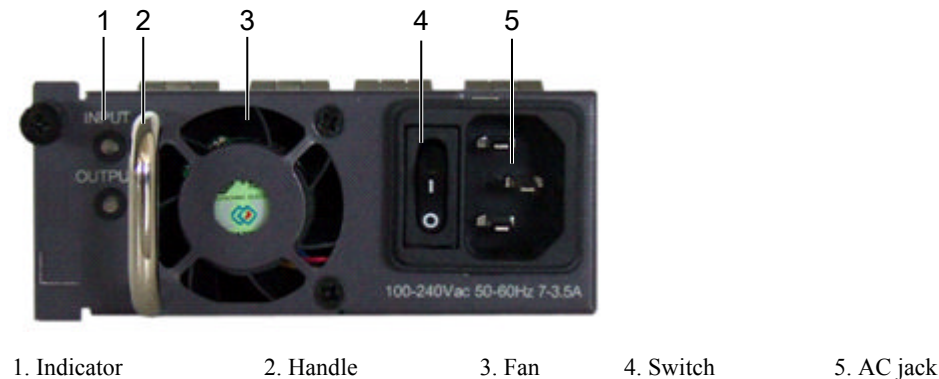

Table 6-12 describes the AC PoE power indicators.

Table 6-12 Description of the AC PoE power indicators

Name	Status	Description
INPUT	Green	The input power is within range.
	Red	The input power is out of range, for example: <ul style="list-style-type: none"> ● Undervoltage ● Overvoltage
	Off	The power cable is loose or no input AC power is provided.
OUTPUT	Green	The AC output power is within range.
	Red	The output power is out of range, for example: <ul style="list-style-type: none"> ● Abnormal power fan operation ● Output overvoltage ● Output overcurrent ● Short circuit ● Overtemperature
	Off	The power cable is loose or no input AC power is provided.

7 List of Optical Modules

About This Chapter

This section describes the attributes of optical modules supported by the S5700.

[7.1 ESFP Optical Module \(FE\) Attributes](#)

This section describes the attributes of an ESFP optical module (FE).

[7.2 ESFP Optical Module \(GE\) Attributes](#)

This section describes the attributes of an ESFP optical module (GE).

[7.3 ESFP CWDM-SFP Optical Module](#)

This section describes the attributes of an ESFP CWDM-SFP optical module.

[7.4 XFP Optical Module \(10GE\) Attributes](#)

This section describes the attributes of an XFP optical module (10GE).

[7.5 SFP+ Optical Module \(10GE\) Attributes](#)

This section describes the attributes of an SFP+ optical module (10GE).

7.1 ESFP Optical Module (FE) Attributes

This section describes the attributes of an ESFP optical module (FE).

Table 7-1 ESFP optical module (FE) attributes

Item	Description				
Transmission distance	15 km	15 km (single-mode bidirectional fiber)	15 km (single-mode bidirectional fiber)	40 km	80 km
Center wavelength	1310 nm	Tx: 1310 nm Rx: 1550 nm	Tx: 1550 nm Rx: 1310 nm	1310 nm	1550 nm
Transmitting power	-15.0 dBm to -8.0 dBm	-15.0 dBm to -8.0 dBm	-15.0 dBm to -8.0 dBm	-5.0 dBm to 0 dBm	-5.0 dBm to 0 dBm
Receiver sensitivity	-31.0 dBm	-32.0 dBm	-32.0 dBm	-34.0 dBm	-34.0 dBm
Overload power	-8.0 dBm	-8.0 dBm	-8.0 dBm	-10.0 dBm	-10.0 dBm
Extinction ratio	8.2 dB	8.5 dB	8.5 dB	10.0 dB	10.5 dB
Connector type	LC	LC/PC	LC/PC	LC	LC
Fiber type	Single-mode				

 **NOTE**

The ESFP optical module (FE) is applicable to only the 100M SFP optical interfaces or 100M/1000M SFP optical interfaces.

7.2 ESFP Optical Module (GE) Attributes

This section describes the attributes of an ESFP optical module (GE).

Table 7-2 ESFP optical module (GE) attributes

Item	Description							
Transmission distance	0.5 km	10 km	10 km (single-mode bidirectional fiber)	10 km (single-mode bidirectional fiber)	40 km	40 km	80 km	100 km
Center wavelength	850 nm	1310 nm	Tx: 1310 nm Rx: 1490 nm	Tx: 1490 nm Rx: 1310 nm	1550 nm	1310 nm	1550 nm	1550 nm
Transmitting power	-9.5 dBm to -2.5 dBm	-9.0 dBm to -3.0 dBm	-9.0 dBm to -3.0 dBm	-9.0 dBm to -3.0 dBm	-5.0 dBm to 0 dBm	-5.0 dBm to 0 dBm	-2.0 dBm to 5.0 dBm	0 dBm to 5.0 dBm
Receiver sensitivity	-17.0 dBm	-20.0 dBm	-19.5 dBm	-19.5 dBm	-22.0 dBm	-23.0 dBm	-22.0 dBm	-30.0 dBm
Overload power	0 dBm	-3.0 dBm	-3.0 dBm	-3.0 dBm	-3.0 dBm	-3.0 dBm	-3.0 dBm	-9.0 dBm
Extinction ratio	9.0 dB	9.5 dB	6.0 dB	6.0 dB	9.0 dB	9.0 dB	9.0 dB	9.0 dB
Connector type	LC							
Fiber type	Multi-mode	Single-mode						



NOTE

The ESFP optical module (GE) is applicable to only the 1000M SFP optical interfaces or 100M/1000M SFP optical interfaces or GE SFP/10G SFP+ Optical Interface.

7.3 ESFP CWDM-SFP Optical Module

This section describes the attributes of an ESFP CWDM-SFP optical module.

Table 7-3 ESFP CWDM-SFP optical module attributes

Item	Description							
Transmission distance	80 km							
Center wavelength	1471 nm	1491 nm	1511 nm	1531 nm	1551 nm	1571 nm	1591 nm	1611 nm
Transmitting power	0 dBm to 5.0 dBm							
Receiver sensitivity	-28.0 dBm							
Overload power	-9.0 dBm							
Extinction ratio	8.2 dB							
Connector type	LC							
Fiber type	Single-mode							

 **NOTE**

The ESFP CWDM-SFP optical module is applicable to only the 100M SFP optical interfaces or 1000M SFP optical interfaces or 100M/1000M SFP optical interfaces or GE SFP/10G SFP+ Optical Interface.

7.4 XFP Optical Module (10GE) Attributes

This section describes the attributes of an XFP optical module (10GE).

Table 7-4 XFP optical module (10GE) attributes

Item	Description			
Transmission distance	0.3 km	10 km	40 km	80 km
Center wavelength	850 nm	1310 nm	1550 nm	1550 nm
Transmitting power	-7.3 dBm to -1.0 dBm	-6.0 dBm to -1.0 dBm	-4.7 dBm to 4.0 dBm	0 dBm to 4.0 dBm

Item	Description			
Receiver sensitivity	-7.5 dBm	-14.4 dBm	-14.0 dBm	-24.0 dBm
Overload power	-1.0 dBm	0.5 dBm	-1.0 dBm	-7.0 dBm
Extinction ratio	3.0 dB	6.0 dB	8.2 dB	9.0 dB
Connector type	LC			
Fiber type	Multi-mode	Single-mode		

7.5 SFP+ Optical Module (10GE) Attributes

This section describes the attributes of an SFP+ optical module (10GE).

Table 7-5 SFP+ optical module (10GE) attributes

Item	Description			
Transmission distance	0.22 km	0.3 km	10 km	40 km
Center wavelength	1310 nm	850 nm	1310 nm	1550 nm
Transmitting power	-6.5 dBm to -0.5 dBm	-7.3 dBm to -1.0 dBm	-8.2 dBm to 0.5 dBm	-4.7 dBm to 4.0 dBm
Receiver sensitivity	-6.5 dBm	-11.1 dBm	-12.6 dBm	-14.1 dBm
Overload power	1.5 dBm	-1.0 dBm	0.5 dBm	-1.0 dBm
Extinction ratio	3.5 dB	3.0 dB	3.5 dB	3.0 dB
Connector type	LC			
Fiber type	Multi-mode		Single-mode	

 **NOTE**

The SFP+ optical modules (10GE) are applicable to only 10G SFP+ optical interfaces.