



S5700 Series Ethernet Switches

Hardware Description

Issue **06**

Date **2013-06-04**

Copyright © Huawei Technologies Co., Ltd. 2013. All rights reserved.

No part of this document may be reproduced or transmitted in any form or by any means without prior written consent of Huawei Technologies Co., Ltd.

Trademarks and Permissions



HUAWEI and other Huawei trademarks are trademarks of Huawei Technologies Co., Ltd.

All other trademarks and trade names mentioned in this document are the property of their respective holders.

Notice

The purchased products, services and features are stipulated by the contract made between Huawei and the customer. All or part of the products, services and features described in this document may not be within the purchase scope or the usage scope. Unless otherwise specified in the contract, all statements, information, and recommendations in this document are provided "AS IS" without warranties, guarantees or representations of any kind, either express or implied.

The information in this document is subject to change without notice. Every effort has been made in the preparation of this document to ensure accuracy of the contents, but all statements, information, and recommendations in this document do not constitute a warranty of any kind, express or implied.

Huawei Technologies Co., Ltd.

Address: Huawei Industrial Base
Bantian, Longgang
Shenzhen 518129
People's Republic of China

Website: <http://enterprise.huawei.com>

About This Document

Intended Audience





This document provides an overall description of the S5700, which helps you obtain detailed information about each chassis, card, power module, fan module, cable, and optical module.

This document is intended for:

- Network planning engineers
- Hardware installation engineers
- Commissioning engineers
- On-site maintenance engineers
- System maintenance engineers

Symbol Conventions

The symbols that may be found in this document are defined as follows.

Symbol	Description
 DANGER	Indicates a hazard with a high level or medium level of risk which, if not avoided, could result in death or serious injury.
 WARNING	Indicates a hazard with a low level of risk which, if not avoided, could result in minor or moderate injury.
 CAUTION	Indicates a potentially hazardous situation that, if not avoided, could result in equipment damage, data loss, performance deterioration, or unanticipated results.
 TIP	Provides a tip that may help you solve a problem or save time.
 NOTE	Provides additional information to emphasize or supplement important points in the main text.

Command Conventions

The command conventions that may be found in this document are defined as follows.

Convention	Description
Boldface	The keywords of a command line are in boldface .
<i>Italic</i>	Command arguments are in <i>italics</i> .
[]	Items (keywords or arguments) in brackets [] are optional.
{ x y ... }	Optional items are grouped in braces and separated by vertical bars. One item is selected.
[x y ...]	Optional items are grouped in brackets and separated by vertical bars. One item is selected or no item is selected.
{ x y ... }*	Optional items are grouped in braces and separated by vertical bars. A minimum of one item or a maximum of all items can be selected.
[x y ...]*	Optional items are grouped in brackets and separated by vertical bars. You can select one or several items, or select no item.
&<1-n>	The parameter before the & sign can be repeated 1 to n times.
#	A line starting with the # sign is comments.

Change History

Changes between document issues are cumulative. The latest document issue contains all changes made to previous issues.

Changes in Issue 06 (2013-06-04)

This version has the following updates:

The following information is modified:

- [2.3 S5700-LI](#)

Changes in Issue 05 (2013-05-17)

This version has the following updates:

The following information is modified:

- [7.2 SFP/eSFP Modules](#)

Changes in Issue 04 (2013-05-05)

This version has the following updates:

The following information is modified:

- [2.6.7 Specifications](#)

Changes in Issue 03 (2013-04-20)

This version has the following updates:

The following information is modified:

- [2.3.2 Appearance and Structure](#)
- [6.2 Stack Cable](#)

Changes in Issue 02 (2013-02-08)

This version has the following updates:

The documentation is modified according to updates in product features.

Changes in Issue 01 (2012-12-08)

Initial commercial release.

Contents

About This Document.....	ii
1 Version Description.....	1
2 Chassis.....	8
2.1 Chassis Overview.....	9
2.2 Naming Rules.....	9
2.3 S5700-LI.....	11
2.3.1 Version Mapping.....	11
2.3.2 Appearance and Structure.....	12
2.3.3 Indicator Description.....	16
2.3.4 Port Description.....	33
2.3.5 Power Supply.....	36
2.3.6 Heat Dissipation.....	38
2.3.7 Specifications.....	40
2.4 S5700S-LI.....	45
2.4.1 Version Mapping.....	45
2.4.2 Appearance and Structure.....	46
2.4.3 Indicator Description.....	47
2.4.4 Port Description.....	50
2.4.5 Power Supply.....	52
2.4.6 Heat Dissipation.....	52
2.4.7 Specifications.....	53
2.5 S5700-SI.....	55
2.5.1 Version Mapping.....	55
2.5.2 Appearance and Structure.....	56
2.5.3 Indicator Description.....	60
2.5.4 Port Description.....	71
2.5.5 Power Supply.....	73
2.5.6 Heat Dissipation.....	77
2.5.7 Specifications.....	77
2.6 S5700-EI.....	81
2.6.1 Version Mapping.....	81
2.6.2 Appearance and Structure.....	82

2.6.3 Indicator Description.....	84
2.6.4 Port Description.....	90
2.6.5 Power Supply.....	92
2.6.6 Heat Dissipation.....	94
2.6.7 Specifications.....	95
2.7 S5700-HI.....	98
2.7.1 Version Mapping.....	98
2.7.2 Appearance and Structure.....	99
2.7.3 Indicator Description.....	100
2.7.4 Port Description.....	103
2.7.5 Power Supply.....	105
2.7.6 Heat Dissipation.....	106
2.7.7 Specifications.....	107
2.8 S5710-EI.....	110
2.8.1 Version Mapping.....	110
2.8.2 Appearance and Structure.....	110
2.8.3 Indicator Description.....	112
2.8.4 Port Description.....	120
2.8.5 Power Supply.....	123
2.8.6 Heat Dissipation.....	125
2.8.7 Specifications.....	126
3 Power Module.....	131
3.1 150 W AC Power Module.....	132
3.2 150 W DC Power Module.....	134
3.3 170 W AC Power Module.....	137
3.4 170 W DC Power Module.....	140
3.5 250 W AC PoE Power Module.....	143
3.6 500 W AC PoE Power Module.....	146
3.7 580 W AC PoE Power Module.....	149
3.8 1150 W AC PoE Power Module.....	153
3.9 RPS1800 Power Supply.....	156
3.10 870 W DC Power Module.....	161
4 Fan Module.....	165
4.1 CX7E1FANA Fan Module.....	166
5 Cards.....	169
5.1 Introduction.....	170
5.1.1 Card Classification.....	170
5.1.2 Card Structure and Dimensions.....	171
5.1.3 Port Numbering.....	172
5.2 ES5D000X2S00/ES5D000X4S01 (2/4-Port 10GE SFP+ Front Optical Interface Card).....	173
5.2.1 Introduction.....	173

5.2.2 Version Mapping.....	174
5.2.3 Functions and Features.....	175
5.2.4 Usage Constraints.....	175
5.2.5 Indicators and Ports.....	175
5.2.6 Specifications.....	178
5.2.7 Ordering Information.....	179
5.3 ES5D000G4S01/ES5D00G4SA01 (4-Port GE SFP Front Optical Interface Card).....	179
5.3.1 Introduction.....	179
5.3.2 Version Mapping.....	180
5.3.3 Functions and Features.....	181
5.3.4 Usage Constraints.....	181
5.3.5 Indicators and Ports.....	182
5.3.6 Specifications.....	183
5.3.7 Order Information.....	184
5.4 ES5D00X2SA00/ES5D00X4SA00 (2/4-Port GE SFP/10GE SFP+ Front Optical Interface Card).....	185
5.4.1 Introduction.....	185
5.4.2 Version Mapping.....	186
5.4.3 Functions and Features.....	186
5.4.4 Indicators and Ports.....	187
5.4.5 Specifications.....	189
5.4.6 Ordering Information.....	190
5.5 ES5D00G4SC00 (4-Port GE SFP Front Optical Interface Card).....	191
5.5.1 Introduction.....	191
5.5.2 Version Mapping.....	191
5.5.3 Functions and Features.....	192
5.5.4 Indicators and Ports.....	192
5.5.5 Specifications.....	194
5.5.6 Ordering Information.....	195
5.6 ES5D21G08S00 (8-Port GE SFP Rear Optical Interface Card).....	195
5.6.1 Introduction.....	195
5.6.2 Version Mapping.....	196
5.6.3 Functions and Features.....	196
5.6.4 Indicators and Ports.....	196
5.6.5 Specifications.....	198
5.6.6 Ordering Information.....	199
5.7 ES5D21G08T00 (8-Port GE Rear Electrical Interface Card).....	200
5.7.1 Introduction.....	200
5.7.2 Version Mapping.....	200
5.7.3 Functions and Features.....	201
5.7.4 Indicators and Ports.....	201
5.7.5 Specifications.....	203
5.7.6 Ordering Information.....	204

5.8 ES5D21X02S00 (2-Port GE SFP/10GE SFP+ Rear Optical Interface Card).....	204
5.8.1 Introduction.....	204
5.8.2 Version Mapping.....	205
5.8.3 Functions and Features.....	205
5.8.4 Indicators and Ports.....	206
5.8.5 Specifications.....	207
5.8.6 Ordering Information.....	208
5.9 ES5D00ETPC00 (Stack Rear Card).....	208
5.9.1 Introduction.....	209
5.9.2 Version Mapping.....	209
5.9.3 Functions and Features.....	209
5.9.4 Usage Constraints.....	211
5.9.5 Port Description.....	211
5.9.6 Specifications.....	212
5.9.7 Ordering Information.....	213
5.10 ES5D00ETPB00 (Extended Rear Card).....	213
5.10.1 Introduction.....	213
5.10.2 Version Mapping.....	214
5.10.3 Functions and Features.....	214
5.10.4 Usage Constraints.....	215
5.10.5 Specifications.....	215
5.10.6 Ordering Information.....	216
6 Cables.....	217
6.1 Ground Cable.....	218
6.2 Stack Cable.....	218
6.3 Optical Fiber.....	224
6.4 Network Cable.....	227
6.5 DC Power Cable.....	229
6.6 AC Power Cable.....	231
6.7 RPS1800 Power Cable.....	232
6.8 RPS Cable.....	233
6.9 Console Cable.....	233
7 Optical Module.....	236
7.1 Basic Concepts.....	237
7.2 SFP/eSFP Modules.....	239
7.3 SFP+ Modules.....	247

1 Version Description

 **NOTE**

The availability of device models and modules described in this document will be specified in the product change notices (PCNs). For details, contact the product manager of Huawei local office.

Available Models

Table 1-1 lists the switch models available in V200R002C00.

Table 1-1 Switch models available in V200R002C00

Series	Model	Maximum Number of Interfaces
S5700-LI	S5700-28P-LI-AC	28 There are twenty-four 10/100/1000BASE-T Ethernet electrical interfaces and four 1000BASE-X Ethernet optical interfaces.
	S5700-28P-LI-DC	28 There are twenty-four 10/100/1000BASE-T Ethernet electrical interfaces and four 1000BASE-X Ethernet optical interfaces.
	S5700-52P-LI-AC	52 There are forty-eight 10/100/1000BASE-T Ethernet electrical interfaces and four 1000BASE-X Ethernet optical interfaces.
	S5700-52P-LI-DC	52 There are forty-eight 10/100/1000BASE-T Ethernet electrical interfaces and four 1000BASE-X Ethernet optical interfaces.
	S5700-28P-PWR-LI-AC	28 There are twenty-four 10/100/1000BASE-T Ethernet electrical interfaces and four 1000BASE-X Ethernet optical interfaces.

Series	Model	Maximum Number of Interfaces
	S5700-52P-PWR-LI-AC	52 There are forty-eight 10/100/1000BASE-T Ethernet electrical interfaces and four 1000BASE-X Ethernet optical interfaces.
	S5700-28X-LI-AC	28 There are twenty-four 10/100/1000BASE-T Ethernet electrical interfaces and four 10GE SFP+ optical interfaces (working in auto-sensing mode and changing to GE interfaces).
	S5700-28X-LI-DC	28 There are twenty-four 10/100/1000BASE-T Ethernet electrical interfaces and four 10GE SFP+ optical interfaces (working in auto-sensing mode and changing to GE interfaces).
	S5700-52X-LI-AC	52 There are forty-eight 10/100/1000BASE-T Ethernet electrical interfaces and four 10GE SFP+ optical interfaces (working in auto-sensing mode and changing to GE interfaces).
	S5700-52X-LI-DC	52 There are forty-eight 10/100/1000BASE-T Ethernet electrical interfaces and four 10GE SFP+ optical interfaces (working in auto-sensing mode and changing to GE interfaces).
	S5700-28X-PWR-LI-AC	28 There are twenty-four 10/100/1000BASE-T Ethernet electrical interfaces and four 10GE SFP+ optical interfaces (working in auto-sensing mode and changing to GE interfaces).
	S5700-52X-PWR-LI-AC	52 There are forty-eight 10/100/1000BASE-T Ethernet electrical interfaces and four 10GE SFP+ optical interfaces (working in auto-sensing mode and changing to GE interfaces).
	S5700-10P-PWR-LI-AC	10 There are eight 10/100/1000BASE-T Ethernet electrical interfaces and two 1000BASE-X Ethernet optical interfaces.
	S5700-10P-LI-AC	10 There are eight 10/100/1000BASE-T Ethernet electrical interfaces and two 1000BASE-X Ethernet optical interfaces.

Series	Model	Maximum Number of Interfaces
	S5700-28TP-LI-AC	28 There are twenty-four 10/100/1000BASE-T Ethernet electrical interfaces, two GE combo interfaces (10/100/1000BASE-T+100/1000BASE-X), and two 1000BASE-X Ethernet optical interfaces.
	S5700-28TP-PWR-LI-AC	28 There are twenty-four 10/100/1000BASE-T Ethernet electrical interfaces, two GE combo interfaces (10/100/1000BASE-T+100/1000BASE-X), and two 1000BASE-X Ethernet optical interfaces.
	S5701-28TP-PWR-LI-AC	28 There are twenty-four 10/100/1000BASE-T Ethernet electrical interfaces, two GE combo interfaces (10/100/1000BASE-T+100/1000BASE-X), and two 1000BASE-X Ethernet optical interfaces.
S5700S-LI	S5700S-28P-LI-AC	28 There are twenty-four 10/100/1000BASE-T Ethernet electrical interfaces and four 1000BASE-X Ethernet optical interfaces.
	S5700S-52P-LI-AC	52 There are forty-eight 10/100/1000BASE-T Ethernet electrical interfaces and four 1000BASE-X Ethernet optical interfaces.
S5700-SI	S5700-28C-SI	28 There are twenty 10/100/1000BASE-T Ethernet electrical interfaces, four GE combo interfaces (10/100/1000BASE-T+100/1000BASE-X), and four interfaces on the front card.
	S5700-28C-PWR-SI	28 There are twenty 10/100/1000BASE-T Ethernet electrical interfaces, four GE combo interfaces (10/100/1000BASE-T+100/1000BASE-X), and four interfaces on the front card.
	S5700-52C-SI	52 There are forty-eight 10/100/1000BASE-T Ethernet electrical interfaces and four interfaces on the front card.
	S5700-52C-PWR-SI	52 There are forty-eight 10/100/1000BASE-T Ethernet electrical interfaces and four interfaces on the front card.

Series	Model	Maximum Number of Interfaces
	S5700-24TP-SI-AC	24 There are twenty 10/100/1000BASE-T Ethernet electrical interfaces and four GE combo interfaces (10/100/1000BASE-T+100/1000BASE-X).
	S5700-24TP-SI-DC	24 There are twenty 10/100/1000BASE-T Ethernet electrical interfaces and four GE combo interfaces (10/100/1000BASE-T+100/1000BASE-X).
	S5700-48TP-SI-AC	48 There are forty-four 10/100/1000BASE-T Ethernet electrical interfaces and four GE combo interfaces (10/100/1000BASE-T+100/1000BASE-X).
	S5700-48TP-SI-DC	48 There are forty-four 10/100/1000BASE-T Ethernet electrical interfaces and four GE combo interfaces (10/100/1000BASE-T+100/1000BASE-X).
	S5700-24TP-PWR-SI	24 There are twenty 10/100/1000BASE-T Ethernet electrical interfaces and four GE combo interfaces (10/100/1000BASE-T+100/1000BASE-X).
	S5700-48TP-PWR-SI	48 There are forty-four 10/100/1000BASE-T Ethernet electrical interfaces and four GE combo interfaces (10/100/1000BASE-T+100/1000BASE-X).
	S5700-26X-SI-12S-AC	26 There are twelve 10/100/1000BASE-T Ethernet electrical interfaces, twelve 1000BASE-X Ethernet optical interfaces, and two 10GE SFP+ optical interfaces (working in auto-sensing mode and changing to GE interfaces).
S5700-EI	S5700-28C-EI	28 There are twenty-four 10/100/1000BASE-T Ethernet electrical interfaces and four interfaces on the front card.
	S5700-52C-EI	52 There are forty-eight 10/100/1000BASE-T Ethernet electrical interfaces and four interfaces on the front card.

Series	Model	Maximum Number of Interfaces
	S5700-28C-EI-24S	28 There are twenty 100/1000BASE-X Ethernet optical interfaces, four GE combo interfaces (10/100/1000BASE-T+100/1000BASE-X), and four interfaces on the front card.
	S5700-28C-PWR-EI	28 There are twenty-four 10/100/1000BASE-T Ethernet electrical interfaces and four interfaces on the front card.
	S5700-52C-PWR-EI	52 There are forty-eight 10/100/1000BASE-T Ethernet electrical interfaces and four interfaces on the front card.
S5700-HI	S5700-28C-HI	28 There are twenty-four 10/100/1000BASE-T Ethernet electrical interfaces and four interfaces on the front card.
	S5700-28C-HI-24S	28 There are twenty-four 100/1000BASE-X Ethernet optical interfaces and four interfaces on the front card.
S5710-EI	S5710-28C-EI	44 There are twenty 10/100/1000BASE-T Ethernet electrical interfaces, four GE combo interfaces (10/100/1000BASE-T+100/1000BASE-X), four 10GE SFP+ optical interfaces (10GE/GE auto-sensing), and sixteen interfaces on the two rear cards.
	S5710-52C-EI	68 There are forty-eight 10/100/1000BASE-T Ethernet electrical interfaces, four 10GE SFP+ optical interfaces (10GE/GE auto-sensing), and sixteen interfaces on the two rear cards.
	S5710-28C-PWR-EI-AC	44 There are twenty 10/100/1000BASE-T Ethernet electrical interfaces, four GE combo interfaces (10/100/1000BASE-T+100/1000BASE-X), four 10GE SFP+ optical interfaces (10GE/GE auto-sensing), and sixteen interfaces on the two rear cards.
	S5710-52C-PWR-EI-AC	68 There are forty-eight 10/100/1000BASE-T Ethernet electrical interfaces, four 10GE SFP+ optical interfaces (10GE/GE auto-sensing), and sixteen interfaces on the two rear cards.

Series	Model	Maximum Number of Interfaces
	S5710-52C-PWR-EI	68 There are forty-eight 10/100/1000BASE-T Ethernet electrical interfaces, four 10GE SFP+ optical interfaces (10GE/GE auto-sensing), and sixteen interfaces on the two rear cards.

Available Power Modules

Table 1-2 lists the power modules available in V200R002C00.

Table 1-2 Power modules available in V200R002C00

Power Module Type	Power Module
AC power module	150 W AC Power Module
	170 W AC Power Module
DC power module	150 W DC Power Module
	170 W DC Power Module
RPS power supply	RPS1800
	870 W DC Power Module
AC PoE power module	250 W AC PoE Power Supply
	500 W AC PoE Power Supply
	580 W AC PoE Power Supply
	1150 W AC PoE Power Supply

Available Cards

Table 1-3 lists the cards available in V200R002C00.

Table 1-3 Subcards available in V200R002C00

Card Type	Card Name	Card Description
Front card	ES5D000X2S00	2-port 10GE SFP+ front optical interface card
	ES5D000X4S01	4-port 10GE SFP+ front optical interface card
	ES5D000G4S01	4-port GE front optical interface card

Card Type	Card Name	Card Description
	ES5D00G4SA01	4-port GE front optical interface card
	ES5D00X2SA00	2-port GE SFP/10GE SFP+ front optical interface card
	ES5D00X4SA00	4-port GE SFP/10GE SFP+ front optical interface card
	ES5D00G4SC00	4-port GE SFP front optical interface card
Rear card	ES5D21G08S00	8-port GE SFP rear optical interface card
	ES5D21G08T00	8-port GE rear electrical interface card
	ES5D21X02S00	2-port GE SFP/10GE SFP+ rear optical interface card
	ES5D00ETPC00	Stack rear card
	ES5D00ETPB00	Extended channel rear card

2 Chassis

About This Chapter

[2.1 Chassis Overview](#)

[2.2 Naming Rules](#)

[2.3 S5700-LI](#)

[2.4 S5700S-LI](#)

[2.5 S5700-SI](#)

[2.6 S5700-EI](#)

[2.7 S5700-HI](#)

[2.8 S5710-EI](#)

2.1 Chassis Overview

The S5700 series Ethernet switches (S5700 for short) provide the access, aggregation, and data transport functions. They are developed by Huawei to meet the requirements for reliable access and aggregation and high-quality transmission of multiple services on enterprise networks. The S5700 uses an integrated hardware platform. The S5700 hardware consists of the chassis, power module, fan module, interface card, and switch control unit (SCU).

The S5700 switches include S5700-LI, S5700S-LI, S5700-SI, S5700-EI, S5700-HI, and S5710-EI. Select the chassis model according to your network requirements.



NOTE

The S5700-LI and S5700S-LI do not support hardware forwarding for Layer 3 services.

2.2 Naming Rules

Figure 2-1 shows naming rules of case-shaped switches.

Figure 2-1 Naming rules of case-shaped switches

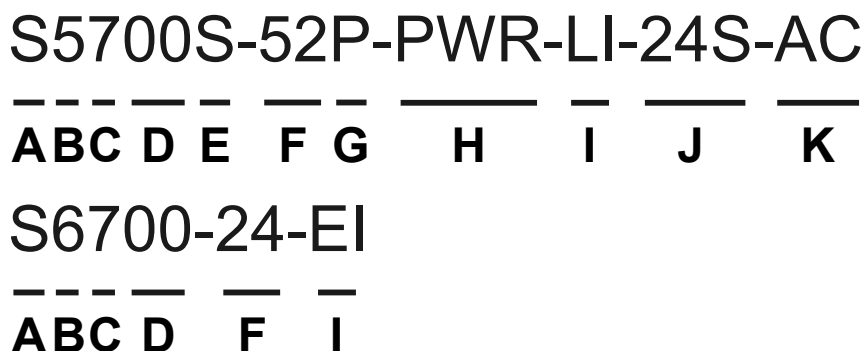

NOTE

The device names in this figure are used as examples and do not represent specified devices.

Table 2-1 lists the naming rules of case-shaped switches.

Table 2-1 Naming rules of case-shaped switches

Identifier	Description
A	Switch

Identifier	Description
B	<ul style="list-style-type: none"> ● 6: 10GE downlink ports ● 5: 1000M downlink ports ● 3: Layer 3 switch with 100M downlink ports ● 2: Layer 2 switch with 100M downlink ports
C	7: Enterprise series switch
D	Product sub-series (such as 00, 10)
E	Resale model NOTE If the letter S is not displayed, this model is a non-resale model.
F	Maximum number of ports NOTE On an S5710-EI switch, this field indicates the number of fixed ports on the switch.
G	Uplink port type: <ul style="list-style-type: none"> ● C: The switch supports cards. Ports of cards function as uplink ports. ● X: The switch has fixed 10GE uplink ports. ● TP: The switch has combo ports that can function as optical and electrical ports. ● P: The switch has uplink optical ports. NOTE If this field is not displayed, the switch has no uplink port.
H	Power over Ethernet (PoE) model NOTE If this field is not displayed, the switch does not support PoE.
I	Software version type <ul style="list-style-type: none"> ● LI: indicates the simplified version. ● SI: indicates the standard version, supporting basic features. ● EI: indicates the enhanced version, supporting enhanced features. ● HI: indicates the advanced version, supporting high-performance operation, administration, and maintenance (OAM) and built-in real-time clock (RTC).
J	Downlink port type. The field 24S indicates that 24 downlink ports of the switch are optical ports. NOTE If the S5700 does not contain this field, all the downlink ports of the switch are electrical ports. The S6700 does not contain this field because all its ports are downlink optical ports.
K	Powering mode: <ul style="list-style-type: none"> ● AC: indicates alternating current power. ● DC: indicates direct current power.

2.3 S5700-LI

2.3.1 Version Mapping

Table 2-2 lists the mapping between the S5700-LI chassis and software versions.

Table 2-2 Mapping between the S5700-LI chassis and software versions

Series	Model	Available Version
S5700-LI	S5700-28P-LI-AC	V200R001C00 and later versions
	S5700-28P-LI-DC	V200R001C00 and later versions
	S5700-52P-LI-AC	V200R001C00 and later versions
	S5700-52P-LI-DC	V200R001C00 and later versions
	S5700-28P-PWR-LI-AC	V200R001C00 and later versions
	S5700-52P-PWR-LI-AC	V200R001C00 and later versions
	S5700-10P-PWR-LI-AC	V200R002C00 and later versions
	S5700-10P-LI-AC	V200R002C00 and later versions
	S5700-28X-LI-AC	V200R002C00 and later versions
	S5700-28X-LI-DC	V200R002C00 and later versions
	S5700-52X-LI-AC	V200R002C00 and later versions
	S5700-52X-LI-DC	V200R002C00 and later versions
	S5700-28X-PWR-LI-AC	V200R002C00 and later versions
	S5700-52X-PWR-LI-AC	V200R002C00 and later versions

Series	Model	Available Version
	S5700-28TP-LI-AC	V200R002C00 and later versions
	S5700-28TP-PWR-LI-AC	V200R002C00 and later versions
	S5701-28TP-PWR-LI-AC	V200R002C00 and later versions

2.3.2 Appearance and Structure

Front View

Table 2-3 shows the front view of the S5700-LI chassis.

Table 2-3 Front view of the S5700-LI chassis

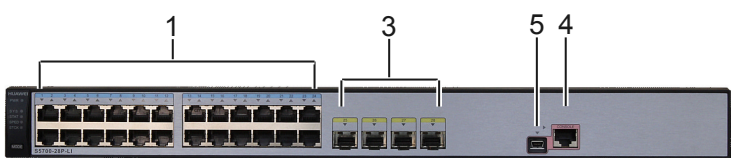
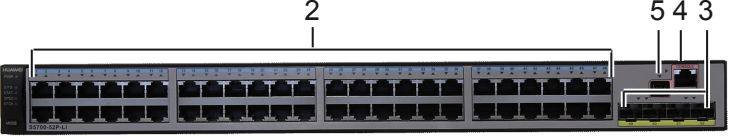
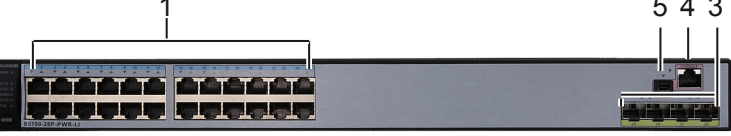
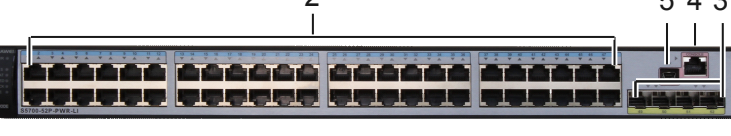
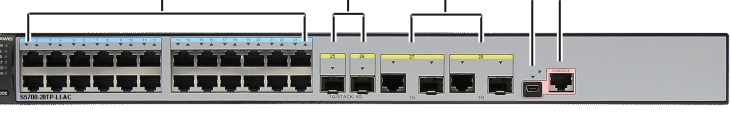
Model	Image
S5700-28P-LI-AC S5700-28P-LI-DC	
S5700-52P-LI-AC S5700-52P-LI-DC	
S5700-28P-PWR-LI-AC	
S5700-52P-PWR-LI-AC	
S5700-28TP-LI-AC	

Model	Image
S5700-28TP-PWR-LI-AC	<p>Diagram showing the front panel of the S5700-28TP-PWR-LI-AC switch. Callout 1 points to the 28 RJ45 ports. Callout 8 points to the first SFP port. Callout 9 points to the second SFP port. Callout 5 points to the power jack. Callout 4 points to the power button.</p>
S5701-28TP-PWR-LI-AC	<p>Diagram showing the front panel of the S5701-28TP-PWR-LI-AC switch. Callout 1 points to the 28 RJ45 ports. Callout 8 points to the first SFP port. Callout 9 points to the second SFP port. Callout 5 points to the power jack. Callout 4 points to the power button.</p>
S5700-28X-LI-AC	<p>Diagram showing the front panel of the S5700-28X-LI-AC switch. Callout 1 points to the 28 RJ45 ports. Callout 6 points to the three SFP ports. Callout 5 points to the power jack. Callout 4 points to the power button.</p>
S5700-28X-LI-DC	<p>Diagram showing the front panel of the S5700-28X-LI-DC switch. Callout 1 points to the 28 RJ45 ports. Callout 6 points to the three SFP ports. Callout 5 points to the power jack. Callout 4 points to the power button.</p>
S5700-52X-LI-AC	<p>Diagram showing the front panel of the S5700-52X-LI-AC switch. Callout 2 points to the 52 RJ45 ports. Callout 5 points to the power jack. Callout 4 points to the power button. Callout 6 points to the SFP ports.</p>
S5700-52X-LI-DC	<p>Diagram showing the front panel of the S5700-52X-LI-DC switch. Callout 2 points to the 52 RJ45 ports. Callout 5 points to the power jack. Callout 4 points to the power button. Callout 6 points to the SFP ports.</p>
S5700-28X-PWR-LI-AC	<p>Diagram showing the front panel of the S5700-28X-PWR-LI-AC switch. Callout 1 points to the 28 RJ45 ports. Callout 5 points to the power jack. Callout 4 points to the power button. Callout 6 points to the SFP ports.</p>
S5700-52X-PWR-LI-AC	<p>Diagram showing the front panel of the S5700-52X-PWR-LI-AC switch. Callout 2 points to the 52 RJ45 ports. Callout 5 points to the power jack. Callout 4 points to the power button. Callout 6 points to the SFP ports.</p>

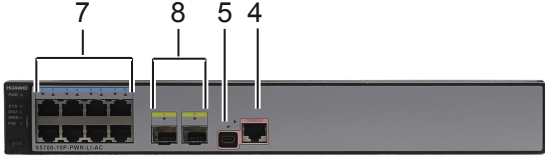
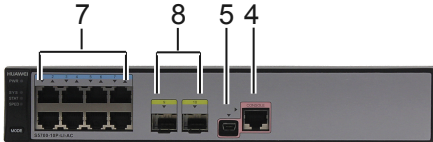
Model	Image
S5700-10P-PWR-LI-AC	
S5700-10P-LI-AC	





1. Twenty-four 10/100/1000BASE-T Ethernet electrical ports	2. Forty-eight 10/100/1000BASE-T Ethernet electrical ports	3. Four 1000BASE-X Ethernet optical ports	4. One console port
5. One Mini USB port	6. Four 10GE SFP+ Ethernet optical ports	7. Eight 10/100/1000BASE-T Ethernet electrical ports	8. Two 1000BASE-X Ethernet optical ports
9. Two combo ports (10/100/1000BASE-T+100/1000BASE-X)	-	-	-

Rear View

Table 2-4 shows the rear view of the S5700-LI chassis.

Table 2-4 Rear view of the S5700-LI chassis

Model	Image
S5700-28P-LI-AC S5700-28TP-LI-AC S5700-52P-LI-AC S5700-28X-LI-AC S5700-52X-LI-AC	

Model	Image
S5700-28P-LI-DC S5700-52P-LI-DC S5700-28X-LI-DC S5700-52X-LI-DC	
S5700-28P-PWR-LI-AC S5700-28TP-PWR-LI-AC S5701-28TP-PWR-LI-AC S5700-52P-PWR-LI-AC S5700-28X-PWR-LI-AC S5700-52X-PWR-LI-AC	
S5700-10P-PWR-LI-AC	
S5700-10P-LI-AC	

<p>1. Ground screw</p> <p>NOTE</p> <p>It is used with a ground cable.</p>	<p>2. RPS socket</p> <p>NOTE</p> <ul style="list-style-type: none"> ● It is used with an RPS cable which is not hot swappable. ● A PoE switch can have an RPS power supply connected to this socket to provide inputs for system power supply and PoE power supply. The two inputs are independent of each other. The RPS power supply can also be used as a backup of the system power supply when it does not provide PoE power input to the switch. 	<p>3. AC socket</p> <p>NOTE</p> <p>It is used with an AC power cable.</p>	<p>4. DC power terminal</p> <p>NOTE</p> <p>It is used with a DC power cable.</p>
<p>5. Jack for AC terminal locking latch</p> <p>NOTE</p> <p>The AC terminal locking latch is not delivered with the device. Customers need to prepare the locking latch themselves if they need it.</p>	-	-	-

2.3.3 Indicator Description

S5700-28P-LI-AC

 **NOTE**

Symbols and meanings of indicators on the S5700-28P-LI-DC, the S5700-52P-LI-AC, and the S5700-52P-LI-DC are the same as those on the S5700-28P-LI-AC.

Figure 2-2 Indicators on the S5700-28P-LI-AC

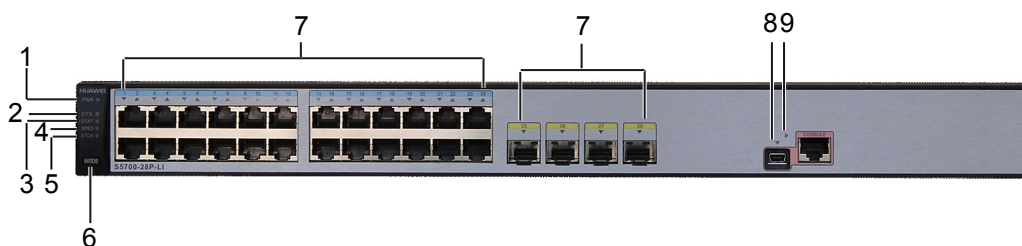

Table 2-5 Description of indicators on the S5700-28P-LI-AC

Number	Indicator/ Button	Color	Description
1	PWR: power supply indicator	Off	The switch is powered off.
		Green	Steady on: The switch is powered on.
		Yellow	Steady on: The internal power module is faulty, and the switch is powered by the RPS system.
2	SYS: system status indicator	Off	The system is not running.
		Green	<ul style="list-style-type: none"> Blinking once every 0.25s (4 Hz): The system is starting. Blinking once every 2s (0.5 Hz): The system is operating properly.
		Yellow	Blinking once every 2s (0.5 Hz): The system is sleeping. NOTE The system can wake from the sleeping state if you press the MODE button.
		Red	Steady on: The system cannot start normally, or a temperature alarm or fan alarm is generated.
3	STAT: status indicator in STAT mode	Off	The STAT mode is not selected.
		Green	Steady on: The service port indicators are in the default mode (STAT).
4	SPED: status indicator in speed mode	Off	The SPED mode is not selected.
		Green	Steady on: The service port indicators indicate the port speed. After 45 seconds, the service port indicators automatically restore to STAT mode.

Number	Indicator/ Button	Color	Description
5	STCK: status indicator in stack mode	Off	The STCK mode is not selected.
		Green	<ul style="list-style-type: none"> ● Steady on: The service port indicators indicate the stack information. After 45 seconds, the service port indicators automatically restore to STAT mode. ● Blinking: The indicator indicates the active switch in a stack or a switch not in any stack.
6	MODE: mode switch button	-	<ul style="list-style-type: none"> ● When you press the button once, the SPED indicator turns green and the service port indicators show the speed of each port. ● When you press the button for a second time, the STCK indicator turns green and the service port indicators show the stack status. ● When you press the button for a third time, the STAT indicator turns green. <p>If you do not press the button within 45 seconds, the indicators restore to the default status. That is, the STAT indicator turns green, and the SPED and STCK indicators are off.</p>
7	Service port indicator <ul style="list-style-type: none"> ● GE electrical ports: The first indicator shows the status of the bottom left port. The indicators correspond to the ports from bottom to top and from left to right. ● GE optical port: Each optical port has a corresponding indicator above it. 	The meaning of the service port indicator varies with the current mode. For details, see Table 2-8 .	

Number	Indicator/Button	Color	Description
8	Mini USB indicator	Off	The Mini USB port is not active, and the console port is active.
		Green	Steady on: The Mini USB port is active. When this LED is on, the console port LED is off.
9	Console indicator	Off	The console port is not active, and the Mini USB port is active.
		Green	Steady on (default): The console port is active. When this LED is on, the Mini USB port LED is off.

S5700-28X-LI-AC

 **NOTE**

Symbols and meanings of indicators on the S5700-28TP-LI-AC, the S5700-28X-LI-DC, the S5700-52X-LI-AC, and the S5700-52X-LI-DC are the same as those on the S5700-28X-LI-AC.

Figure 2-3 Indicators on the S5700-28X-LI-AC

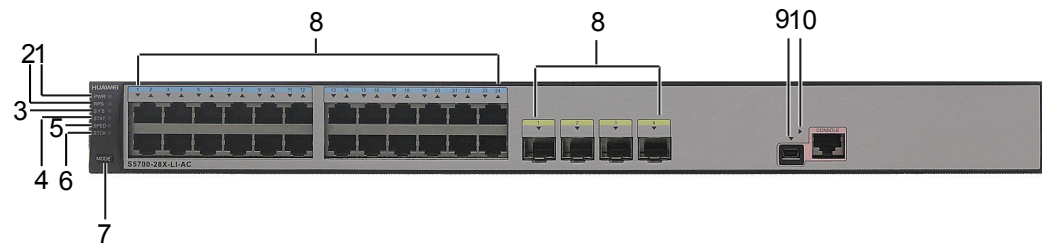

Table 2-6 Description of indicators on the S5700-28X-LI-AC

Number	Indicator/Button	Color	Description
1	PWR: power supply indicator	Off	The switch is powered off.
		Green	Steady on: The switch is powered on.
		Yellow	Steady on: The internal power module is faulty, and the switch is powered by the RPS system.
2	RPS: RPS power supply indicator	Off	No RPS is connected to the switch.

Number	Indicator/Button	Color	Description
		Green	<ul style="list-style-type: none"> ● Steady on: The RPS is in cold backup state or forced power-on state. ● Blinking: The RPS is providing power for another device.
		Yellow	<ul style="list-style-type: none"> ● Steady on: The RPS is in alarm state. ● Blinking: The RPS is providing power for the switch and the built-in power module of the switch is faulty.
3	SYS: system status indicator	Off	The system is not running.
		Green	<ul style="list-style-type: none"> ● Blinking once every 0.25s (4 Hz): The system is starting. ● Blinking once every 2s (0.5 Hz): The system is operating properly.
		Yellow	Blinking once every 2s (0.5 Hz): The system is sleeping.
		Red	Steady on: The system cannot start normally, or a temperature alarm or fan alarm is generated.
4	STAT: status indicator in STAT mode	Off	The STAT mode is not selected.
		Green	Steady on: The service port indicators are in the default mode (STAT).
5	SPED: status indicator in speed mode	Off	The SPED mode is not selected.
		Green	Steady on: The service port indicators indicate the port speed. After 45 seconds, the service port indicators automatically restore to STAT mode.
6	STCK: status indicator in stack mode	Off	The STCK mode is not selected.
		Green	<ul style="list-style-type: none"> ● Steady on: The service port indicators indicate the stack information. After 45 seconds, the service port indicators automatically restore to STAT mode. ● Blinking: The indicator indicates the active switch in a stack or a switch not in any stack.

Number	Indicator/ Button	Color	Description
7	MODE: mode switch button	-	<ul style="list-style-type: none"> When you press the button once, the SPED indicator turns green and the service port indicators show the speed of each port. When you press the button for a second time, the STCK indicator turns green and the service port indicators show the stack status. When you press the button for a third time, the STAT indicator turns green. <p>If you do not press the button within 45 seconds, the indicators restore to the default status. That is, the STAT indicator turns green, and the SPED and STCK indicators are off.</p>
8	Service port indicator <ul style="list-style-type: none"> GE electrical ports: The first indicator shows the status of the bottom left port. The indicators correspond to the ports from bottom to top and from left to right. 10GE optical port: Each optical port has a corresponding indicator above it. 	The meaning of the service port indicator varies with the current mode. For details, see Table 2-8 .	
9	Mini USB indicator	Off	The Mini USB port is not active, and the console port is active.
		Green	Steady on: The Mini USB port is active. When this LED is on, the console port LED is off.
10	Console indicator	Off	The console port is not active, and the Mini USB port is active.

Number	Indicator/Button	Color	Description
		Green	Steady on (default): The console port is active. When this LED is on, the Mini USB port LED is off.

S5700-28P-PWR-LI-AC

 **NOTE**

Symbols and meanings of indicators on the S5700-52P-PWR-LI-AC are the same as those on the S5700-28P-PWR-LI-AC.

Figure 2-4 Indicators on the S5700-28P-PWR-LI-AC



Table 2-7 Description of indicators on the S5700-28P-PWR-LI-AC

Number	Indicator/Button	Color	Description
1	PWR: power supply indicator	Off	The switch is powered off.
		Green	Steady on: The switch is powered on.
		Yellow	Steady on: The internal power module is faulty, and the switch is powered by the RPS system.
2	SYS: system status indicator	Off	The system is not running.
		Green	<ul style="list-style-type: none"> ● Blinking once every 0.25s (4 Hz): The system is starting. ● Blinking once every 2s (0.5 Hz): The system is operating properly.
		Red	Steady on: The system cannot start normally, or a temperature alarm or fan alarm is generated.

Number	Indicator/ Button	Color	Description
3	STAT: status indicator in STAT mode	Off	The STAT mode is not selected.
		Green	Steady on: The service port indicators are in the default mode (STAT).
4	SPED: status indicator in speed mode	Off	The SPED mode is not selected.
		Green	Steady on: The service port indicators indicate the port speed. After 45 seconds, the service port indicators automatically restore to STAT mode.
5	STCK: status indicator in stack mode	Off	The STCK mode is not selected.
		Green	<ul style="list-style-type: none"> ● Steady on: The service port indicators indicate the stack information. After 45 seconds, the service port indicators automatically restore to STAT mode. ● Blinking: The indicator indicates the active switch in a stack or a switch not in any stack.
6	PoE: PoE indicator	Off	The PoE mode is not selected.
		Green	Steady on: The service port indicators indicate the PoE status. After 45 seconds, the service port indicators automatically restore to STAT mode.
7	MODE: mode switch button	-	<ul style="list-style-type: none"> ● When you press the button once, the SPED indicator turns green and the service port indicators show the speed of each port. ● When you press the button for a second time, the STCK indicator turns green and the service port indicators show the stack status. ● When you press the button for a third time, the PoE indicator turns green and the service port indicators show the PoE status of each port. ● When you press the button for a fourth time, the STAT indicator turns green. <p>If you do not press the button within 45 seconds, the indicators restore to the default status. That is, the STAT indicator turns green, and the SPED, PoE, and STCK indicators are off.</p>

Number	Indicator/ Button	Color	Description
8	<p>Service port indicator</p> <ul style="list-style-type: none"> ● GE electrical ports: The first indicator shows the status of the bottom left port. The indicators correspond to the ports from bottom to top and from left to right. ● GE optical port: Each optical port has a corresponding indicator above it. 		The meaning of the service port indicator varies with the current mode. For details, see Table 2-8 .
9	Mini USB indicator	Off	The Mini USB port is not active, and the console port is active.
		Green	Steady on: The Mini USB port is active. When this LED is on, the console port LED is off.
10	Console indicator	Off	The console port is not active, and the Mini USB port is active.
		Green	Steady on (default): The console port is active. When this LED is on, the Mini USB port LED is off.

Table 2-8 Description of service port indicators in different modes

Display Mode	Color	Meaning
STAT mode	Off	The port is not connected or has been shut down.

Display Mode	Color	Meaning
	Green	<ul style="list-style-type: none"> ● Steady on: The port is connected. ● Blinking: The port is sending or receiving data.
SPED mode	Off	The port is not connected or has been shut down.
	Green	<ul style="list-style-type: none"> ● Steady on: <ul style="list-style-type: none"> 10M/100M/1000M port: The port is operating at a speed of 10/100 Mbit/s. 1000M/10GE port: The port is operating at a speed of 1000 Mbit/s. ● Blinking: <ul style="list-style-type: none"> 10M/100M/1000M port: The port is operating at a speed of 1000 Mbit/s. 1000M/10GE port: The port is operating at a speed of 10 Gbit/s.
PoE mode	Off	The port does not provide PoE power.
	Green	Steady on: The port is providing PoE power.
	Yellow	<ul style="list-style-type: none"> ● Steady on: The PoE function is disabled on the port. ● Blinking: A PoE fault has occurred. For example, an incompatible PD is connected to the port.
	Green and yellow	<p>Blinking green and yellow alternately: The port cannot provide power to a PD. The possible reasons including:</p> <ul style="list-style-type: none"> ● The power of a connected PD exceeds the port's power supply capability or upper power threshold. ● The power provided by the switch has reached the power supply capability of the switch. ● The switch is not enabled to provide power for PDs.
STCK mode	Off	Port indicators do not show the stack ID of the switch.

Display Mode	Color	Meaning
	Green	<ul style="list-style-type: none"> ● Steady on: <p>The switch is not a master switch:</p> <ul style="list-style-type: none"> - If the indicator of a port is steady on, the number of this port is the stack ID of the switch. - If the first nine port indicators of the switch are steady on, the stack ID of the switch is 0. ● Blinking: <p>The switch is a master switch:</p> <ul style="list-style-type: none"> - If the indicator of a port is blinking, the number of this port is the stack ID of the switch. - If the first nine port indicators of the switch are blinking, the stack ID of the switch is 0.

S5700-28X-PWR-LI-AC

 **NOTE**

Symbols and meanings of indicators on the S5700-52X-PWR-LI-AC, the S5700-28TP-PWR-LI-AC, and the S5701-28TP-PWR-LI-AC are the same as those on the S5700-28X-PWR-LI-AC.

Figure 2-5 Indicators on the S5700-28X-PWR-LI-AC

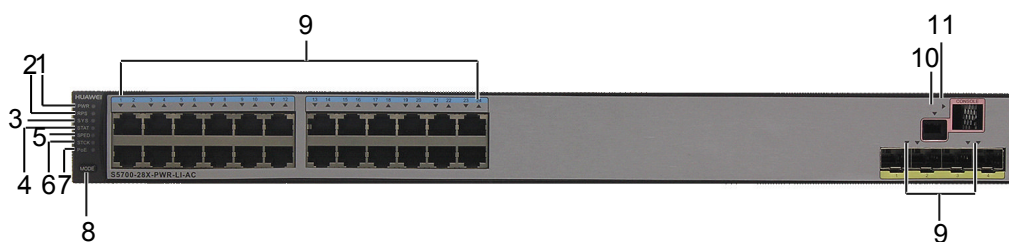

Table 2-9 Description of indicators on the S5700-28X-PWR-LI-AC

Number	Indicator/ Button	Color	Description
1	PWR: power supply indicator	Off	The switch is powered off.
		Green	Steady on: The switch is powered on.

Number	Indicator/ Button	Color	Description
		Yellow	Steady on: The internal power module is faulty, and the switch is powered by the RPS system.
2	RPS: RPS power supply indicator	Off	No RPS is connected to the switch.
		Green	<ul style="list-style-type: none"> ● Steady on: The RPS is in cold backup state or forced power-on state. ● Blinking: The RPS is providing power for another device.
		Yellow	<ul style="list-style-type: none"> ● Steady on: The RPS is in alarm state. ● Blinking: The RPS is providing power for the switch and the built-in power module of the switch is faulty.
3	SYS: system status indicator	Off	The system is not running.
		Green	<ul style="list-style-type: none"> ● Blinking once every 0.25s (4 Hz): The system is starting. ● Blinking once every 2s (0.5 Hz): The system is operating properly.
		Red	Steady on: The system cannot start normally, or a temperature alarm or fan alarm is generated.
4	STAT: status indicator in STAT mode	Off	The STAT mode is not selected.
		Green	Steady on: The service port indicators are in the default mode (STAT).
5	SPED: status indicator in speed mode	Off	The SPED mode is not selected.
		Green	Steady on: The service port indicators indicate the port speed. After 45 seconds, the service port indicators automatically restore to STAT mode.
6	STCK: status indicator in stack mode	Off	The STCK mode is not selected.
		Green	<ul style="list-style-type: none"> ● Steady on: The service port indicators indicate the stack information. After 45 seconds, the service port indicators automatically restore to STAT mode. ● Blinking: The indicator indicates the active switch in a stack or a switch not in any stack.
7	PoE: PoE indicator	Off	The PoE mode is not selected.

Number	Indicator/ Button	Color	Description
		Green	Steady on: The service port indicators indicate the PoE status. After 45 seconds, the service port indicators automatically restore to STAT mode.
8	MODE: mode switch button	-	<ul style="list-style-type: none"> ● When you press the button once, the SPED indicator turns green and the service port indicators show the speed of each port. ● When you press the button for a second time, the STCK indicator turns green and the service port indicators show the stack status. ● When you press the button for a third time, the PoE indicator turns green and the service port indicators show the PoE status of each port. ● When you press the button for a fourth time, the STAT indicator turns green. <p>If you do not press the button within 45 seconds, the indicators restore to the default status. That is, the STAT indicator turns green, and the SPED, PoE, and STCK indicators are off.</p>
9	Service port indicator <ul style="list-style-type: none"> ● GE electrical ports: The first indicator shows the status of the bottom left port. The indicators correspond to the ports from bottom to top and from left to right. ● 10GE optical port: Each optical port has a corresponding indicator above it. 		The meaning of the service port indicator varies with the current mode. For details, see Table 2-8 .

Number	Indicator/ Button	Color	Description
10	Mini USB indicator	Off	The Mini USB port is not active, and the console port is active.
		Green	Steady on: The Mini USB port is active. When this LED is on, the console port LED is off.
11	Console indicator	Off	The console port is not active, and the Mini USB port is active.
		Green	Steady on (default): The console port is active. When this LED is on, the Mini USB port LED is off.

S5700-10P-PWR-LI-AC

Figure 2-6 Indicators on the S5700-10P-PWR-LI-AC

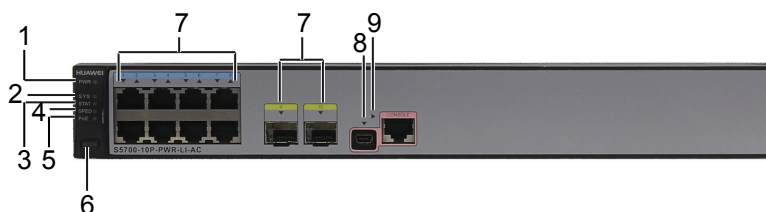

Table 2-10 Description of indicators on the S5700-10P-PWR-LI-AC

Number	Indicator/ Button	Color	Description
1	PWR: power supply indicator	Off	The switch is powered off.
		Green	Steady on: The switch is powered on.
		Yellow	Steady on: The PoE power is faulty.
2	SYS: system status indicator	Off	The system is not running.
		Green	<ul style="list-style-type: none"> Blinking once every 0.25s (4 Hz): The system is starting. Blinking once every 2s (0.5 Hz): The system is operating properly.

Number	Indicator/ Button	Color	Description
		Red	Steady on: The system cannot start normally, or a temperature alarm is generated.
3	STAT: status indicator in STAT mode	Off	The STAT mode is not selected.
		Green	Steady on: The service port indicators are in the default mode (STAT).
4	SPED: status indicator in speed mode	Off	The SPED mode is not selected.
		Green	Steady on: The service port indicators indicate the port speed. After 45 seconds, the service port indicators automatically restore to STAT mode.
5	PoE: PoE indicator	Off	The PoE mode is not selected.
		Green	Steady on: The service port indicators indicate the PoE status. After 45 seconds, the service port indicators automatically restore to STAT mode.
6	MODE: mode switch button	-	<ul style="list-style-type: none">● When you press the button once, the SPED indicator turns green and the service port indicators show the speed of each port.● When you press the button for a second time, the PoE indicator turns green and the service port indicators show the PoE status of each port.● When you press the button for a third time, the STAT indicator turns green. If you do not press the button within 45 seconds, the indicators restore to the default status. That is, the STAT indicator turns green, and the SPED and PoE indicators are off.

Number	Indicator/ Button	Color	Description
7	Service port indicator <ul style="list-style-type: none"> ● GE electrical ports: The first indicator shows the status of the bottom left port. The indicators correspond to the ports from bottom to top and from left to right. ● GE optical port: Each optical port has a corresponding indicator above it. 		The meaning of the service port indicator varies with the current mode. For details, see Table 2-8 .
8	Mini USB indicator	Off	The Mini USB port is not active, and the console port is active.
		Green	Steady on: The Mini USB port is active. When this LED is on, the console port LED is off.
9	Console indicator	Off	The console port is not active, and the Mini USB port is active.
		Green	Steady on (default): The console port is active. When this LED is on, the Mini USB port LED is off.

S5700-10P-LI-AC

Figure 2-7 Indicators on the S5700-10P-LI-AC

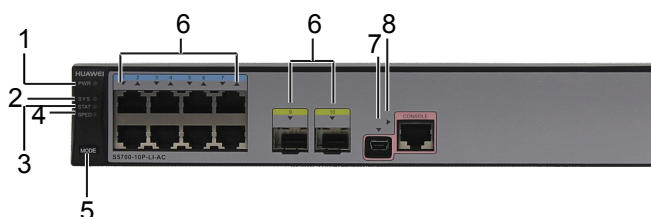

Table 2-11 Description of indicators on the S5700-10P-LI-AC

Number	Indicator/ Button	Color	Description
1	PWR: power supply indicator	Off	The switch is powered off.
		Green	Steady on: The switch is powered on.
2	SYS: system status indicator	Off	The system is not running.
		Green	<ul style="list-style-type: none">● Blinking once every 0.25s (4 Hz): The system is starting.● Blinking once every 2s (0.5 Hz): The system is operating properly.
		Red	Steady on: The system cannot start normally, or a temperature alarm is generated.
3	STAT: status indicator in STAT mode	Off	The STAT mode is not selected.
		Green	Steady on: The service port indicators are in the default mode (STAT).
4	SPED: status indicator in speed mode	Off	The SPED mode is not selected.
		Green	Steady on: The service port indicators indicate the port speed. After 45 seconds, the service port indicators automatically restore to STAT mode.
5	MODE: mode switch button	-	<ul style="list-style-type: none">● When you press the button once, the SPED indicator turns green and the service port indicators show the speed of each port.● When you press the button for a second time, the STAT indicator turns green. If you do not press the button within 45 seconds, the indicators restore to the default status. That is, the STAT indicator turns green, and the SPED indicator is off.

Number	Indicator/ Button	Color	Description
6	Service port indicator <ul style="list-style-type: none"> ● GE electrical ports: The first indicator shows the status of the bottom left port. The indicators correspond to the ports from bottom to top and from left to right. ● GE optical port: Each optical port has a corresponding indicator above it. 		The meaning of the service port indicator varies with the current mode. For details, see Table 2-8 .
7	Mini USB indicator	Off	The Mini USB port is not active, and the console port is active.
		Green	Steady on: The Mini USB port is active. When this LED is on, the console port LED is off.
8	Console indicator	Off	The console port is not active, and the Mini USB port is active.
		Green	Steady on (default): The console port is active. When this LED is on, the Mini USB port LED is off.

2.3.4 Port Description

10/100/1000BASE-T Ethernet Electrical Port

A 10/100/1000BASE-T Ethernet electrical port receives and sends services at a speed of 10/100/1000 Mbit/s. The ports must use [network cables](#). [Table 2-12](#) describes the attributes of a 10/100/1000BASE-T Ethernet electrical port.

Table 2-12 Attributes of a 10/100/1000BASE-T Ethernet electrical port

Attribute	Description
Connector type	RJ45
Standards compliance	IEEE802.3, IEEE802.3u, IEEE802.3ab
Electrical port	MDI/MDIX NOTE <ul style="list-style-type: none"> ● A medium dependent interface (MDI) describes the interface (both physical and electrical) in a computer network from a physical layer implementation to the physical medium used to carry the transmission. The Ethernet ports of most NICs are MDIs. ● An MDIX (for MDI crossover) is a version of MDI that enables connection between like devices. MDIX ports are usually used on hubs or LAN switches.
Frame format	Ethernet_II, Ethernet_SAP, Ethernet_SNAP
Network protocol	IP
Working mode	10/100/1000 Mbit/s auto-sensing Full duplex
Maximum transmission distance	100 m

1000BASE-X Ethernet Optical Port

A 1000BASE-X Ethernet optical port receives and sends services at a speed of 1000 Mbit/s.

Table 2-13 describes the attributes of a 1000BASE-X Ethernet optical port.

Table 2-13 Attributes of a 1000BASE-X Ethernet optical port

Attribute	Description
Connector type	LC/PC
Optical port attribute	Depending on the optical module used on the port (see SFP/eSFP Modules)
Standards compliance	IEEE802.3z
Frame format	Ethernet_II, Ethernet_SAP, Ethernet_SNAP
Network protocol	IP
Working mode	1000 Mbit/s Full duplex

Console Port

The console port is connected to a console for on-site configuration. The port must use a [console cable](#). The console port is used when a switch is powered on for the first time. For details about the attributes of a console port, see [Table 2-14](#).

Table 2-14 Attributes of a console port

Attribute	Description
Connector type	RJ45
Standards compliance	RS-232
Working mode	Duplex Universal Asynchronous Receiver/Transmitter (UART)
Baud rate	9600 bit/s to 115200 bit/s Default value: 9600 bit/s
Data equipment type	Data circuit-terminating equipment (DCE)

Mini USB Port

The Mini USB port can connect to a console for onsite configuration of the system. The Mini USB port and console port cannot be used together. Select one as required. The Mini USB port is recommended.

10GE SFP+ Ethernet Optical Port

A 10GE SFP+ Ethernet optical port supports auto-sensing to 1000 Mbit/s. It receives and sends services at a speed of 1000 Mbit/s or 10 Gbit/s. [Table 2-15](#) describes the attributes of a 10GE SFP+ Ethernet optical port.

Table 2-15 Attributes of a 10GE SFP+ Ethernet optical port

Attribute	Description
Connector type	LC/PC
Optical port attribute	Depending on the optical module used on the port (see SFP+ Modules)
Standards compliance	IEEE802.3ae
Frame format	Ethernet_II, Ethernet_SAP, Ethernet_SNAP
Network protocol	IP
Working mode	GE/10GE auto-sensing Full duplex

Combo Port

A combo port consists of an optical Ethernet port and an electrical Ethernet port on the panel. Each combo port matches only one internal forwarding port. A combo port is a multiplexing port, and you can use either the optical port or electrical port at one time. When one of the Ethernet ports is used, the other port is disabled.

NOTE

By default, a combo port works in the auto mode. In the auto mode, if the electrical port is connected to a network cable first, the combo port works as an electrical port to transmit data; if the optical port is connected to a fiber first, the combo port works as an optical port to transmit data. When both optical port and electrical port are connected, the optical port takes the priority. You can run the **combo-port** command to set the working mode of the combo port.

2.3.5 Power Supply

PoE Power Supply Configuration

Currently, the S5700LI series have built-in PoE power modules. The S5700LI series contain S5700-10P-PWR-LI-AC, S5700-28P-PWR-LI-AC, S5700-52P-PWR-LI-AC, S5700-28X-PWR-LI-AC, S5700-28TP-PWR-LI-AC, S5701-28TP-PWR-LI-AC, and S5700-52X-PWR-LI-AC. Each port provides a maximum of 30 W power and supports a maximum of 100 m power supply distance.

The S5700-10P-PWR-LI-AC has a built-in power module and cannot connect to the RPS. The built-in power module provides 130 W PoE power. The switch supports a maximum of eight ports in compliance with 802.3af or a maximum of four ports in compliance with 802.3at.

The S5700-28P-PWR-LI-AC, S5700-52P-PWR-LI-AC, S5700-28TP-PWR-LI-AC, S5701-28TP-PWR-LI-AC, S5700-28X-PWR-LI-AC, and S5700-52X-PWR-LI-AC have a built-in PoE power module and can connect to the RPS1800. The power supply configurations are shown in [Table 2-16](#).

Table 2-16 Power supply configurations

Power Module	PoE Power	Device	Maximum Number of Ports (Fully Loaded)
Not connected to an RPS	370 W	S5700-28P-PWR-LI-AC S5700-52P-PWR-LI-AC S5700-28X-PWR-LI-AC S5700-52X-PWR-LI-AC S5700-28TP-PWR-LI-AC	<ul style="list-style-type: none"> ● 802.3af (15.4 W per port): 24 ● 802.3at (30 W per port): 12
	185 W	S5701-28TP-PWR-LI-AC	<ul style="list-style-type: none"> ● 802.3af (15.4 W per port): 12 ● 802.3at (30 W per port): 6

Power Module	PoE Power	Device	Maximum Number of Ports (Fully Loaded)
Connected to an RPS	800 W	S5700-28P-PWR-LI-AC S5700-28TP-PWR-LI-AC S5700-28X-PWR-LI-AC	<ul style="list-style-type: none"> ● 802.3af (15.4 W per port): 24 ● 802.3at (30 W per port): 24
		S5700-52P-PWR-LI-AC S5700-52X-PWR-LI-AC	<ul style="list-style-type: none"> ● 802.3af (15.4 W per port): 48 ● 802.3at (30 W per port): 26
		S5701-28TP-PWR-LI-AC	<ul style="list-style-type: none"> ● 802.3af (15.4 W per port): 12 ● 802.3at (30 W per port): 12

Figure 2-8 shows the power supply mode of a single PoE AC power module.

Figure 2-8 Power supply mode of a single PoE AC power module

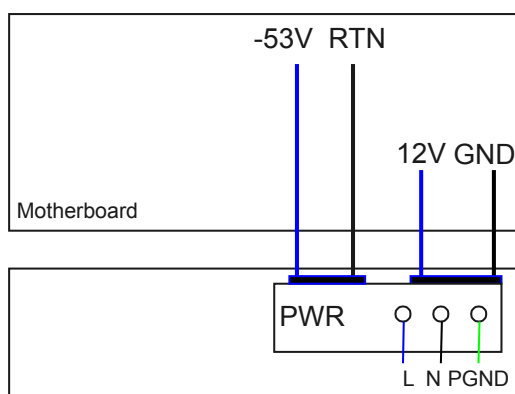

L: Live wire N: Neutral wire PGND: Protective ground GND: 12 V reference ground RTN: -53 V reference ground

The S5700-10P-PWR-LI-AC, S5700-28P-PWR-LI-AC, S5700-52P-PWR-LI-AC, S5700-28X-PWR-LI-AC, S5700-28TP-PWR-LI-AC, S5701-28TP-PWR-LI-AC, and S5700-52X-PWR-LI-AC have built-in PoE power modules, which provide a channel of 12 V voltage and a channel of -53 V voltage. The 12 V voltage is provided for the entire device, and the -53 V voltage is provided for the PDs.

Non-PoE Power Supply Configuration

The S5700-LI series non-PoE switches have a single built-in power module and do not support pluggable power modules.

All S5700-LI series non-PoE switches except the S5700-10P-LI-AC can connect to the RPS1800.

Figure 2-9 shows the power supply mode of a single non-PoE DC power module. After DC power is transmitted to the PWR module on the switch, the PWR module provides 12 V output voltage for the entire device.

Figure 2-9 Power supply mode of a single DC power module

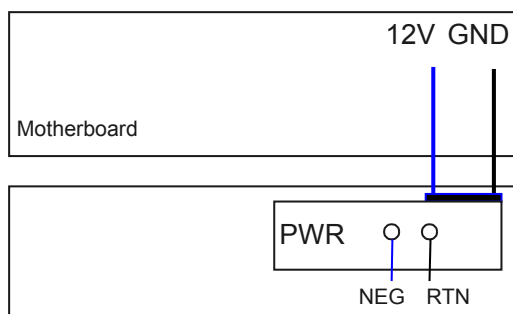

NEG: Power cable

RTN: Power return cable

GND: 12 V reference ground

Figure 2-10 shows the power supply mode of a single non-PoE AC power module. After AC power is transmitted to the PWR module on the switch, the PWR module provides 12 V output voltage for the entire device.

Figure 2-10 Power supply mode of a single non-PoE AC power module

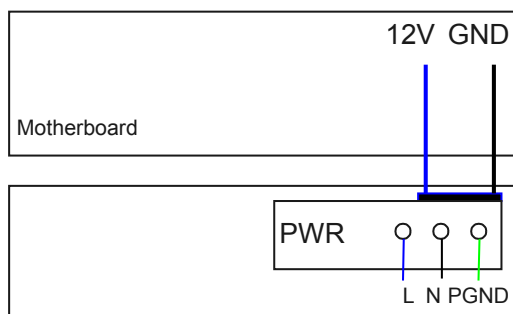

L: Live wire

N: Neutral wire

PGND: Protective ground wire

GND: 12 V reference ground

2.3.6 Heat Dissipation

The S5700 can use the following heat dissipation modes:

- Natural heat dissipation (without fans)
- Intelligent heat dissipation
- Forcible heat dissipation

 **NOTE**

The fans can work in the intelligent mode or forcible mode.

- In the intelligent mode, the fans start to operate only when the ambient temperature goes higher than a specified value.
- In the forcible mode, the fans operate immediately when the switch starts.

Table 2-17 shows the heat dissipation modes of the S5700-LI.

Table 2-17 S5700-LI heat dissipation modes

Heat Dissipation Mode	Model	Air Flow in the Chassis
Natural heat dissipation	<ul style="list-style-type: none"> ● S5700-28P-LI-AC ● S5700-28P-LI-DC ● S5700-28TP-LI-AC ● S5700-10P-PWR-LI-AC ● S5700-10P-LI-AC 	-

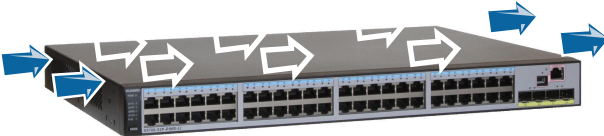
Heat Dissipation Mode	Model	Air Flow in the Chassis
Forcible heat dissipation	<ul style="list-style-type: none"> ● S5700-52P-LI-AC ● S5700-52P-LI-DC ● S5700-28P-PWR-LI-AC ● S5700-52P-PWR-LI-AC ● S5700-28TP-PWR-LI-AC ● S5701-28TP-PWR-LI-AC ● S5700-28X-LI-AC ● S5700-28X-LI-DC ● S5700-52X-LI-AC ● S5700-52X-LI-DC ● S5700-28X-PWR-LI-AC ● S5700-52X-PWR-LI-AC 	<p>The air flows in from the left and flows out from the right.</p> 

2.3.7 Specifications

Table 2-18 lists specifications of the S5700-LI.

Table 2-18 Specifications of the S5700-LI

Item	Description
Packet forwarding capacity Switching capacity	<ul style="list-style-type: none"> ● S5700-28P-LI-AC: 42 Mpps, 128 Gbit/s ● S5700-28P-LI-DC: 42 Mpps, 128 Gbit/s ● S5700-52P-LI-AC: 78 Mpps, 256 Gbit/s ● S5700-52P-LI-DC: 78 Mpps, 256 Gbit/s ● S5700-28P-PWR-LI-AC: 42 Mpps, 128 Gbit/s ● S5700-52P-PWR-LI-AC: 78 Mpps, 256 Gbit/s ● S5700-28TP-LI-AC: 42 Mpps, 128 Gbit/s ● S5700-28TP-PWR-LI-AC: 42 Mpps, 128 Gbit/s ● S5701-28TP-PWR-LI-AC: 42 Mpps, 128 Gbit/s ● S5700-28X-LI-AC: 96 Mpps, 128 Gbit/s ● S5700-28X-LI-DC: 96 Mpps, 128 Gbit/s ● S5700-52X-LI-AC: 132 Mpps, 256 Gbit/s ● S5700-52X-LI-DC: 132 Mpps, 256 Gbit/s ● S5700-28X-PWR-LI-AC: 96 Mpps, 128 Gbit/s ● S5700-52X-PWR-LI-AC: 132 Mpps, 256 Gbit/s ● S5700-10P-PWR-LI-AC: 15 Mpps, 26 Gbit/s ● S5700-10P-LI-AC: 15 Mpps, 26 Gbit/s
DDR memory	256 MB
Flash memory	200 MB
Mean time between failures (MTBF)	<ul style="list-style-type: none"> ● S5700-28P-LI-AC: 49.69 years ● S5700-28P-LI-DC: 49.69 years ● S5700-52P-LI-AC: 39.26 years ● S5700-52P-LI-DC: 39.26 years ● S5700-28P-PWR-LI-AC: 44.24 years ● S5700-52P-PWR-LI-AC: 35.70 years ● S5700-28TP-LI-AC: 49.69 years ● S5700-28TP-PWR-LI-AC: 44.24 years ● S5701-28TP-PWR-LI-AC: 44.24 years ● S5700-28X-LI-AC: 68.95 years ● S5700-28X-LI-DC: 68.95 years ● S5700-52X-LI-AC: 61.86 years ● S5700-52X-LI-DC: 61.86 years ● S5700-28X-PWR-LI-AC: 61.53 years ● S5700-52X-PWR-LI-AC: 40.72 years ● S5700-10P-PWR-LI-AC: 36.89 years ● S5700-10P-LI-AC: 44.41 years

Item		Description
Mean time to repair (MTTR)		2 hours
Availability		> 0.99999
Surge protection	Service port protection	Common mode: ± 6 kV
	Power supply protection	<ul style="list-style-type: none"> ● DC: ± 1 kV in differential mode; ± 2 kV in common mode ● AC: <ul style="list-style-type: none"> - S5700-28P-LI-AC: ± 2 kV in differential mode; ± 4 kV in common mode - Others: ± 6 kV in differential mode; ± 6 kV in common mode
Dimensions (W x D x H)		<ul style="list-style-type: none"> ● S5700-28P-LI-AC: 442.0 mm x 220.0 mm x 43.6 mm ● S5700-28P-LI-DC: 442.0 mm x 220.0 mm x 43.6 mm ● S5700-52P-LI-AC: 442.0 mm x 310.0 mm x 43.6 mm ● S5700-52P-LI-DC: 442.0 mm x 310.0 mm x 43.6 mm ● S5700-28P-PWR-LI-AC: 442.0 mm x 310.0 mm x 43.6 mm ● S5700-52P-PWR-LI-AC: 442.0 mm x 310.0 mm x 43.6 mm ● S5700-28TP-LI-AC: 442.0 mm x 220.0 mm x 43.6 mm ● S5700-28TP-PWR-LI-AC: 442.0 mm x 310.0 mm x 43.6 mm ● S5701-28TP-PWR-LI-AC: 442.0 mm x 310.0 mm x 43.6 mm ● S5700-28X-LI-AC: 442.0 mm x 220.0 mm x 43.6 mm ● S5700-28X-LI-DC: 442.0 mm x 220.0 mm x 43.6 mm ● S5700-52X-LI-AC: 442.0 mm x 310.0 mm x 43.6 mm ● S5700-52X-LI-DC: 442.0 mm x 310.0 mm x 43.6 mm ● S5700-28X-PWR-LI-AC: 442.0 mm x 310.0 mm x 43.6 mm ● S5700-52X-PWR-LI-AC: 442.0 mm x 310.0 mm x 43.6 mm ● S5700-10P-PWR-LI-AC: 320.0 mm x 220.0 mm x 43.6 mm ● S5700-10P-LI-AC: 250.0 mm x 180.0 mm x 43.6 mm
Weight		≤ 5 kg
Stack port		<p>Four uplink 1000Base-X optical service ports, two uplink 1000Base-X optical service ports, or four uplink 10GE SFP+ optical service ports are used as stack ports.</p> <p>NOTE The S5700-10P-PWR-LI-AC and S5700-10P-LI-AC do not support stacking.</p>
RPS		All S5700-LI series except the S5700-10P-PWR-LI-AC and S5700-10P-LI-AC support the RPS.
PoE		The PWR series support PoE.

Item		Description
Input DC voltage	Rated input voltage range	-48 V DC to -60 V DC
	Maximum voltage range	-36 V DC to -72 V DC
Input AC voltage	Rated input voltage range	100 V AC to 240 V AC; 50/60 Hz
	Maximum voltage range	90 V AC to 264 V AC; 47 Hz to 63 Hz
Maximum power consumption (100% throughput, 100% PoE loads, full speed of fans)		<ul style="list-style-type: none"> ● S5700-28P-LI-AC: 24 W ● S5700-28P-LI-DC: 24 W ● S5700-52P-LI-AC: 48.4 W ● S5700-52P-LI-DC: 48.3 W ● S5700-28P-PWR-LI-AC: 436.5 W (power consumption: 66.5 W, PoE: 370 W) ● S5700-52P-PWR-LI-AC: 464.5 W (power consumption: 94.5 W, PoE: 370 W) ● S5700-28TP-LI-AC: 24 W ● S5700-28TP-PWR-LI-AC: 436.5 W (power consumption: 66.5 W, PoE: 370 W) ● S5701-28TP-PWR-LI-AC: 250 W (power consumption: 65 W, PoE: 185 W) ● S5700-28X-LI-AC: 41 W ● S5700-28X-LI-DC: 42 W ● S5700-52X-LI-AC: 61 W ● S5700-52X-LI-DC: 60 W ● S5700-28X-PWR-LI-AC: 448.8 W (power consumption: 78.8 W, PoE: 370 W) ● S5700-52X-PWR-LI-AC: 479.3 W (power consumption: 109.3 W, PoE: 370 W) ● S5700-10P-PWR-LI-AC: 142.4 W (power consumption: 18.4 W, PoE: 124 W) ● S5700-10P-LI-AC: 11.5 W

Item		Description
Temperature	Operating temperature	<p>The operating temperature of the S5700-10P-PWR-LI-AC and S5700-10P-LI-AC is 0°C to +45°C at an altitude between 0 m and 1800 m. The operating temperature of the other S5700-LI series is 0°C to +50°C at an altitude between 0 m and 1800 m.</p> <p>NOTE When the altitude is between 1800 m and 5000 m, the operating temperature reduces 1°C every time the altitude increases 220 m.</p>
	Storage temperature	-40°C to +70°C
Noise under normal temperature (23°C, Sound Power)		<ul style="list-style-type: none"> ● S5700-28P-LI-AC: 0 (The device has no fans.) ● S5700-28P-LI-DC: 0 (The device has no fans.) ● S5700-52P-LI-AC: less than 43.8 dBA ● S5700-52P-LI-DC: less than 43.8 dBA ● S5700-28P-PWR-LI-AC: less than 49.2 dBA ● S5700-52P-PWR-LI-AC: less than 49.2 dBA ● S5700-28TP-LI-AC: 0 (The device has no fans.) ● S5700-28TP-PWR-LI-AC: less than 49.2 dBA ● S5701-28TP-PWR-LI-AC: less than 49.2 dBA ● S5700-28X-LI-AC: less than 44.9 dBA ● S5700-28X-LI-DC: less than 44.9 dBA ● S5700-52X-LI-AC: less than 47.9 dBA ● S5700-52X-LI-DC: less than 47.9 dBA ● S5700-28X-PWR-LI-AC: less than 49.5 dBA ● S5700-52X-PWR-LI-AC: less than 50.2 dBA ● S5700-10P-PWR-LI-AC: 0 (The device has no fans.) ● S5700-10P-LI-AC: 0 (The device has no fans.)
Relative humidity		5% RH to 95% RH, non-condensing
Operating altitude		<ul style="list-style-type: none"> ● S5700-28P-LI-AC, S5700-28P-LI-DC, S5700-28TP-LI-AC: 0 m to 3000 m ● S5700-52P-LI-DC, S5700-28X-LI-DC, S5700-52X-LI-DC: 0 m to 2000 m ● S5700-52P-LI-AC, S5700-28P-PWR-LI-AC, S5700-28TP-PWR-LI-AC, S5701-28TP-PWR-LI-AC, S5700-52P-PWR-LI-AC, S5700-28X-PWR-LI-AC, S5700-52X-PWR-LI-AC, S5700-28X-LI-AC: 0 m to 4000 m ● S5700-52X-LI-AC, S5700-10P-PWR-LI-AC, S5700-10P-LI-AC: 0 m to 5000 m

Item	Description
EMC	<ul style="list-style-type: none"> ● CISPR22 Class A ● CISPR24 ● EN55022 Class A ● EN50024 ● ETSI EN 300 386 Class A ● CFR 47 FCC Part 15 Class A ● ICES 003 Class A ● AS/NZS CISPR22 Class A ● IEC61000-4-2 ● ITU-T K 20 ● ITU-T K 44
Environmental standard	<ul style="list-style-type: none"> ● RoHS ● REACH
Security	<ul style="list-style-type: none"> ● IEC 60950-1 ● EN 60950-1/A11/A12 ● UL 60950-1 ● CSA C22.2 No 60950-1 ● AS/NZS 60950.1
Laser safety	<ul style="list-style-type: none"> ● IEC60825-1 ● IEC60825-2 ● EN60825-1 ● EN60825-2

2.4 S5700S-LI

2.4.1 Version Mapping

Table 2-19 lists the mapping between the S5700S-LI chassis and software versions.

Table 2-19 Mapping between the S5700S-LI chassis and software versions



Series	Model	Available Version
S5700S-LI	S5700S-28P-LI-AC	V200R001C00 and later versions
	S5700S-52P-LI-AC	V200R001C00 and later versions

2.4.2 Appearance and Structure

Front View

Table 2-20 shows the front view of the S5700S-LI chassis.

Table 2-20 Front view of the S5700S-LI chassis

Model	Image
S5700S-28P-LI-AC	
S5700S-52P-LI-AC	

1. Twenty-four 10/100/1000BASE-T Ethernet electrical ports	2. Forty-eight 10/100/1000BASE-T Ethernet electrical ports	3. Four 1000BASE-X Ethernet optical ports	4. One console port
5. One Mini USB port	-	-	-

Rear View

Table 2-21 shows the rear view of the S5700S-LI chassis.

Table 2-21 Rear view of the S5700S-LI chassis

Model	Image
S5700S-28P-LI-AC	

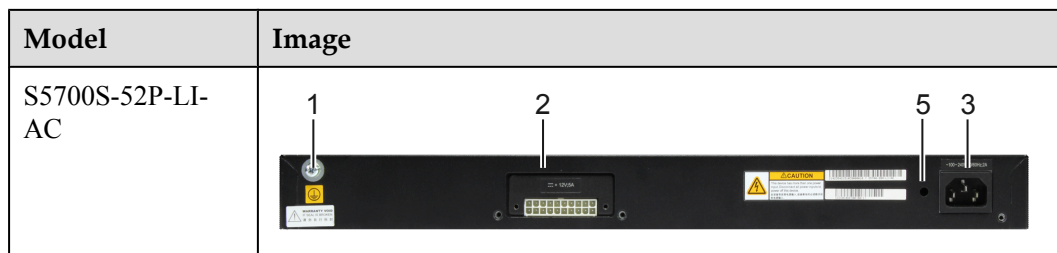

1. Ground screw NOTE It is used with a ground cable .	2. RPS socket NOTE It is used with an RPS cable which is not hot swappable.	3. AC socket NOTE It is used with an AC power cable .	-
---	---	---	---

2.4.3 Indicator Description

S5700S-28P-LI-AC

NOTE

Symbols and meanings of indicators on the S5700S-52P-LI-AC are the same as those on the S5700S-28P-LI-AC.

Figure 2-11 Indicators on the S5700S-28P-LI-AC

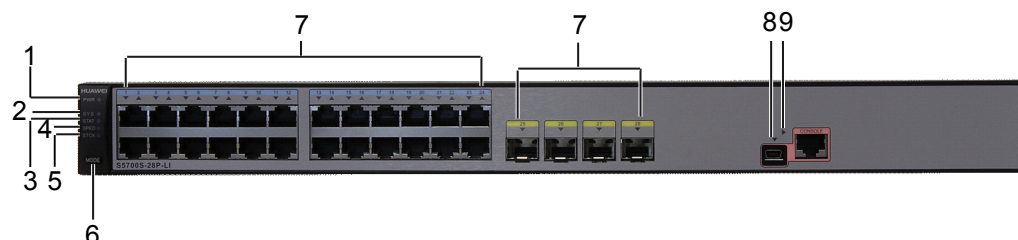

Table 2-22 Description of indicators on the S5700S-28P-LI-AC

Number	Indicator/ Button	Color	Description
1	PWR: power supply indicator	Off	The switch is powered off.
		Green	Steady on: The switch is powered on.
		Yellow	Steady on: The internal power module is faulty, and the switch is powered by the RPS system.

Number	Indicator/ Button	Color	Description
2	SYS: system status indicator	Off	The system is not running.
		Green	<ul style="list-style-type: none"> ● Blinking once every 0.25s (4 Hz): The system is starting. ● Blinking once every 2s (0.5 Hz): The system is operating properly.
		Yellow	Blinking once every 2s (0.5 Hz): The system is sleeping. NOTE The system can wake from the sleeping state if you press the MODE button.
		Red	Steady on: The system cannot start normally, or a temperature alarm or fan alarm is generated.
3	STAT: status indicator in STAT mode	Off	The STAT mode is not selected.
		Green	Steady on: The service port indicators are in the default mode (STAT).
4	SPED: status indicator in speed mode	Off	The SPED mode is not selected.
		Green	Steady on: The service port indicators indicate the port speed. After 45 seconds, the service port indicators automatically restore to STAT mode.
5	STCK: status indicator in stack mode	-	Currently, the S5700S-LI does not support stacking. This indicator is reserved for the stacking function.
6	MODE: mode switch button	-	<ul style="list-style-type: none"> ● When you press the button once, the SPED indicator turns green and the service port indicators show the speed of each port. ● When you press the button for a second time, the STAT indicator turns green. If you do not press the button within 45 seconds, the indicators restore to the default status. That is, the STAT indicator turns green, and the SPED and STCK indicators are off.

Number	Indicator/ Button	Color	Description
7	Service port indicator <ul style="list-style-type: none"> ● GE electrical ports: The first indicator shows the status of the bottom left port. The indicators correspond to the ports from bottom to top and from left to right. ● GE optical port: Each optical port has a corresponding indicator above it. 		The meaning of the service port indicator varies with the current mode. For details, see Table 2-23 .
8	Mini USB indicator	Off	The Mini USB port is not active, and the console port is active.
		Green	Steady on: The Mini USB port is active. When this LED is on, the console port LED is off.
9	Console indicator	Off	The console port is not active, and the Mini USB port is active.
		Green	Steady on (default): The console port is active. When this LED is on, the Mini USB port LED is off.

Table 2-23 Description of service port indicators in different modes

Display Mode	Color	Meaning
STAT mode	Off	The port is not connected or has been shut down.

Display Mode	Color	Meaning
	Green	<ul style="list-style-type: none"> ● Steady on: The port is connected. ● Blinking: The port is sending or receiving data.
SPED mode	Off	The port is not connected or has been shut down.
	Green	<ul style="list-style-type: none"> ● Steady on: <ul style="list-style-type: none"> 10M/100M/1000M port: The port is operating at a speed of 10/100 Mbit/s. 1000M/10GE port: The port is operating at a speed of 1000 Mbit/s. ● Blinking: <ul style="list-style-type: none"> 10M/100M/1000M port: The port is operating at a speed of 1000 Mbit/s. 1000M/10GE port: The port is operating at a speed of 10 Gbit/s.

2.4.4 Port Description

10/100/1000BASE-T Ethernet Electrical Port

A 10/100/1000BASE-T Ethernet electrical port receives and sends services at a speed of 10/100/1000 Mbit/s. The ports must use **network cables**. [Table 2-24](#) describes the attributes of a 10/100/1000BASE-T Ethernet electrical port.

Table 2-24 Attributes of a 10/100/1000BASE-T Ethernet electrical port

Attribute	Description
Connector type	RJ45
Standards compliance	IEEE802.3, IEEE802.3u, IEEE802.3ab
Electrical port	MDI/MDIX NOTE <ul style="list-style-type: none"> ● A medium dependent interface (MDI) describes the interface (both physical and electrical) in a computer network from a physical layer implementation to the physical medium used to carry the transmission. The Ethernet ports of most NICs are MDIs. ● An MDIX (for MDI crossover) is a version of MDI that enables connection between like devices. MDIX ports are usually used on hubs or LAN switches.
Frame format	Ethernet_II, Ethernet_SAP, Ethernet_SNAP
Network protocol	IP

Attribute	Description
Working mode	10/100/1000 Mbit/s auto-sensing Full duplex
Maximum transmission distance	100 m

1000BASE-X Ethernet Optical Port

A 1000BASE-X Ethernet optical port receives and sends services at a speed of 1000 Mbit/s. [Table 2-25](#) describes the attributes of a 1000BASE-X Ethernet optical port.

Table 2-25 Attributes of a 1000BASE-X Ethernet optical port

Attribute	Description
Connector type	LC/PC
Optical port attribute	Depending on the optical module used on the port (see SFP/eSFP Modules)
Standards compliance	IEEE802.3z
Frame format	Ethernet_II, Ethernet_SAP, Ethernet_SNAP
Network protocol	IP
Working mode	1000 Mbit/s Full duplex

Console Port

The console port is connected to a console for on-site configuration. The port must use a [console cable](#). The console port is used when a switch is powered on for the first time. For details about the attributes of a console port, see [Table 2-26](#).

Table 2-26 Attributes of a console port

Attribute	Description
Connector type	RJ45
Standards compliance	RS-232
Working mode	Duplex Universal Asynchronous Receiver/Transmitter (UART)

Attribute	Description
Baud rate	9600 bit/s to 115200 bit/s Default value: 9600 bit/s
Data equipment type	Data circuit-terminating equipment (DCE)

Mini USB Port

The Mini USB port can connect to a console for onsite configuration of the system. The Mini USB port and console port cannot be used together. Select one as required. The Mini USB port is recommended.

2.4.5 Power Supply

Power Supply Configuration

The S5700S-LI has a single built-in AC power module and does not support pluggable power modules.

The S5700S-LI can connect to the RPS1800.

Figure 2-12 shows the power supply mode of a single non-PoE AC power module. After AC power is transmitted to the PWR module on the switch, the PWR module provides 12 V output voltage for the entire device.

Figure 2-12 Power supply mode of a single non-PoE AC power module

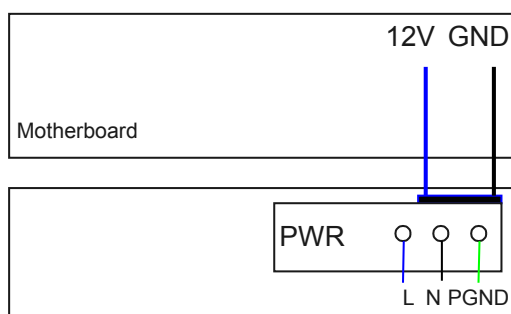

L: Live wire N: Neutral wire PGND: Protective ground wire GND: 12 V reference ground

2.4.6 Heat Dissipation

Table 2-27 shows the heat dissipation modes of the S5700S-LI.

Table 2-27 S5700S-LI heat dissipation modes

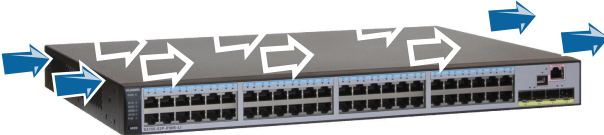
Heat Dissipation Mode	Model	Air Flow in the Chassis
Natural heat dissipation	S5700S-28P-LI-AC	-
Forcible heat dissipation	S5700S-52P-LI-AC	The air flows in from the left and flows out from the right. 

2.4.7 Specifications

Table 2-28 lists specifications of the S5700S-LI.

Table 2-28 Specifications of the S5700S-LI

Item	Description
CPU	1 GHz dominant frequency
Packet forwarding capacity Switching capacity	<ul style="list-style-type: none"> ● S5700S-28P-LI-AC: 42 Mpps, 128 Gbit/s ● S5700S-52P-LI-AC: 78 Mpps, 256 Gbit/s
DDR memory	256 MB
Flash memory	200 MB
Mean time between failures (MTBF)	<ul style="list-style-type: none"> ● S5700S-28P-LI-AC: 49.69 years ● S5700S-52P-LI-AC: 39.26 years
Mean time to repair (MTTR)	2 hours
Availability	> 0.99999

Item		Description
Surge protection	Service port protection	Common mode: ± 6 kV
	Power supply protection	<ul style="list-style-type: none"> ● S5700S-28P-LI-AC: ± 2 kV in differential mode; ± 4 kV in common mode ● S5700S-52P-LI-AC: ± 6 kV in differential mode; ± 6 kV in common mode
Dimensions (W x D x H)		<ul style="list-style-type: none"> ● S5700S-28P-LI-AC: 442.0 mm x 220.0 mm x 43.6 mm ● S5700S-52P-LI-AC: 442.0 mm x 310.0 mm x 43.6 mm
Weight		≤ 5 kg
Stack port		Not supported
RPS		Supported
PoE		Not supported
Input AC voltage	Rated input voltage range	100 V AC to 240 V AC; 50/60 Hz
	Maximum input voltage range	90 V AC to 264 V AC; 47 Hz to 63 Hz
Maximum power consumption (100% throughput, full speed of fans)		<ul style="list-style-type: none"> ● S5700S-28P-LI-AC: 24 W ● S5700S-52P-LI-AC: 48.4 W
Temperature	Operating temperature	0°C to +50°C (at 0 m to 1800 m altitude) NOTE When the altitude is between 1800 m and 4000 m, the operating temperature reduces 1°C every time the altitude increases 220 m.
	Storage temperature	-40°C to +70°C
Noise under normal temperature (23°C, Sound Power)		<ul style="list-style-type: none"> ● S5700S-28P-LI-AC: 0 (The device has no fans.) ● S5700S-52P-LI-AC: less than 43.8 dBA
Relative humidity		5% RH to 95% RH, non-condensing
Altitude		<ul style="list-style-type: none"> ● S5700S-28P-LI-AC: 0 m to 3000 m ● S5700S-52P-LI-AC: 0 m to 4000 m

Item	Description
EMC	<ul style="list-style-type: none"> ● CISPR22 Class A ● CISPR24 ● EN55022 Class A ● EN50024 ● ETSI EN 300 386 Class A ● CFR 47 FCC Part 15 Class A ● ICES 003 Class A ● AS/NZS CISPR22 Class A ● IEC61000-4-2 ● ITU-T K 20 ● ITU-T K 44
Environmental standard	<ul style="list-style-type: none"> ● RoHS ● REACH
Security	<ul style="list-style-type: none"> ● IEC 60950-1 ● EN 60950-1/A11/A12 ● UL 60950-1 ● CSA C22.2 No 60950-1 ● AS/NZS 60950.1
Laser safety	<ul style="list-style-type: none"> ● IEC60825-1 ● IEC60825-2 ● EN60825-1 ● EN60825-2

2.5 S5700-SI

2.5.1 Version Mapping

Table 2-29 lists the mapping between the S5700-SI chassis and software versions.

Table 2-29 Mapping between the S5700-SI chassis and software versions

Series	Model	Available Version
S5700-SI	S5700-28C-SI	V100R005C01 and later versions
	S5700-52C-SI	V100R005C01 and later versions

Series	Model	Available Version
	S5700-24TP-SI-AC	V100R005C01 and later versions
	S5700-24TP-SI-DC	V100R005C01 and later versions
	S5700-48TP-SI-AC	V100R005C01 and later versions
	S5700-48TP-SI-DC	V100R005C01 and later versions
	S5700-24TP-PWR-SI	V100R005C01 and later versions
	S5700-48TP-PWR-SI	V100R005C01 and later versions
	S5700-28C-PWR-SI	V200R001C00 and later versions
	S5700-52C-PWR-SI	V200R001C00 and later versions
	S5700-26X-SI-12S-AC	V200R002C00 and later versions

2.5.2 Appearance and Structure

Front View

Table 2-30 shows the front view of the S5700-SI chassis.

Table 2-30 Front view of the S5700-SI chassis

Model	Image
S5700-28C-SI	
S5700-28C-PWR-SI	

Model	Image
S5700-52C-SI	<p>Diagram showing the front panel of the S5700-52C-SI switch. It features 52 RJ45 ports arranged in four groups of 13. Labels 3, 4, 5, 6, and 7 point to the top edge, the first four ports of the first group, and the management ports, respectively.</p>
S5700-52C-PWR-SI	<p>Diagram showing the front panel of the S5700-52C-PWR-SI switch. It features 52 RJ45 ports arranged in four groups of 13. Labels 3, 4, 5, 6, and 7 point to the top edge, the first four ports of the first group, and the management ports, respectively.</p>
S5700-24TP-SI-AC	<p>Diagram showing the front panel of the S5700-24TP-SI-AC switch. It features 24 RJ45 ports in two groups of 12, a power jack, and management ports. Labels 8, 9, 10, 1, 2, 4, 5, and 6 point to the power jack, the two groups of ports, and the management ports.</p>
S5700-24TP-SI-DC	<p>Diagram showing the front panel of the S5700-24TP-SI-DC switch. It features 24 RJ45 ports in two groups of 12, a power jack, and management ports. Labels 11, 9, 10, 1, 2, 4, 5, and 6 point to the power jack, the two groups of ports, and the management ports.</p>
S5700-48TP-SI-AC S5700-48TP-SI-DC	<p>Diagram showing the front panel of the S5700-48TP-SI-AC and S5700-48TP-SI-DC switches. They feature 48 RJ45 ports in four groups of 12, a power jack, and management ports. Labels 12, 4, 5, 6, and 2 point to the top edge, the four groups of ports, and the management ports.</p>
S5700-24TP-PWR-SI	<p>Diagram showing the front panel of the S5700-24TP-PWR-SI switch. It features 24 RJ45 ports in two groups of 12, a power jack, and management ports. Labels 1, 2, 4, 5, and 6 point to the two groups of ports and the management ports.</p>
S5700-48TP-PWR-SI	<p>Diagram showing the front panel of the S5700-48TP-PWR-SI switch. It features 48 RJ45 ports in four groups of 12, a power jack, and management ports. Labels 12, 4, 5, 6, and 2 point to the top edge, the four groups of ports, and the management ports.</p>
S5700-26X-SI-12S-AC	<p>Diagram showing the front panel of the S5700-26X-SI-12S-AC switch. It features 26 ports: 24 RJ45 ports in two groups of 12, two SFP ports, and two management ports. Labels 13, 14, 15, 5, 4, and 6 point to the two groups of ports, the two SFP ports, and the two management ports.</p>





1. Twenty 10/100/1000BASE-T Ethernet electrical ports	2. Four combo ports	3. Forty-eight 10/100/1000BASE-T Ethernet electrical ports	4. One console port
5. One ETH management port	6. One USB port NOTE The USB port is used to connect USB disks for deployment, configuration file transfer, and file upgrade.	7. Front card slot NOTE For details about the mapping between cards and the switch, see Cards .	8. AC socket NOTE It is used with an AC power cable .
9. Power switch	10. Backup power socket NOTE This socket can be connected to a backup power supply unit. The backup power supply unit must provide 12 V DC output voltage (ranging from 11 V to 13 V) and a minimum power of 100 W.	11. DC power terminal NOTE It is used with a DC power cable .	12. Forty-four 10/100/1000BASE-T Ethernet electrical ports
13. Twelve 100/1000BASE-X Ethernet optical ports	14. Twelve 10/100/1000BASE-T Ethernet electrical ports	15. Two 10GE SFP+ Ethernet optical ports	-

Rear View

Table 2-31 shows the rear view of the S5700-SI chassis.

Table 2-31 Rear view of the S5700-SI chassis

Model	Image
S5700-28C-SI S5700-52C-SI	<p>The image shows the rear panel of the S5700-SI chassis. Callout 1 points to the power switch, callout 2 points to the backup power socket, callout 3 points to the DC power terminal, and callout 4 points to the AC power socket.</p>

Model	Image
S5700-28C-PWR-SI S5700-52C-PWR-SI S5700-24TP-PWR-SI S5700-48TP-PWR-SI	
S5700-24TP-SI-AC S5700-24TP-SI-DC	
S5700-48TP-SI-AC	
S5700-48TP-SI-DC	
S5700-26X-SI-12S-AC	

<p>1. ESD jack</p> <p>NOTE</p> <p>When you install or maintain an S5700-SI chassis, wear an ESD wrist strap and insert the other end of the ESD wrist strap into this ESD jack.</p>	<p>2. Rear card slot</p> <p>NOTE</p> <p>For details about the mapping between cards and the switch, see Cards.</p>	<p>3. Fan module slot</p> <p>NOTE</p> <p>Available fans: CX7E1FANA Fan Module</p>	<p>4. Power module slot</p> <p>NOTE</p> <p>Available power modules:</p> <ul style="list-style-type: none"> PoE switch: 250 W AC PoE Power Module; 500 W AC PoE Power Module Non-PoE switch: 150 W AC Power Module; 150 W DC Power Module
--	---	--	---

<p>5. Backup power socket</p> <p>NOTE This socket can be connected to a backup power supply unit. The backup power supply unit must provide 12 V DC output voltage (ranging from 11 V to 13 V) and a minimum power of 100 W.</p>	<p>6. Ground screw</p> <p>NOTE It is used with a ground cable.</p>	<p>7. Power switch</p>	<p>8. AC socket</p> <p>NOTE It is used with an AC power cable.</p>
<p>9. DC power terminal</p> <p>NOTE It is used with a DC power cable.</p>	<p>10. RPS socket</p> <p>NOTE It is used with an RPS cable which is not hot swappable.</p>	<p>11. Jack for AC terminal locking latch</p> <p>NOTE The AC terminal locking latch is not delivered with the device. Customers need to prepare the locking latch themselves if they need it.</p>	<p>-</p>

2.5.3 Indicator Description

S5700-24TP-SI-AC

 **NOTE**

Symbols and meanings of indicators on the S5700-24TP-SI-DC, the S5700-48TP-SI-AC, and the S5700-48TP-SI-DC are the same as those on the S5700-24TP-SI-AC.

Figure 2-13 Indicators on the S5700-24TP-SI-AC

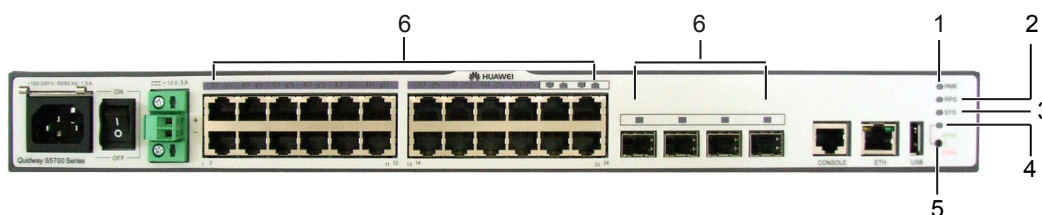

Table 2-32 Description of indicators on the S5700-24TP-SI-AC

Number	Indicator/ Button	Color	Description
1	PWR: power supply indicator	Off	The switch is powered off.

Number	Indicator/ Button	Color	Description
		Green	Steady on: The switch is powered on.
		Yellow	Steady on: The internal power module is faulty, and the switch is powered by the backup power.
2	RPS: backup power supply indicator	Off	No backup power is connected to the switch or the backup power is faulty.
		Green	Steady on: The backup power is connected to the switch.
3	SYS: system status indicator	Off	The system is not running.
		Green	<ul style="list-style-type: none"> ● Steady on: The system is not operating properly or is starting. ● Blinking once every 2s (0.5 Hz): The system is operating properly. ● Blinking once every 0.25s (4 Hz): The system is copying the system software and configuration file from a USB flash drive.
		Yellow	<ul style="list-style-type: none"> ● Steady on: The system is performing self-check during startup. ● Blinking once every 2s (0.5 Hz): The system has been successfully upgraded using a USB flash drive and the switch has restarted. You can remove the USB flash drive from the switch.
		Red	<ul style="list-style-type: none"> ● Steady on: After registering, the system does not operate properly, or a fan alarm, or temperature alarm is generated. ● Blinking once every 0.25s (4 Hz): An error occurred during USB-based upgrade and the system failed to be upgraded after a USB flash drive is inserted.
4	Mode indicator	Off	The service port indicators are in the default mode (STAT).
		Green	Steady on: The service port indicators indicate the port speed. After 45 seconds, the service port indicators automatically restore to STAT mode.

Number	Indicator/ Button	Color	Description
		Red	Steady on: The service port indicators indicate the stack ID of the switch. After 45 seconds, the service port indicators automatically restore to STAT mode.
5	Mode switch button	-	<ul style="list-style-type: none"> When you press the button once, the mode indicator turns green and the service port indicators show the speed of each port. When you press the button for a second time, the mode indicator turns red and the service port indicators show the stack status. When you press the button for a third time, the mode indicator turns off. If you do not press the button within 45 seconds, the mode indicator restores to STAT mode.
6	Service port indicator	The meaning of the service port indicator varies with the current mode. For details, see Table 2-35 .	

S5700-28C-SI

 **NOTE**

Symbols and meanings of indicators on the S5700-52C-SI are the same as those on the S5700-28C-SI.

Figure 2-14 Indicators on the S5700-28C-SI

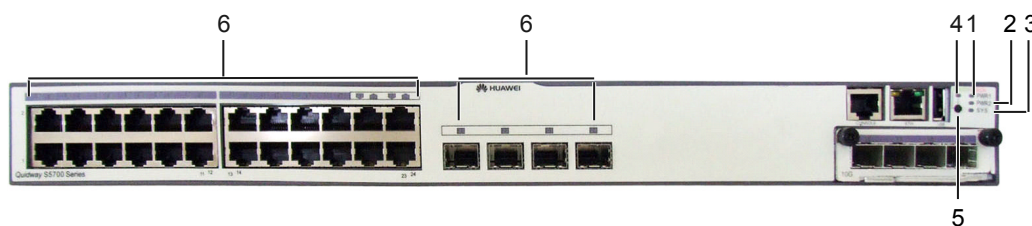

Table 2-33 Description of indicators on the S5700-28C-SI

Number	Indicator/ Button	Color	Description
1	PWR1: power supply indicator	Off	The PWR1 slot has no power module installed, or the power module is faulty when a single power module is used.

Number	Indicator/ Button	Color	Description
		Green	Steady on: The power module is working properly.
		Red	Steady on: Any of the following situations occur: <ul style="list-style-type: none"> ● Dual power modules are installed, but not switched on. ● Dual power modules are installed, but receive no input power. ● The power modules are faulty.
2	PWR2: power supply indicator	Off	The PWR2 slot has no power module installed, or the power module is faulty when a single power module is used.
		Green	Steady on: The power module is working properly.
		Red	Steady on: Any of the following situations occur: <ul style="list-style-type: none"> ● Dual power modules are installed, but not switched on. ● Dual power modules are installed, but receive no input power. ● The power modules are faulty.
3	SYS: system status indicator	Off	The system is not running.
		Green	<ul style="list-style-type: none"> ● Steady on: The system is not operating properly or is starting. ● Blinking once every 2s (0.5 Hz): The system is operating properly. ● Blinking once every 0.25s (4 Hz): The system is copying the system software and configuration file from a USB flash drive.
		Yellow	<ul style="list-style-type: none"> ● Steady on: The system is performing self-check during startup. ● Blinking once every 2s (0.5 Hz): The system has been successfully upgraded using a USB flash drive and the switch has restarted. You can remove the USB flash drive from the switch.

Number	Indicator/ Button	Color	Description
		Red	<ul style="list-style-type: none"> Steady on: After registering, the system does not operate properly, or a fan alarm, or temperature alarm is generated. Blinking once every 0.25s (4 Hz): An error occurred during USB-based upgrade and the system failed to be upgraded after a USB flash drive is inserted.
4	MODE: mode indicator	Off	The service port indicators are in the default mode (STAT).
		Green	Steady on: The service port indicators indicate the port speed. After 45 seconds, the service port indicators automatically restore to STAT mode.
		Red	Steady on: The service port indicators indicate the stack ID of the switch. After 45 seconds, the service port indicators automatically restore to STAT mode.
5	Mode switch button	-	<ul style="list-style-type: none"> When you press the button once, the mode indicator turns green and the service port indicators show the speed of each port. When you press the button for a second time, the mode indicator turns red and the service port indicators show the stack status. When you press the button for a third time, the mode indicator turns off. <p>If you do not press the button within 45 seconds, the mode indicator restores to STAT mode.</p>
6	Service port indicator	The meaning of the service port indicator varies with the current mode. For details, see Table 2-35 .	

S5700-28C-PWR-SI

 **NOTE**

Symbols and meanings of indicators on the S5700-52C-PWR-SI, the S5700-24TP-PWR-SI, and the S5700-48TP-PWR-SI are the same as those on the S5700-28C-PWR-SI.

Figure 2-15 Indicators on the S5700-28C-PWR-SI

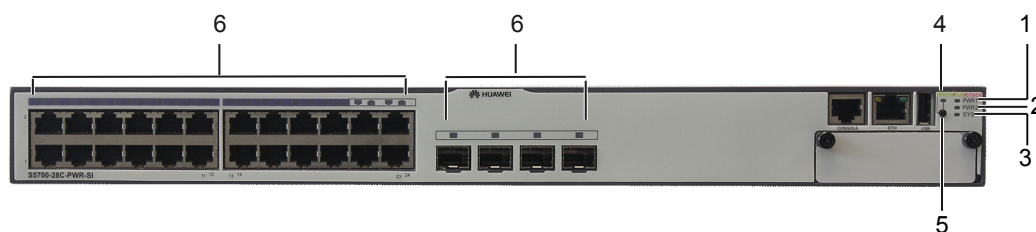

Table 2-34 Description of indicators on the S5700-28C-PWR-SI

Number	Indicator/ Button	Color	Description
1	PWR1: power supply indicator	Off	The PWR1 slot has no power module installed, or the power module is faulty when a single power module is used.
		Green	Steady on: The power module is working properly.
		Red	Steady on: Any of the following situations occur: <ul style="list-style-type: none"> ● Dual power modules are installed, but not switched on. ● Dual power modules are installed, but receive no input power. ● The system power and PoE power are faulty.
		Yellow	Steady on: If a single power module is installed, the PoE power is out of range. If dual power modules are installed, the system power or PoE power is out of range.
2	PWR2: power supply indicator	Off	The PWR2 slot has no power module installed, or the power module is faulty when a single power module is used.
		Green	Steady on: The power module is working properly.
		Red	Steady on: Any of the following situations occur: <ul style="list-style-type: none"> ● Dual power modules are installed, but not switched on. ● Dual power modules are installed, but receive no input power. ● The system power and PoE power are faulty.

Number	Indicator/ Button	Color	Description
		Yellow	Steady on: If a single power module is installed, the PoE power is out of range. If dual power modules are installed, the system power or PoE power is out of range.
3	SYS: system status indicator	Off	The system is not running.
		Green	<ul style="list-style-type: none"> ● Steady on: The system is not operating properly or is starting. ● Blinking once every 2s (0.5 Hz): The system is operating properly. ● Blinking once every 0.25s (4 Hz): The system is copying the system software and configuration file from a USB flash drive.
		Yellow	<ul style="list-style-type: none"> ● Steady on: The system is performing self-check during startup. ● Blinking once every 2s (0.5 Hz): The system has been successfully upgraded using a USB flash drive and the switch has restarted. You can remove the USB flash drive from the switch.
		Red	<ul style="list-style-type: none"> ● Steady on: After registering, the system does not operate properly, or a fan alarm, or temperature alarm is generated. ● Blinking once every 0.25s (4 Hz): An error occurred during USB-based upgrade and the system failed to be upgraded after a USB flash drive is inserted.
4	Mode indicator	Off	The service port indicators are in the default mode (STAT).
		Green	Steady on: The service port indicators indicate the port speed. After 45 seconds, the service port indicators automatically restore to STAT mode.
		Yellow	Steady on: The service port indicators indicate the PoE status. After 45 seconds, the service port indicators automatically restore to STAT mode.
		Red	Steady on: The service port indicators indicate the stack ID of the switch. After 45 seconds, the service port indicators automatically restore to STAT mode.

Number	Indicator/ Button	Color	Description
5	Mode switch button	-	<ul style="list-style-type: none"> ● When you press the button once, the mode indicator turns green and the service port indicators show the speed of each port. ● When you press the button for a second time, the mode indicator turns yellow and the service port indicators show the PoE status. ● When you press the button for a third time, the mode indicator turns red and the service port indicators show the stack status. ● When you press the button for a fourth time, the mode indicator turns off. <p>If you do not press the button within 45 seconds, the mode indicator restores to STAT mode.</p>
6	Service port indicator	The meaning of the service port indicator varies with the current mode. For details, see Table 2-35 .	

Table 2-35 Description of service port indicators in different modes

Display Mode	Color	Meaning
STAT mode	Off	The port is not connected or has been shut down.
	Green	<ul style="list-style-type: none"> ● Steady on: The port is connected. ● Blinking: The port is sending or receiving data.
SPED mode	Off	The port is not connected or has been shut down.
	Green	<ul style="list-style-type: none"> ● Steady on: <ul style="list-style-type: none"> 10M/100M/1000M port: The port is operating at a speed of 10/100 Mbit/s. 1000M/10GE port: The port is operating at a speed of 1000 Mbit/s. ● Blinking: <ul style="list-style-type: none"> 10M/100M/1000M port: The port is operating at a speed of 1000 Mbit/s. 1000M/10GE port: The port is operating at a speed of 10 Gbit/s.

Display Mode	Color	Meaning
PoE mode	Off	The port does not provide PoE power.
	Green	<ul style="list-style-type: none"> ● Steady on: The port is providing PoE power. ● Blinking: The power of a connected PD exceeds the port's power supply capability or upper power threshold.
STCK mode	Off	Port indicators do not show the stack ID of the switch.
	Green	<ul style="list-style-type: none"> ● Steady on: <ul style="list-style-type: none"> The switch is not a master switch: <ul style="list-style-type: none"> - If the indicator of a port is steady on, the number of this port is the stack ID of the switch. - If the first nine port indicators of the switch are steady on, the stack ID of the switch is 0. ● Blinking: <ul style="list-style-type: none"> The switch is a master switch: <ul style="list-style-type: none"> - If the indicator of a port is blinking, the number of this port is the stack ID of the switch. - If the first nine port indicators of the switch are blinking, the stack ID of the switch is 0.

S5700-26X-SI-12S-AC

Figure 2-16 Indicators on the S5700-26X-SI-12S-AC

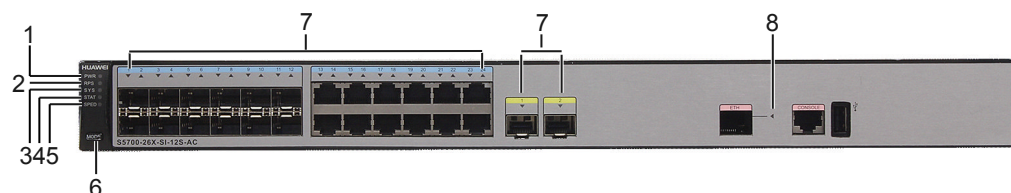

Table 2-36 Description of indicators on the S5700-26X-SI-12S-AC

Number	Indicator/ Button	Color	Description
1	PWR: power supply indicator	Off	The switch is powered off.
		Green	Steady on: The switch is powered on.
2	RPS: RPS power supply indicator	Off	No RPS is connected to the switch.
		Green	<ul style="list-style-type: none"> ● Steady on: The RPS is in cold backup state or forced power-on state. ● Blinking: The RPS is providing power for another device and cannot provide power for the current switch.
		Yellow	<ul style="list-style-type: none"> ● Steady on: The RPS is in alarm state. ● Blinking: The RPS is providing power for the switch and the built-in power module of the switch is faulty.
3	SYS: system status indicator	Off	The system is not running.
		Green	<ul style="list-style-type: none"> ● Blinking once every 0.25s (4 Hz): The system is starting or is copying the system software and configuration file from a USB flash drive. ● Blinking once every 2s (0.5 Hz): The system is operating properly.
		Yellow	Blinking once every 2s (0.5 Hz): The system has been successfully upgraded using a USB flash drive and the switch has restarted. You can remove the USB flash drive from the switch.
		Red	<ul style="list-style-type: none"> ● Steady on: The system cannot start normally, or a temperature alarm or fan alarm is generated. ● Blinking once every 0.25s (4 Hz): An error occurred during USB-based upgrade and the system failed to be upgraded after a USB flash drive is inserted.
4	STAT: status indicator in STAT mode	Off	The STAT mode is not selected.
		Green	Steady on: The service port indicators are in the default mode (STAT).
5	SPED: status indicator in speed mode	Off	The SPED mode is not selected.

Number	Indicator/ Button	Color	Description
		Green	Steady on: The service port indicators indicate the port speed. After 45 seconds, the service port indicators automatically restore to STAT mode.
6	MODE: mode switch button	-	<ul style="list-style-type: none"> When you press the button once, the SPED indicator turns green and the service port indicators show the speed of each port. When you press the button for a second time, the STAT indicator turns green. <p>If you do not press the button within 45 seconds, the indicators restore to the default status. That is, the STAT indicator turns green, and the SPED indicator is off.</p>
7	Service port indicator <ul style="list-style-type: none"> GE electrical/optical port: The first indicator shows the status of the bottom left port. The indicators correspond to the ports from bottom to top and from left to right. 10GE optical port: Each optical port has a corresponding indicator above it. 	The meaning of the service port indicator varies with the current mode. For details, see Table 2-35 .	
8	ETH indicator	Off	The port is not connected.
		Green	<ul style="list-style-type: none"> Steady on: The port is connected. Blinking: The port is sending or receiving data.

2.5.4 Port Description

10/100/1000BASE-T Ethernet Electrical Port

A 10/100/1000BASE-T Ethernet electrical port receives and sends services at a speed of 10/100/1000 Mbit/s. The ports must use **network cables**. [Table 2-37](#) describes the attributes of a 10/100/1000BASE-T Ethernet electrical port.

Table 2-37 Attributes of a 10/100/1000BASE-T Ethernet electrical port

Attribute	Description
Connector type	RJ45
Standards compliance	IEEE802.3, IEEE802.3u, IEEE802.3ab
Electrical port	MDI/MDIX NOTE <ul style="list-style-type: none">● A medium dependent interface (MDI) describes the interface (both physical and electrical) in a computer network from a physical layer implementation to the physical medium used to carry the transmission. The Ethernet ports of most NICs are MDIs.● An MDIX (for MDI crossover) is a version of MDI that enables connection between like devices. MDIX ports are usually used on hubs or LAN switches.
Frame format	Ethernet_II, Ethernet_SAP, Ethernet_SNAP
Network protocol	IP
Working mode	10/100/1000 Mbit/s auto-sensing Full duplex
Maximum transmission distance	100 m

100/1000BASE-X Ethernet Optical Port

A 100/1000BASE-X Ethernet optical port receives and sends services at a speed of 100/1000 Mbit/s. [Table 2-38](#) describes the attributes of a 100/1000BASE-X Ethernet optical port.

Table 2-38 Attributes of a 100/1000BASE-X Ethernet optical port

Attribute	Description
Connector type	LC/PC
Optical port attribute	Depending on the optical module used on the port (see SFP/eSFP Modules)

Attribute	Description
Standards compliance	IEEE802.3z
Frame format	Ethernet_II, Ethernet_SAP, Ethernet_SNAP
Network protocol	IP
Working mode	100/1000 Mbit/s auto-sensing Full duplex

10GE SFP+ Ethernet Optical Port

A 10GE SFP+ Ethernet optical port supports auto-sensing to 1000 Mbit/s. It receives and sends services at a speed of 1000 Mbit/s or 10 Gbit/s. [Table 2-39](#) describes the attributes of a 10GE SFP+ Ethernet optical port.

Table 2-39 Attributes of a 10GE SFP+ Ethernet optical port

Attribute	Description
Connector type	LC/PC
Optical port attribute	Depending on the optical module used on the port (see SFP+ Modules)
Standards compliance	IEEE802.3ae
Frame format	Ethernet_II, Ethernet_SAP, Ethernet_SNAP
Network protocol	IP
Working mode	GE/10GE auto-sensing Full duplex

Combo Port

A combo port consists of an optical Ethernet port and an electrical Ethernet port on the panel. Each combo port matches only one internal forwarding port. A combo port is a multiplexing port, and you can use either the optical port or electrical port at one time. When one of the Ethernet ports is used, the other port is disabled.

NOTE

By default, a combo port works in the auto mode. In the auto mode, if the electrical port is connected to a network cable first, the combo port works as an electrical port to transmit data; if the optical port is connected to a fiber first, the combo port works as an optical port to transmit data. When both optical port and electrical port are connected, the optical port takes the priority. You can run the **combo-port** command to set the working mode of the combo port.

Console Port

The console port is connected to a console for on-site configuration. The port must use a **console cable**. The console port is used when a switch is powered on for the first time. For details about the attributes of a console port, see **Table 2-40**.

Table 2-40 Attributes of a console port

Attribute	Description
Connector type	RJ45
Standards compliance	RS-232
Working mode	Duplex Universal Asynchronous Receiver/Transmitter (UART)
Baud rate	9600 bit/s to 115200 bit/s Default value: 9600 bit/s
Data equipment type	Data circuit-terminating equipment (DCE)

ETH Management Port

An ETH management port is connected to the network port of a configuration terminal or network management workstation to set up the on-site or remote configuration environment. The port must use a **network cable**. **Table 2-41** describes the attributes of an ETH management port.

Table 2-41 Attributes of an ETH management port

Attribute	Description
Connector type	RJ45
Standards compliance	IEEE802.3
Working mode	10/100 Mbit/s auto-sensing Full duplex
Maximum transmission distance	100 m

2.5.5 Power Supply

PoE Power Supply Configuration

The S5700-SI PoE switches include: S5700-48TP-PWR-SI, S5700-52C-PWR-SI, S5700-24TP-PWR-SI, and S5700-28C-PWR-SI.

The PoE switch provides two power module slots, each supporting a 500 W or 250 W power module. A single power module provides 369.6 W or 123.2 W PoE power for the PDs. The power supply configurations are shown in [Table 2-42](#).

Table 2-42 Power supply configurations

Power Module		PoE Power	Device	Maximum Number of Ports (Fully Loaded)
250 W	-	123.2 W	<ul style="list-style-type: none"> ● S5700-48TP-PWR-SI ● S5700-52C-PWR-SI ● S5700-24TP-PWR-SI ● S5700-28C-PWR-SI 	<ul style="list-style-type: none"> ● 802.3af (15.4 W per port): 8 ● 802.3at (30 W per port): 4
500 W	-	369.6 W	<ul style="list-style-type: none"> ● S5700-48TP-PWR-SI ● S5700-52C-PWR-SI ● S5700-24TP-PWR-SI ● S5700-28C-PWR-SI 	<ul style="list-style-type: none"> ● 802.3af (15.4 W per port): 24 ● 802.3at (30 W per port): 12
250 W	250 W	246.4 W	<ul style="list-style-type: none"> ● S5700-48TP-PWR-SI ● S5700-52C-PWR-SI ● S5700-24TP-PWR-SI ● S5700-28C-PWR-SI 	<ul style="list-style-type: none"> ● 802.3af (15.4 W per port): 16 ● 802.3at (30 W per port): 8
500 W	500 W	739.2 W	<ul style="list-style-type: none"> ● S5700-48TP-PWR-SI ● S5700-52C-PWR-SI 	<ul style="list-style-type: none"> ● 802.3af (15.4 W per port): 48 ● 802.3at (30 W per port): 24
			S5700-28C-PWR-SI	<ul style="list-style-type: none"> ● 802.3af (15.4 W per port): 24 ● 802.3at (30 W per port): 24

Power Module		PoE Power	Device	Maximum Number of Ports (Fully Loaded)
		369.6 W	S5700-24TP-PWR-SI	<ul style="list-style-type: none"> ● 802.3af (15.4 W per port): 24 ● 802.3at (30 W per port): 12



NOTE

When two power modules are used, they work in redundancy mode to provide power for the switch and in load balancing mode to provide power for the PDs.

Figure 2-17 shows the power supply mode of a PoE AC power module. After AC power is transmitted to the PWR module, the PWR module provides 12 V and -53 V output voltages, and the motherboard provides 12 V voltage for the entire device and -53 V voltage for the PDs.

Figure 2-17 Power supply mode of a PoE AC power module

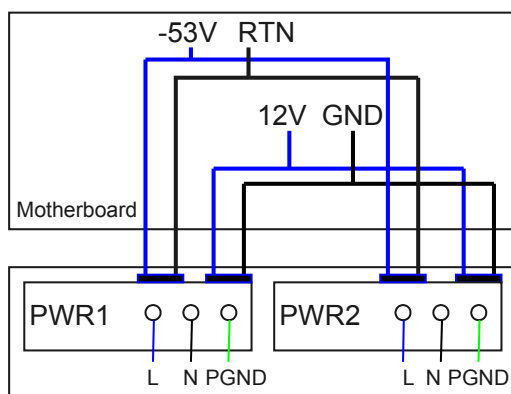

L: Live wire N: Neutral wire PGND: Protective ground wire GND: 12 V reference ground RTN: -53 V reference ground

Non-PoE Power Supply Configuration

On the S5700-SI non-PoE switch, one or two power modules can be configured.

When two power modules are used, they work in 1+1 backup mode to provide power for the device. An AC power module and a DC power module cannot be configured at the same time.

S5700-24TP-SI-AC, S5700-24TP-SI-DC, S5700-48TP-SI-AC, and S5700-48TP-SI-DC have a single built-in power module and can connect to the DC backup power.

The S5700-26X-SI-12S-AC has a single built-in power module and can connect to the RPS1800.

Figure 2-18 shows the power supply mode of dual DC power modules. After DC power is transmitted to the PWR module, the PWR module provides 12 V output voltage, and the motherboard provides power for the entire device.

Figure 2-18 Power supply mode of dual DC power modules

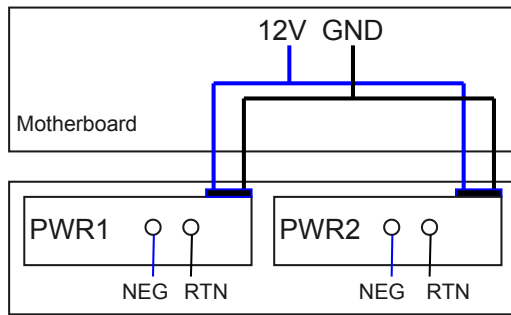

NEG: Power cable RTN: Power return cable GND: 12 V reference ground

Figure 2-19 shows the power supply mode of dual non-PoE AC power modules. After AC power is transmitted to the PWR module, the PWR module provides 12 V output voltage, and the motherboard provides power for the entire device.

Figure 2-19 Power supply mode of dual non-PoE AC power modules

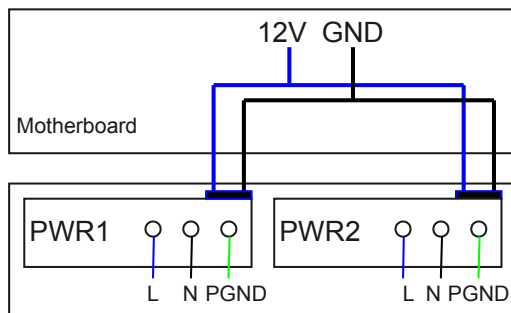

L: Live wire N: Neutral wire PGND: Protective ground wire GND: 12 V reference ground

Figure 2-20 shows the power supply mode of a single non-PoE AC power module. After AC power is transmitted to the PWR module on the switch, the PWR module provides 12 V output voltage for the entire device.

Figure 2-20 Power supply mode of a single non-PoE AC power module

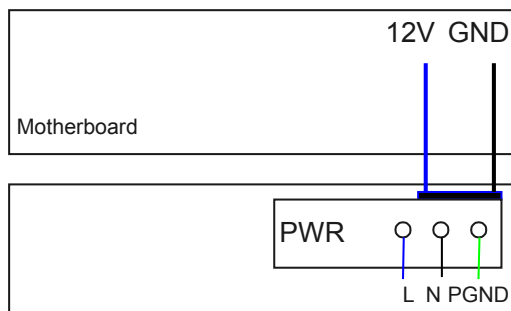



L: Live wire N: Neutral wire PGND: Protective ground wire GND: 12 V reference ground

2.5.6 Heat Dissipation

Table 2-43 shows the heat dissipation modes of the S5700-SI.

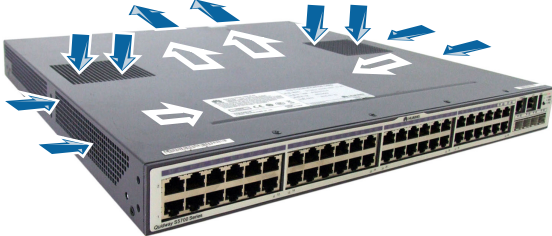
Table 2-43 S5700-SI heat dissipation modes

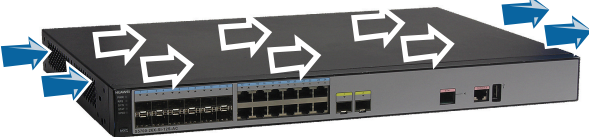
Heat Dissipation Mode	Model	Air Flow in the Chassis
Intelligent heat dissipation	<ul style="list-style-type: none"> ● S5700-48TP-SI-AC ● S5700-48TP-SI-DC ● S5700-24TP-SI-AC ● S5700-24TP-SI-DC 	<p>The air flows in from the left, right, or top and flows out from the rear.</p> 
Forcible heat dissipation	<ul style="list-style-type: none"> ● S5700-48TP-PWR-SI ● S5700-52C-PWR-SI ● S5700-24TP-PWR-SI ● S5700-28C-PWR-SI ● S5700-28C-SI ● S5700-52C-SI 	<p>The air flows in from the left or right and flows out from the rear.</p> 
	S5700-26X-SI-12S-AC	<p>The air flows in from the left and flows out from the right.</p> 

2.5.7 Specifications

Table 2-44 lists specifications of the S5700-SI.

Table 2-44 Specifications of the S5700-SI

Item	Description
CPU	800 MHz dominant frequency
Packet forwarding capacity Switching capacity	<ul style="list-style-type: none"> ● S5700-48TP-SI-AC: 72 Mpps, 288 Gbit/s ● S5700-48TP-SI-DC: 72 Mpps, 288 Gbit/s ● S5700-24TP-SI-AC: 36 Mpps, 144 Gbit/s ● S5700-24TP-SI-DC: 36 Mpps, 144 Gbit/s ● S5700-48TP-PWR-SI: 72 Mpps, 288 Gbit/s ● S5700-52C-PWR-SI: 132 Mpps, 288 Gbit/s ● S5700-24TP-PWR-SI: 36 Mpps, 144 Gbit/s ● S5700-28C-PWR-SI: 96 Mpps, 144 Gbit/s ● S5700-28C-SI: 96 Mpps, 144 Gbit/s ● S5700-52C-SI: 132 Mpps, 288 Gbit/s ● S5700-26X-SI-12S-AC: 66 Mpps, 144 Gbit/s
DDR memory	256 MB
Flash memory	S5700-26X-SI-12S-AC: 200 MB, others: 32 MB
Mean time between failures (MTBF)	<ul style="list-style-type: none"> ● S5700-48TP-SI-AC: 34 years ● S5700-48TP-SI-DC: 34 years ● S5700-24TP-SI-AC: 37 years ● S5700-24TP-SI-DC: 37 years ● S5700-48TP-PWR-SI: 71.7 years ● S5700-24TP-PWR-SI: 84.3 years ● S5700-28C-PWR-SI: 53.6 years when a 2x10GE card is configured; 74.6 years when a 4xGE front card is configured; 25.68 years when a 4x10GE front subcard is configured ● S5700-52C-PWR-SI: 50.4 years when a 2x10GE card is configured; 68.6 years when a 4xGE front card is configured; 35.58 years when a 4x10GE front subcard is configured ● S5700-28C-SI: 53.7 years when a 2x10GE card is configured; 74.9 years when a 4xGE front card is configured; 29.58 years when a 4x10GE front subcard is configured ● S5700-52C-SI: 51.3 years when a 2x10GE card is configured; 70.3 years when a 4xGE front card is configured; 28.58 years when a 4x10GE front subcard is configured ● S5700-26X-SI-12S-AC: 91.74 years
Mean time to repair (MTTR)	2 hours
Availability	> 0.99999

Item		Description
Surge protection	Service port protection	<ul style="list-style-type: none"> ● Non-PoE switch: S5700-26X-SI-12S-AC: ± 6 kV in common mode; others: ± 2 kV in common mode ● PoE switch: ± 1 kV in common mode
	Power supply protection	<ul style="list-style-type: none"> ● AC: S5700-26X-SI-12S-AC: ± 6 kV in differential mode; ± 6 kV in common mode; others: ± 2 kV in differential mode; ± 4 kV in common mode ● DC: ± 1 kV in differential mode; ± 2 kV in common mode
Dimensions (W x D x H)		<ul style="list-style-type: none"> ● S5700-48TP-SI-AC: 442.0 mm x 420.0 mm x 43.6 mm ● S5700-48TP-SI-DC: 442.0 mm x 420.0 mm x 43.6 mm ● S5700-24TP-SI-AC: 442.0 mm x 220.0 mm x 43.6 mm ● S5700-24TP-SI-DC: 442.0 mm x 220.0 mm x 43.6 mm ● S5700-48TP-PWR-SI: 442.0 mm x 420.0 mm x 43.6 mm ● S5700-52C-PWR-SI: 442.0 mm x 420.0 mm x 43.6 mm ● S5700-24TP-PWR-SI: 442.0 mm x 420.0 mm x 43.6 mm ● S5700-28C-PWR-SI: 442.0 mm x 420.0 mm x 43.6 mm ● S5700-28C-SI: 442.0 mm x 420.0 mm x 43.6 mm ● S5700-52C-SI: 442.0 mm x 420.0 mm x 43.6 mm ● S5700-26X-SI-12S-AC: 442.0 mm x 310.0 mm x 43.6 mm
Weight	Fully loaded	≤ 8.5 kg
	Empty loaded	≤ 5 kg
Stack port		Two stack ports of the stack card NOTE The S5700-26X-SI-12S-AC does not support stacking.
RPS		Only the S5700-26X-SI-12S-AC supports the RPS.
PoE		The PWR series support PoE.
Input DC voltage	Rated input voltage range	-48 V DC to -60 V DC
	Maximum voltage range	-36 V DC to -72 V DC
Input AC voltage	Rated input voltage range	100 V AC to 240 V AC; 50/60 Hz

Item		Description
	Maximum voltage range	90 V AC to 264 V AC; 47 Hz to 63 Hz
	Maximum power consumption (100% throughput, 100% PoE loads, full speed of fans)	<ul style="list-style-type: none"> ● S5700-48TP-SI-AC: 64 W ● S5700-48TP-SI-DC: 64 W ● S5700-24TP-SI-AC: 40 W ● S5700-24TP-SI-DC: 40 W ● S5700-48TP-PWR-SI: 907 W (power consumption: 167 W; PoE: 740 W) ● S5700-52C-PWR-SI: 917 W (power consumption: 177 W; PoE: 740 W) ● S5700-24TP-PWR-SI: 455 W (power consumption: 85 W; PoE: 370 W) ● S5700-28C-PWR-SI: 836 W (power consumption: 96 W; PoE: 740 W) ● S5700-28C-SI: 56 W ● S5700-52C-SI: 78 W ● S5700-26X-SI-12S-AC: 42.3 W
Temperature	Operating temperature	S5700-26X-SI-12S-AC: 0°C to +50°C (at 0 m to 1800 m altitude); others: 0°C to +50°C NOTE When the altitude is between 1800 m and 4000 m, the operating temperature reduces 1°C every time the altitude increases 220 m.
	Storage temperature	-40°C to +70°C
	Noise under normal temperature (23°C, Sound Power)	<ul style="list-style-type: none"> ● S5700-48TP-SI-AC: 0 ● S5700-48TP-SI-DC: 0 ● S5700-24TP-SI-AC: 0 ● S5700-24TP-SI-DC: 0 ● S5700-48TP-PWR-SI: less than 51 dBA ● S5700-52C-PWR-SI: less than 45 dBA ● S5700-24TP-PWR-SI: less than 51 dBA ● S5700-28C-PWR-SI: less than 45 dBA ● S5700-28C-SI: less than 41 dBA ● S5700-52C-SI: less than 41 dBA ● S5700-26X-SI-12S-AC: less than 56.3 dBA
	Relative humidity	S5700-26X-SI-12S-AC: 5% RH to 95% RH; others: 10% RH to 90% RH, non-condensing

Item	Description
Operating altitude	S5700-26X-SI-12S-AC: 0 m to 4000 m; others: 0 m to 2000 m
EMC	<ul style="list-style-type: none"> ● CISPR22 Class A ● CISPR24 ● EN55022 Class A ● EN50024 ● ETSI EN 300 386 Class A ● CFR 47 FCC Part 15 Class A ● ICES 003 Class A ● AS/NZS CISPR22 Class A ● IEC61000-4-2 ● ITU-T K 20 ● ITU-T K 44
Environmental standard	<ul style="list-style-type: none"> ● RoHS ● REACH
Security	<ul style="list-style-type: none"> ● IEC 60950-1 ● EN 60950-1/A11/A12 ● UL 60950-1 ● CSA C22.2 No 60950-1 ● AS/NZS 60950.1
Laser safety	<ul style="list-style-type: none"> ● IEC60825-1 ● IEC60825-2 ● EN60825-1 ● EN60825-2

2.6 S5700-EI

2.6.1 Version Mapping

Table 2-45 lists the mapping between the S5700-EI chassis and software versions.

Table 2-45 Mapping between the S5700-EI chassis and software versions

Series	Model	Available Version
S5700-EI	S5700-28C-EI	V100R005C01 and later versions



Series	Model	Available Version
	S5700-28C-EI-24S	V100R005C01 and later versions
	S5700-52C-EI	V100R005C01 and later versions
	S5700-28C-PWR-EI	V100R005C01 and later versions
	S5700-52C-PWR-EI	V100R005C01 and later versions

2.6.2 Appearance and Structure

Front View

Table 2-46 shows the front view of the S5700-EI chassis.

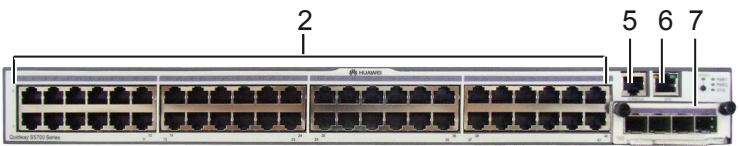
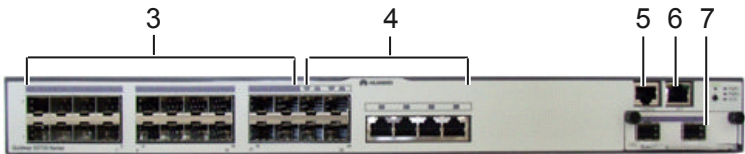
Table 2-46 Front view of the S5700-EI chassis

Model	Image
S5700-28C-EI	
S5700-52C-EI	
S5700-28C-EI-24S	
S5700-28C-PWR-EI	

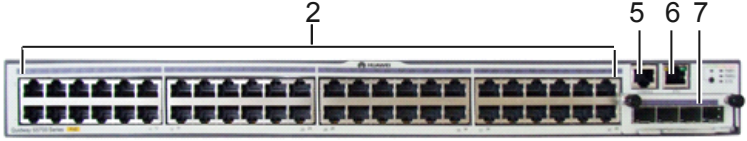

Model	Image
S5700-52C-PWR-EI	

1. Twenty-four 10/100/1000BASE-T Ethernet electrical ports	2. Forty-eight 10/100/1000BASE-T Ethernet electrical ports	3. Twenty 100/1000BASE-X Ethernet optical ports NOTE The ports support the 1000BASE-T SFP copper module.	4. Four combo ports
5. One console port	6. One ETH management port	7. Front card slot NOTE For details about the mapping between cards and the switch, see Cards .	-

Rear View

Table 2-47 shows the rear view of the S5700-EI chassis.

Table 2-47 Rear view of the S5700-EI chassis

Model	Image
S5700-28C-EI S5700-52C-EI S5700-28C-EI-24S	
S5700-28C-PWR-EI S5700-52C-PWR-EI	

<p>1. ESD jack</p> <p>NOTE</p> <p>When you install or maintain an S5700-EI chassis, wear an ESD wrist strap and insert the other end of the ESD wrist strap into this ESD jack.</p>	<p>2. Rear card slot</p> <p>NOTE</p> <p>For details about the mapping between cards and the switch, see Cards.</p>	<p>3. Fan module slot</p> <p>NOTE</p> <p>Available fans: CX7E1FANA Fan Module</p>	<p>4. Power module slot</p> <p>NOTE</p> <p>Available power modules:</p> <ul style="list-style-type: none"> ● PoE switch: 250 W AC PoE Power Module, 500 W AC PoE Power Module ● Non-PoE switch: 150 W AC Power Module, 150 W DC Power Module
--	---	--	---

2.6.3 Indicator Description

S5700-28C-EI



NOTE

Symbols and meanings of indicators on the S5700-52C-EI and S5700-28C-EI-24S are the same as those on the S5700-28C-EI.

Figure 2-21 Indicators on the S5700-28C-EI

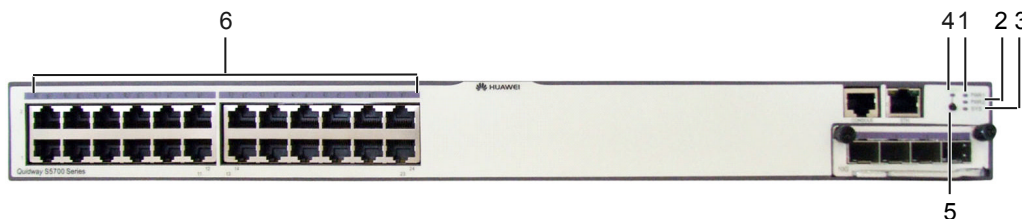

Table 2-48 Description of indicators on the S5700-28C-EI

Number	Indicator/ Button	Color	Description
1	PWR1: power supply indicator	Off	The PWR1 slot has no power module installed, or the power module is faulty when a single power module is used.
		Green	Steady on: The power module is working properly.

Number	Indicator/ Button	Color	Description
		Red	Steady on: Any of the following situations occur: <ul style="list-style-type: none"> ● Dual power modules are installed, but not switched on. ● Dual power modules are installed, but receive no input power. ● The power modules are faulty.
2	PWR2: power supply indicator	Off	The PWR2 slot has no power module installed, or the power module is faulty when a single power module is used.
		Green	Steady on: The power module is working properly.
		Red	Steady on: Any of the following situations occur: <ul style="list-style-type: none"> ● Dual power modules are installed, but not switched on. ● Dual power modules are installed, but receive no input power. ● The power modules are faulty.
3	SYS: system status indicator	Off	The system is not running.
		Green	<ul style="list-style-type: none"> ● Steady on: The system is not operating properly or is starting. ● Blinking: The system is operating properly.
		Yellow	Steady on: The system is performing self-check during startup.
		Red	Steady on: After registering, the system does not operate properly, or a fan alarm, or temperature alarm is generated.
4	MODE: mode indicator	Off	The service port indicators are in the default mode (STAT).
		Green	Steady on: The service port indicators indicate the port speed. After 45 seconds, the service port indicators automatically restore to STAT mode (the mode indicator turns off).
		Red	Steady on: The service port indicators indicate the stack ID of the switch. After 45 seconds, the service port indicators automatically restore to STAT mode.

Number	Indicator/Button	Color	Description
5	Mode switch button	-	<ul style="list-style-type: none"> When you press the button once, the mode indicator turns green and the service port indicators show the speed of each port. When you press the button for a second time, the mode indicator turns red and the service port indicators show the stack status. When you press the button for a third time, restores to STAT mode. <p>If you do not press the button within 45 seconds, the mode indicator restores to STAT mode.</p>
6	Service port indicator	The meaning of the service port indicator varies with the current mode. For details, see Table 2-50 .	

S5700-28C-PWR-EI

 **NOTE**

Symbols and meanings of indicators on the S5700-52C-PWR-EI are the same as those on the S5700-28C-PWR-EI.

Figure 2-22 Indicators on the S5700-28C-PWR-EI

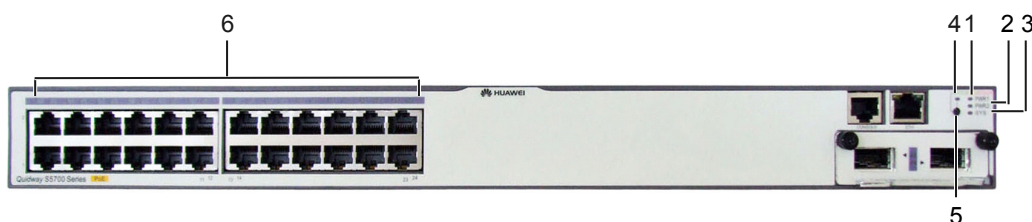

Table 2-49 Description of indicators on the S5700-28C-PWR-EI

Number	Indicator/Button	Color	Description
1	PWR1: power supply indicator	Off	The PWR1 slot has no power module installed, or the power module is faulty when a single power module is used.
		Green	Steady on: The power module is working properly.

Number	Indicator/ Button	Color	Description
		Red	Steady on: Any of the following situations occur: <ul style="list-style-type: none"> ● Dual power modules are installed, but not switched on. ● Dual power modules are installed, but receive no input power. ● The system power and PoE power are faulty.
		Yellow	Steady on: If a single power module is installed, the PoE power is out of range. If dual power modules are installed, the system power or PoE power is out of range.
2	PWR2: power supply indicator	Off	The PWR2 slot has no power module installed, or the power module is faulty when a single power module is used.
		Green	Steady on: The power module is working properly.
		Red	Steady on: Any of the following situations occur: <ul style="list-style-type: none"> ● Dual power modules are installed, but not switched on. ● Dual power modules are installed, but receive no input power. ● The system power and PoE power are faulty.
		Yellow	Steady on: If a single power module is installed, the PoE power is out of range. If dual power modules are installed, the system power or PoE power is out of range.
3	SYS: system status indicator	Off	The system is not running.
		Green	<ul style="list-style-type: none"> ● Steady on: The system is not operating properly or is starting. ● Blinking: The system is operating properly.
		Yellow	Steady on: The system is performing self-check during startup.
		Red	Steady on: After registering, the system does not operate properly, or a fan alarm, or temperature alarm is generated.

Number	Indicator/ Button	Color	Description
4	Mode indicator	Off	The service port indicators are in the default mode (STAT).
		Green	Steady on: The service port indicators indicate the port speed. After 45 seconds, the service port indicators automatically restore to STAT mode (the mode indicator turns off).
		Yellow	Steady on: The service port indicators indicate the PoE status. After 45 seconds, the service port indicators automatically restore to STAT mode.
		Red	Steady on: The service port indicators indicate the stack ID of the switch. After 45 seconds, the service port indicators automatically restore to STAT mode.
5	Mode switch button	-	<ul style="list-style-type: none"> ● When you press the button once, the mode indicator turns green and the service port indicators show the speed of each port. ● When you press the button for a second time, the mode indicator turns yellow and the service port indicators show the PoE status. ● When you press the button for a third time, the mode indicator turns red and the service port indicators show the stack status. ● When you press the button for a fourth time, the mode indicator restores to STAT mode. <p>If you do not press the button within 45 seconds, the mode indicator restores to STAT mode.</p>
6	Service port indicator	The meaning of the service port indicator varies with the current mode. For details, see Table 2-50 .	

Table 2-50 Description of service port indicators in different modes

Display Mode	Color	Meaning
STAT mode	Off	The port is not connected or has been shut down.

Display Mode	Color	Meaning
	Green	<ul style="list-style-type: none"> ● Steady on: The port is connected. ● Blinking: The port is sending or receiving data.
SPED mode	Off	The port is not connected or has been shut down.
	Green	<ul style="list-style-type: none"> ● Steady on: <ul style="list-style-type: none"> 10M/100M/1000M port: The port is operating at a speed of 10/100 Mbit/s. 1000M/10GE port: The port is operating at a speed of 1000 Mbit/s. ● Blinking: <ul style="list-style-type: none"> 10M/100M/1000M port: The port is operating at a speed of 1000 Mbit/s. 1000M/10GE port: The port is operating at a speed of 10 Gbit/s.
PoE mode	Off	The port does not provide PoE power.
	Green	<ul style="list-style-type: none"> ● Steady on: The port is providing PoE power. ● Blinking: The power of a connected PD exceeds the port's power supply capability or upper power threshold.
STCK mode	Off	Port indicators do not show the stack ID of the switch.
	Green	<ul style="list-style-type: none"> ● Steady on: <ul style="list-style-type: none"> The switch is not a master switch: <ul style="list-style-type: none"> - If the indicator of a port is steady on, the number of this port is the stack ID of the switch. - If the first nine port indicators of the switch are steady on, the stack ID of the switch is 0. ● Blinking: <ul style="list-style-type: none"> The switch is a master switch: <ul style="list-style-type: none"> - If the indicator of a port is blinking, the number of this port is the stack ID of the switch. - If the first nine port indicators of the switch are blinking, the stack ID of the switch is 0.

2.6.4 Port Description

10/100/1000BASE-T Ethernet Electrical Port

A 10/100/1000BASE-T Ethernet electrical port receives and sends services at a speed of 10/100/1000 Mbit/s. The ports must use **network cables**. [Table 2-51](#) describes the attributes of a 10/100/1000BASE-T Ethernet electrical port.

Table 2-51 Attributes of a 10/100/1000BASE-T Ethernet electrical port

Attribute	Description
Connector type	RJ45
Standards compliance	IEEE802.3, IEEE802.3u, IEEE802.3ab
Electrical port	MDI/MDIX NOTE <ul style="list-style-type: none">● A medium dependent interface (MDI) describes the interface (both physical and electrical) in a computer network from a physical layer implementation to the physical medium used to carry the transmission. The Ethernet ports of most NICs are MDIs.● An MDIX (for MDI crossover) is a version of MDI that enables connection between like devices. MDIX ports are usually used on hubs or LAN switches.
Frame format	Ethernet_II, Ethernet_SAP, Ethernet_SNAP
Network protocol	IP
Working mode	10/100/1000 Mbit/s auto-sensing Full duplex
Maximum transmission distance	100 m

100/1000BASE-X Ethernet Optical Port

A 100/1000BASE-X Ethernet optical port receives and sends services at a speed of 100/1000 Mbit/s. [Table 2-52](#) describes the attributes of a 100/1000BASE-X Ethernet optical port.

Table 2-52 Attributes of a 100/1000BASE-X Ethernet optical port

Attribute	Description
Connector type	LC/PC
Optical port attribute	Depending on the optical module used on the port (see SFP/eSFP Modules)

Attribute	Description
Standards compliance	IEEE802.3z
Frame format	Ethernet_II, Ethernet_SAP, Ethernet_SNAP
Network protocol	IP
Working mode	100/1000 Mbit/s auto-sensing Full duplex

Combo Port

A combo port consists of an optical Ethernet port and an electrical Ethernet port on the panel. Each combo port matches only one internal forwarding port. A combo port is a multiplexing port, and you can use either the optical port or electrical port at one time. When one of the Ethernet ports is used, the other port is disabled.

NOTE

By default, a combo port works in the auto mode. In the auto mode, if the electrical port is connected to a network cable first, the combo port works as an electrical port to transmit data; if the optical port is connected to a fiber first, the combo port works as an optical port to transmit data. When both optical port and electrical port are connected, the optical port takes the priority. You can run the **combo-port** command to set the working mode of the combo port.

Console Port

The console port is connected to a console for on-site configuration. The port must use a **console cable**. The console port is used when a switch is powered on for the first time. For details about the attributes of a console port, see [Table 2-53](#).

Table 2-53 Attributes of a console port

Attribute	Description
Connector type	RJ45
Standards compliance	RS-232
Working mode	Duplex Universal Asynchronous Receiver/Transmitter (UART)
Baud rate	9600 bit/s to 115200 bit/s Default value: 9600 bit/s
Data equipment type	Data circuit-terminating equipment (DCE)

ETH Management Port

An ETH management port is connected to the network port of a configuration terminal or network management workstation to set up the on-site or remote configuration environment.

The port must use a **network cable**. [Table 2-54](#) describes the attributes of an ETH management port.

Table 2-54 Attributes of an ETH management port

Attribute	Description
Connector type	RJ45
Standards compliance	IEEE802.3
Working mode	10/100 Mbit/s auto-sensing Full duplex
Maximum transmission distance	100 m

2.6.5 Power Supply

PoE Power Supply Configuration

The S5700-EI PoE switches include: S5700-28C-PWR-EI and S5700-52C-PWR-EI.

The PoE switch provides two power module slots, each supporting a 500 W or 250 W power module. A single power module provides 369.6 W or 123.2 W PoE power for the PDs. The power supply configurations are shown in [Table 2-55](#).

Table 2-55 Power supply configurations

Power Module		PoE Power	Device	Maximum Number of Ports (Fully Loaded)
250 W	-	123.2 W	<ul style="list-style-type: none"> ● S5700-52C-PWR-EI ● S5700-28C-PWR-EI 	<ul style="list-style-type: none"> ● 802.3af (15.4 W per port): 8 ● 802.3at (30 W per port): 4
500 W	-	369.6 W	<ul style="list-style-type: none"> ● S5700-52C-PWR-EI ● S5700-28C-PWR-EI 	<ul style="list-style-type: none"> ● 802.3af (15.4 W per port): 24 ● 802.3at (30 W per port): 12
250 W	250 W	246.4 W	<ul style="list-style-type: none"> ● S5700-52C-PWR-EI ● S5700-28C-PWR-EI 	<ul style="list-style-type: none"> ● 802.3af (15.4 W per port): 16 ● 802.3at (30 W per port): 8

Power Module		PoE Power	Device	Maximum Number of Ports (Fully Loaded)
500 W	500 W	739.2 W	S5700-52C-PWR-EI	<ul style="list-style-type: none"> ● 802.3af (15.4 W per port): 48 ● 802.3at (30 W per port): 24
		739.2 W	S5700-28C-PWR-EI	<ul style="list-style-type: none"> ● 802.3af (15.4 W per port): 24 ● 802.3at (30 W per port): 24



NOTE

When two power modules are used, they work in redundancy mode to provide power for the switch and in load balancing mode to provide power for the PDs.

Figure 2-23 shows the power supply mode of a PoE AC power module. After AC power is transmitted to the PWR module, the PWR module provides 12 V and -53 V output voltages, and the motherboard provides 12 V voltage for the entire device and -53 V voltage for the PDs.

Figure 2-23 Power supply mode of a PoE AC power module

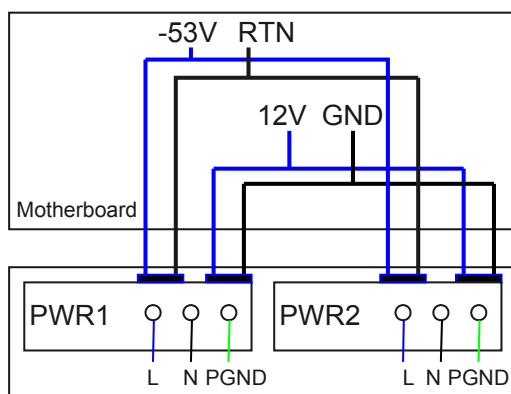

L: Live wire N: Neutral wire PGND: Protective ground wire GND: 12 V reference ground RTN: -53 V reference ground

Non-PoE Power Supply Configuration

On the S5700-EI non-PoE switch, one or two power modules can be configured.

When two power modules are used, they work in 1+1 backup mode to provide power for the device. An AC power module and a DC power module cannot be configured at the same time.

Figure 2-24 shows the power supply mode of dual DC power modules. After DC power is transmitted to the PWR module, the PWR module provides 12 V output voltage, and the motherboard provides power for the entire device.

Figure 2-24 Power supply mode of dual DC power modules

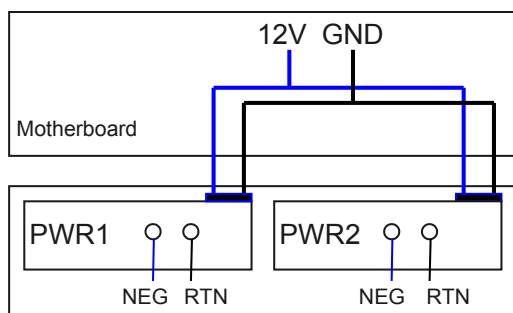

NEG: Power cable

RTN: Power return cable

GND: 12 V reference ground

Figure 2-25 shows the power supply mode of dual non-PoE AC power modules. After AC power is transmitted to the PWR module, the PWR module provides 12 V output voltage, and the motherboard provides power for the entire device.

Figure 2-25 Power supply mode of dual non-PoE AC power modules

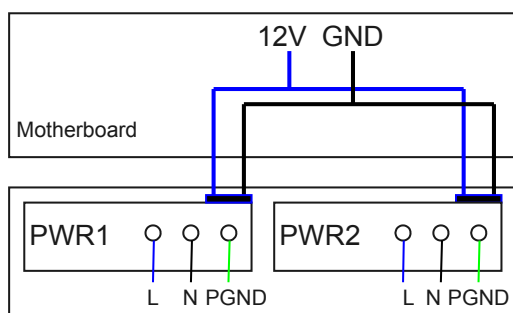

L: Live wire

N: Neutral wire

PGND: Protective ground wire

GND: 12 V reference ground

2.6.6 Heat Dissipation

Table 2-56 describes the heat dissipation modes of the S5700-EI.

Table 2-56 S5700-EI heat dissipation mode

Heat Dissipation Mode	Model	Air Flow in the Chassis
Forcible heat dissipation	<ul style="list-style-type: none"> ● S5700-28C-PWR-EI ● S5700-52C-PWR-EI ● S5700-52C-EI ● S5700-28C-EI ● S5700-28C-EI-24S 	<p>The air flows in from the left or right and flows out from the rear.</p> 

2.6.7 Specifications

[Table 2-57](#) lists specifications of the S5700-EI.

Table 2-57 Specifications of the S5700-EI

Item	Description
CPU	533 MHz dominant frequency
Packet forwarding capacity Switching capacity	<ul style="list-style-type: none"> ● S5700-28C-EI: 96 Mpps, 144 Gbit/s ● S5700-52C-EI: 132 Mpps, 288 Gbit/s ● S5700-28C-EI-24S: 96 Mpps, 144 Gbit/s ● S5700-28C-PWR-EI: 96 Mpps, 144 Gbit/s ● S5700-52C-PWR-EI: 132 Mpps, 288 Gbit/s
DDR memory	256 MB
Flash memory	32 MB

Item		Description
Mean time between failures (MTBF)		<ul style="list-style-type: none"> ● S5700-28C-EI: 53.11 years when a 2x10GE card is configured; 68.33 years when a 4xGE front card is configured; 25.52 years when a 4x10GE front card is configured ● S5700-52C-EI: 46.05 years when a 2x10GE card is configured; 57.08 years when a 4xGE front card is configured; 25.58 years when a 4x10GE front card is configured ● S5700-28C-EI-24S: 52.80 years when no card is configured; 41.33 years when a 2x10GE card is configured; 50.00 years when a 4xGE front card is configured; 26.52 years when a 4x10GE front card is configured ● S5700-28C-PWR-EI: 52 years when a 2x10GE card is configured; 55.4 years when a 4xGE front card is configured; 32.92 years when a 4x10GE front card is configured ● S5700-52C-PWR-EI: 44.8 years when a 2x10GE card is configured; 66.8 years when a 4xGE front card is configured; 29.89 years when a 4x10GE front card is configured
Mean time to repair (MTTR)		2 hours
Availability		> 0.99999
Surge protection	Service port protection	<ul style="list-style-type: none"> ● Non-PoE switch: ± 2 kV in common mode ● PoE switch: ± 1 kV in common mode
	Power supply protection	<ul style="list-style-type: none"> ● AC: ± 2 kV in differential mode; ± 4 kV in common mode ● DC: ± 1 kV in differential mode; ± 2 kV in common mode
Dimensions (W x D x H)		442.0 mm x 420.0 mm x 43.6 mm
Weight	Fully loaded	≤ 8.5 kg
	Empty loaded	≤ 5 kg
Stack port		Two stack ports of the stack card
RPS		Not supported
PoE		The PWR series support PoE.
Input DC voltage	Rated input voltage range	-48 V DC to -60 V DC

Item		Description
	Maximum voltage range	-36 V DC to -72 V DC
Input AC voltage	Rated input voltage range	100 V AC to 240 V AC; 50/60 Hz
	Maximum voltage range	90 V AC to 264 V AC; 47 Hz to 63 Hz
Maximum power consumption (100% throughput, 100% PoE loads, full speed of fans)		<ul style="list-style-type: none"> ● S5700-28C-EI: 60 W ● S5700-52C-EI: 88 W ● S5700-28C-EI-24S: 63 W ● S5700-28C-PWR-EI: 842 W (power consumption: 102 W; PoE: 740 W) ● S5700-52C-PWR-EI: 930 W (power consumption: 190 W; PoE: 740 W)
Temperature	Operating temperature	0°C to +50°C
	Storage temperature	-40°C to +70°C
Noise under normal temperature (23°C, Sound Power)		<ul style="list-style-type: none"> ● S5700-28C-EI: less than 41 dBA ● S5700-52C-EI: less than 41 dBA ● S5700-28C-EI-24S: less than 41 dBA ● S5700-28C-PWR-EI: less than 45 dBA ● S5700-52C-PWR-EI: less than 45 dBA
Relative humidity		10% RH to 90% RH, non-condensing
Operating altitude		0 m to 2000 m

Item	Description
EMC	<ul style="list-style-type: none"> ● CISPR22 Class A ● CISPR24 ● EN55022 Class A ● EN50024 ● ETSI EN 300 386 Class A ● CFR 47 FCC Part 15 Class A ● ICES 003 Class A ● AS/NZS CISPR22 Class A ● IEC61000-4-2 ● ITU-T K 20 ● ITU-T K 44
Environmental standard	<ul style="list-style-type: none"> ● RoHS ● REACH
Security	<ul style="list-style-type: none"> ● IEC 60950-1 ● EN 60950-1/A11/A12 ● UL 60950-1 ● CSA C22.2 No 60950-1 ● AS/NZS 60950.1
Laser safety	<ul style="list-style-type: none"> ● IEC60825-1 ● IEC60825-2 ● EN60825-1 ● EN60825-2

2.7 S5700-HI

2.7.1 Version Mapping

Table 2-58 lists the mapping between the S5700-HI chassis and software versions.

Table 2-58 Mapping between the S5700-HI chassis and software versions

Series	Model	Available Version
S5700-HI	S5700-28C-HI	V100R006C01 and later versions
	S5700-28C-HI-24S	V100R006C01 and later versions

2.7.2 Appearance and Structure

Front View

Table 2-59 shows the front view of the S5700-HI chassis.

Table 2-59 Front view of the S5700-HI chassis

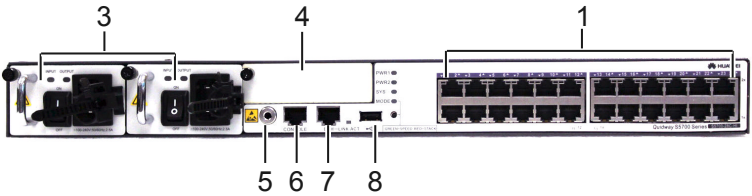
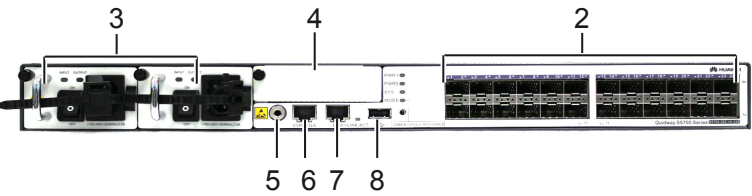
Model	Image
S5700-28C-HI	
S5700-28C-HI-24S	

1. Forty-eight 10/100/1000BASE-T Ethernet electrical ports	2. Twenty-four 100/1000BASE-X Ethernet optical ports NOTE The ports support the 1000BASE-T SFP copper module.	3. Power module slot NOTE Available power modules: <ul style="list-style-type: none"> ● 170 W AC Power Module ● 170 W DC Power Module 	4. Front card slot NOTE For details about the mapping between cards and the switch, see Cards .
5. ESD jack NOTE When you install or maintain an S5700-HI chassis, wear an ESD wrist strap and insert the other end of the ESD wrist strap into this ESD jack.	6. One console port	7. One ETH management port	8. One USB port NOTE The USB port is used to connect USB disks for deployment, configuration file transfer, and file upgrade.

Rear View

Table 2-60 shows the rear view of the S5700-HI chassis.

Table 2-60 Rear view of the S5700-HI chassis

Model	Image
S5700-28C-HI S5700-28C-HI-24S	

1. Ground screw NOTE It is used with a ground cable .	2. Monitoring port NOTE The monitoring port monitors the cabinet door, power module, battery power, and power supply of the air conditioner.	-	-
---	---	---	---

2.7.3 Indicator Description

S5700-28C-HI

 **NOTE**

Symbols and meanings of indicators on the S5700-28C-HI-24S are the same as those on the S5700-28C-HI.

Figure 2-26 Indicators on the S5700-28C-HI

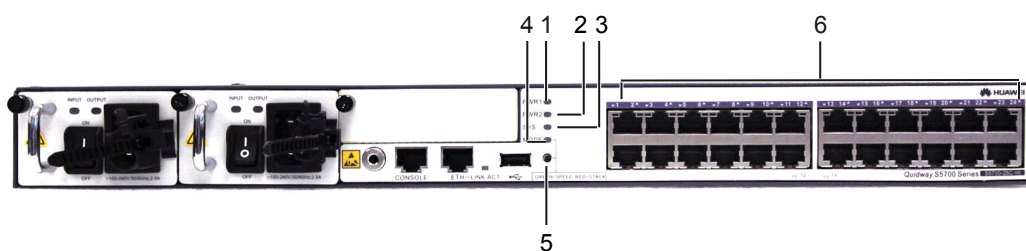

Table 2-61 Description of indicators on the S5700-28C-HI

Number	Indicator/ Button	Color	Description
1	PWR1: power supply indicator	Off	The PWR1 slot has no power module installed, or the power module is faulty when a single power module is used.

Number	Indicator/ Button	Color	Description
		Green	Steady on: The power module is working properly.
		Red	Steady on: Any of the following situations occur: <ul style="list-style-type: none">● Dual power modules are installed, but not switched on.● Dual power modules are installed, but receive no input power.● The power modules are faulty.
2	PWR2: power supply indicator	Off	The PWR2 slot has no power module installed, or the power module is faulty when a single power module is used.
		Green	Steady on: The power module is working properly.
		Red	Steady on: Any of the following situations occur: <ul style="list-style-type: none">● Dual power modules are installed, but not switched on.● Dual power modules are installed, but receive no input power.● The power modules are faulty.
3	SYS: system status indicator	Off	The system is not running.
		Green	<ul style="list-style-type: none">● Steady on: The system is not operating properly or is starting.● Blinking once every 2s (0.5 Hz): The system is operating properly.● Blinking once every 0.25s (4 Hz): The system is copying the system software and configuration file from a USB flash drive.
		Orange	<ul style="list-style-type: none">● Steady on: The system is performing self-check during startup.● Blinking once every 2s (0.5 Hz): The system has been successfully upgraded using a USB flash drive and the switch has restarted. You can remove the USB flash drive from the switch.

Number	Indicator/ Button	Color	Description
		Red	<ul style="list-style-type: none"> ● Steady on: After registering, the system does not operate properly, or a fan alarm, or temperature alarm is generated. ● Blinking once every 0.25s (4 Hz): An error occurred during USB-based upgrade and the system failed to be upgraded after a USB flash drive is inserted.
4	MODE: mode indicator	Off	The service port indicators are in the default mode (STAT).
		Green	Steady on: The service port indicators indicate the port speed. After 45 seconds, the service port indicators automatically restore to STAT mode.
5	Mode switch button	-	<ul style="list-style-type: none"> ● When you press the button once, the mode indicator turns green and the service port indicators show the speed of each port. ● When you press the button for a second time, the mode indicator turns off. <p>If you do not press the button within 45 seconds, the mode indicator restores to STAT mode.</p>
6	Service port indicator	The meaning of the service port indicator varies with the current mode. For details, see Table 2-62 and Table 2-63 .	

Table 2-62 Description of service port indicators in different modes (electrical port)

Display Mode	Color	Meaning
STAT mode	Off	The port is not connected or has been shut down.
	Green	<ul style="list-style-type: none"> ● Steady on: The port is connected. ● Blinking: The port is sending or receiving data.
SPED mode	Off	The port is not connected or has been shut down.

Display Mode	Color	Meaning
	Green	<ul style="list-style-type: none"> ● Steady on: 10M/100M/1000M port: The port is operating at a speed of 10/100 Mbit/s. 1000M/10GE port: The port is operating at a speed of 1000 Mbit/s. ● Blinking: 10M/100M/1000M port: The port is operating at a speed of 1000 Mbit/s. 1000M/10GE port: The port is operating at a speed of 10 Gbit/s.

Table 2-63 Description of service port indicators in different modes (optical port)

Display Mode	Color	Meaning
STAT mode	Off	The port is not connected or has been shut down.
	Green	Steady on: The port is connected.
	Yellow	Blinking: The port is sending or receiving data.
SPED mode	Off	The port is not connected or has been shut down.
	Green and yellow	<ul style="list-style-type: none"> ● Both steady on: 10M/100M/1000M port: The port is operating at a speed of 10/100 Mbit/s. 1000M/10GE port: The port is operating at a speed of 1000 Mbit/s. ● Both blinking: 10M/100M/1000M port: The port is operating at a speed of 1000 Mbit/s. 1000M/10GE port: The port is operating at a speed of 10 Gbit/s.

2.7.4 Port Description

10/100/1000BASE-T Ethernet Electrical Port

A 10/100/1000BASE-T Ethernet electrical port receives and sends services at a speed of 10/100/1000 Mbit/s. The ports must use **network cables**. [Table 2-64](#) describes the attributes of a 10/100/1000BASE-T Ethernet electrical port.

Table 2-64 Attributes of a 10/100/1000BASE-T Ethernet electrical port

Attribute	Description
Connector type	RJ45
Standards compliance	IEEE802.3, IEEE802.3u, IEEE802.3ab
Electrical port	MDI/MDIX NOTE <ul style="list-style-type: none">● A medium dependent interface (MDI) describes the interface (both physical and electrical) in a computer network from a physical layer implementation to the physical medium used to carry the transmission. The Ethernet ports of most NICs are MDIs.● An MDIX (for MDI crossover) is a version of MDI that enables connection between like devices. MDIX ports are usually used on hubs or LAN switches.
Frame format	Ethernet_II, Ethernet_SAP, Ethernet_SNAP
Network protocol	IP
Working mode	10/100/1000 Mbit/s auto-sensing Full duplex
Maximum transmission distance	100 m

100/1000BASE-X Ethernet Optical Port

A 100/1000BASE-X Ethernet optical port receives and sends services at a speed of 100/1000 Mbit/s. [Table 2-65](#) describes the attributes of a 100/1000BASE-X Ethernet optical port.

Table 2-65 Attributes of a 100/1000BASE-X Ethernet optical port

Attribute	Description
Connector type	LC/PC
Optical port attribute	Depending on the optical module used on the port (see SFP/eSFP Modules)
Standards compliance	IEEE802.3z
Frame format	Ethernet_II, Ethernet_SAP, Ethernet_SNAP
Network protocol	IP
Working mode	100/1000 Mbit/s auto-sensing Full duplex

Console Port

The console port is connected to a console for on-site configuration. The port must use a **console cable**. The console port is used when a switch is powered on for the first time. For details about the attributes of a console port, see [Table 2-66](#).

Table 2-66 Attributes of a console port

Attribute	Description
Connector type	RJ45
Standards compliance	RS-232
Working mode	Duplex Universal Asynchronous Receiver/Transmitter (UART)
Baud rate	9600 bit/s to 115200 bit/s Default value: 9600 bit/s
Data equipment type	Data circuit-terminating equipment (DCE)

ETH Management Port

An ETH management port is connected to the network port of a configuration terminal or network management workstation to set up the on-site or remote configuration environment. The port must use a **network cable**. [Table 2-67](#) describes the attributes of an ETH management port.

Table 2-67 Attributes of an ETH management port

Attribute	Description
Connector type	RJ45
Standards compliance	IEEE802.3
Working mode	10/100 Mbit/s auto-sensing Full duplex
Maximum transmission distance	100 m

2.7.5 Power Supply

Power Supply Configuration

On the S5700-HI switch, one or two power modules can be configured.

When two power modules are used, they work in 1+1 backup mode to provide power for the device. An AC power module and a DC power module can be configured at the same time.

Figure 2-27 shows the power supply mode of dual DC power modules. After DC power is transmitted to the PWR module, the PWR module provides 12 V output voltage, and the motherboard provides power for the entire device.

Figure 2-27 Power supply mode of dual DC power modules

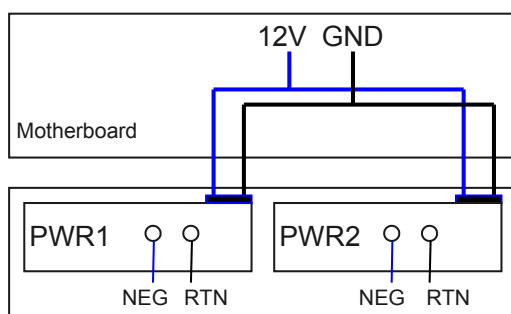

NEG: Power cable

RTN: Power return cable

GND: 12 V reference ground

Figure 2-28 shows the power supply mode of dual non-PoE AC power modules. After AC power is transmitted to the PWR module, the PWR module provides 12 V output voltage, and the motherboard provides power for the entire device.

Figure 2-28 Power supply mode of dual non-PoE AC power modules

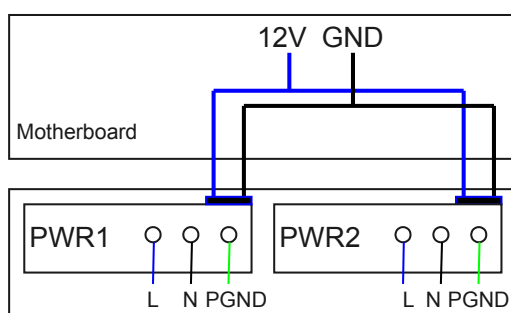

L: Live wire

N: Neutral wire

PGND: Protective ground wire

GND: 12 V reference ground

2.7.6 Heat Dissipation

Table 2-68 describes the heat dissipation modes of the S5700-HI.

Table 2-68 S5700-HI heat dissipation mode

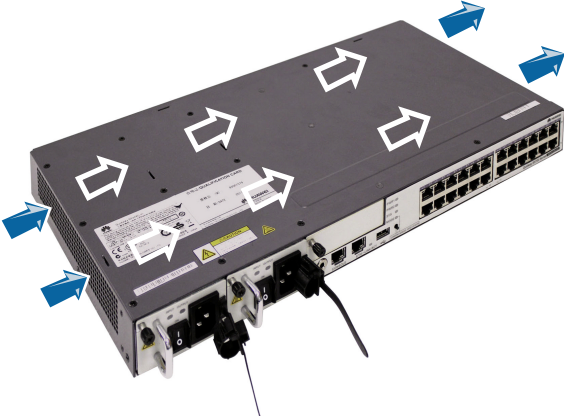
Heat Dissipation Mode	Model	Air Flow in the Chassis
Forcible heat dissipation	<ul style="list-style-type: none"> ● S5700-28C-HI ● S5700-28C-HI-24S 	<p>The air flows in from the left and flows out from the right.</p> 

2.7.7 Specifications

Table 2-69 lists specifications of the S5700-HI.

Table 2-69 Specifications of the S5700-HI

Item	Description
CPU	1 GHz dominant frequency
Packet forwarding capacity Switching capacity	<ul style="list-style-type: none"> ● S5700-28C-HI: 96 Mpps, 212 Gbit/s ● S5700-28C-HI-24S: 96 Mpps, 212 Gbit/s
DDR memory	512 MB
Flash memory	64 MB
Mean time between failures (MTBF)	<ul style="list-style-type: none"> ● S5700-28C-HI: 28.7 years when a 4x10GE card is configured; 41.1 years when a 2x10GE card is configured; 42.9 years when a 4xGE card is configured ● S5700-28C-HI-24S: 25.5 years when a 4x10GE card is configured; 34.8 years when a 2x10GE card is configured; 36.1 years when a 4xGE card is configured

Item		Description
Mean time to repair (MTTR)		2 hours
Availability		> 0.99999
Surge protection	Service port protection	Common mode: ± 2 kV
	Power supply protection	<ul style="list-style-type: none"> ● AC: ± 6 kV in differential mode; ± 6 kV in common mode ● DC: ± 1 kV in differential mode; ± 2 kV in common mode
Dimensions (W x D x H)		442.0 mm x 220.0 mm x 43.6 mm
Weight	Fully loaded	≤ 6.5 kg
	Empty loaded	≤ 5 kg
Stack port		Not supported
RPS		Not supported
PoE		Not supported
Input DC voltage	Rated input voltage range	-48 V DC to -60 V DC
	Maximum voltage range	-36 V DC to -72 V DC
Input AC voltage	Rated input voltage range	100 V AC to 240 V AC; 50/60 Hz
	Maximum voltage range	90 V AC to 264 V AC; 47 Hz to 63 Hz
Maximum power consumption (100% throughput, full speed of fans)		<ul style="list-style-type: none"> ● S5700-28C-HI: 76.6 W ● S5700-28C-HI-24S: 80.7 W

Item		Description
Temperature	Operating temperature	-5°C to +55°C (at 0 m to 1800 m altitude) NOTE <ul style="list-style-type: none"> ● When the switch has the 40 km SFP+ optical module installed, the operating temperature range is -5°C to +50°C. ● When the altitude is between 1800 m and 4000 m, the operating temperature reduces 1°C every time the altitude increases 220 m.
	Storage temperature	-40°C to +70°C
Noise under normal temperature (23°C, Sound Power)		Less than 60 dBA
Relative humidity		10% RH to 90% RH, non-condensing
Operating altitude		0 m to 4000 m
EMC		<ul style="list-style-type: none"> ● CISPR22 Class A ● CISPR24 ● EN55022 Class A ● EN50024 ● ETSI EN 300 386 Class A ● CFR 47 FCC Part 15 Class A ● ICES 003 Class A ● AS/NZS CISPR22 Class A ● IEC61000-4-2 ● ITU-T K 20 ● ITU-T K 44
Environmental standard		<ul style="list-style-type: none"> ● RoHS ● REACH
Security		<ul style="list-style-type: none"> ● IEC 60950-1 ● EN 60950-1/A11/A12 ● UL 60950-1 ● CSA C22.2 No 60950-1 ● AS/NZS 60950.1
Laser safety		<ul style="list-style-type: none"> ● IEC60825-1 ● IEC60825-2 ● EN60825-1 ● EN60825-2

2.8 S5710-EI

2.8.1 Version Mapping

Table 2-70 lists the mapping between the S5710-EI chassis and software versions.

Table 2-70 Mapping between the S5710-EI chassis and software versions

Series	Model	Available Version
S5710-EI	S5710-28C-EI	V200R001C00 and later versions
	S5710-52C-EI	V200R001C00 and later versions
	S5710-28C-PWR-EI-AC	V200R002C00 and later versions
	S5710-52C-PWR-EI-AC	V200R002C00 and later versions
	S5710-52C-PWR-EI	V200R002C00 and later versions

2.8.2 Appearance and Structure

Front View

Table 2-71 shows the front view of the S5710-EI chassis.

Table 2-71 Front view of the S5710-EI chassis

Model	Image
S5710-28C-EI	
S5710-52C-EI	

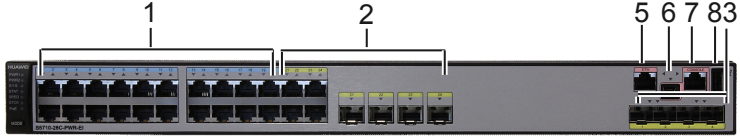
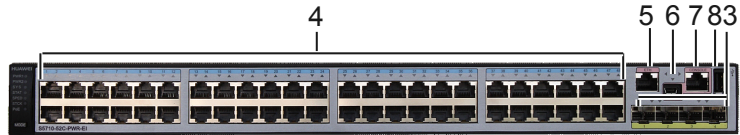
Model	Image
S5710-28C-PWR-EI-AC	
S5710-52C-PWR-EI-AC S5710-52C-PWR-EI	

1. Twenty 10/100/1000BASE-T Ethernet electrical ports	2. Four 1000M combo ports	3. Four 10GE SFP+ Ethernet optical ports	4. Forty-eight 10/100/1000BASE-T Ethernet electrical ports
5. One ETH management port	6. One Mini USB port	7. One console port	8. One USB port NOTE The USB port is used to connect USB disks for deployment, configuration file transfer, and file upgrade.



NOTE

The S5710-52C-PWR-EI and S5710-52C-PWR-EI-AC have the same appearance and provide the same functions. The S5710-52C-PWR-EI-AC is sold with a 580 W built-in power module, but the S5710-52C-PWR-EI is sold without a power module.

Rear View

Table 2-72 shows the rear view of the S5710-EI chassis.

Table 2-72 Rear view of the S5710-EI chassis

Model	Image
S5710-28C-EI S5710-52C-EI	

Model	Image
S5710-28C-PWR-EI-AC S5710-52C-PWR-EI-AC S5710-52C-PWR-EI	

1. Ground screw NOTE It is used with a ground cable .	2. Rear card slot NOTE For details about the mapping between cards and the switch, see Cards .	3. Power module slot NOTE Power modules supported by the non-PoE switch: <ul style="list-style-type: none"> ● 150 W AC Power Module ● 150 W DC Power Module Power modules supported by the PoE switch: <ul style="list-style-type: none"> ● 580 W AC PoE Power Module ● 1150 W AC PoE Power Module (supported only on the S5710-52C-PWR-EI) 	-
--	---	--	---

2.8.3 Indicator Description

S5710-28C-EI

 **NOTE**

Symbols and meanings of indicators on the S5710-52C-EI are the same as those on the S5710-28C-EI.

Figure 2-29 Indicators on the S5710-28C-EI

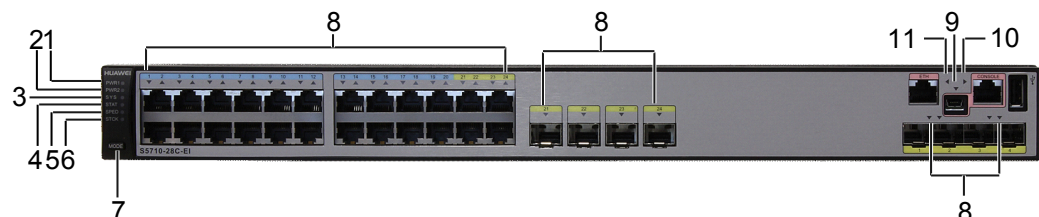

Table 2-73 Description of indicators on the S5710-28C-EI

Number	Indicator	Color	Description
1	PWR1: power supply indicator	Off	The PWR1 slot has no power module installed, or the power module is faulty when a single power module is used.
		Green	Steady on: The power module is working properly.
		Yellow	Steady on: Any of the following situations occur: <ul style="list-style-type: none"> ● Dual power modules are installed, but not switched on. ● Dual power modules are installed, but receive no input power. ● The power modules are faulty.
2	PWR2: power supply indicator	Off	The PWR2 slot has no power module installed, or the power module is faulty when a single power module is used.
		Green	Steady on: The power module is working properly.
		Yellow	Steady on: Any of the following situations occur: <ul style="list-style-type: none"> ● Dual power modules are installed, but not switched on. ● Dual power modules are installed, but receive no input power. ● The power modules are faulty.
3	SYS: system status indicator	Off	The system is not running.
		Green	<ul style="list-style-type: none"> ● Blinking once every 0.25s (4 Hz): The system is starting or is copying the system software and configuration file from a USB flash drive. ● Blinking once every 2s (0.5 Hz): The system is operating properly.
		Yellow	Blinking once every 2s (0.5 Hz): The system has been successfully upgraded using a USB flash drive and the switch has restarted. You can remove the USB flash drive from the switch.

Number	Indicator	Color	Description
		Red	<ul style="list-style-type: none"> ● Steady on: The system cannot start normally, or a temperature alarm or fan alarm is generated. ● Blinking once every 0.25s (4 Hz): An error occurred during USB-based upgrade and the system failed to be upgraded after a USB flash drive is inserted.
4	STAT: status indicator in STAT mode	Off	The STAT mode is not selected.
		Green	Steady on: The service port indicators are in the default mode (STAT).
5	SPED: status indicator in speed mode	Off	The SPED mode is not selected.
		Green	Steady on: The service port indicators indicate the port speed. After 45 seconds, the service port indicators automatically restore to STAT mode.
6	STCK: status indicator in stack mode	Off	The STAT mode is not selected.
		Green	<ul style="list-style-type: none"> ● Steady on: The service port indicators indicate the stack information. After 45 seconds, the service port indicators automatically restore to STAT mode. ● Blinking: The indicator indicates the active switch in a stack or a switch not in any stack.
7	MODE: mode switch button	-	<ul style="list-style-type: none"> ● When you press the button once, the SPED indicator turns green and the service port indicators show the speed of each port. ● When you press the button for a second time, the STCK indicator turns green and the service port indicators show the stack status. ● When you press the button for a third time, the STAT indicator turns green. <p>If you do not press the button within 45 seconds, the indicators restore to the default status. That is, the STAT indicator turns green, and the SPED and STCK indicators are off.</p>

Number	Indicator	Color	Description
8	Service port indicator <ul style="list-style-type: none"> ● GE electrical ports: The first indicator shows the status of the bottom left port. The indicators correspond to the ports from bottom to top and from left to right. ● GE/10GE optical port: Each optical port has a corresponding indicator above it. 		The meaning of the service port indicator varies with the current mode. For details, see Table 2-75 .
9	Mini USB indicator	Off	The Mini USB port is not active, and the console port is active.
		Green	Steady on: The Mini USB port is active. When this LED is on, the console port LED is off.
10	Console indicator	Off	The console port is not active, and the Mini USB port is active.
		Green	Steady on (default): The console port is active. When this LED is on, the Mini USB port LED is off.
11	ETH indicator	Off	The port is not connected.
		Green	<ul style="list-style-type: none"> ● Steady on: The port is connected. ● Blinking: The port is sending or receiving data.

S5710-28C-PWR-EI-AC

NOTE

Symbols and meanings of indicators on the S5710-52C-PWR-EI and the S5710-52C-PWR-EI-AC are the same as those on the S5710-28C-PWR-EI-AC.

Figure 2-30 Indicators on the S5710-28C-PWR-EI-AC

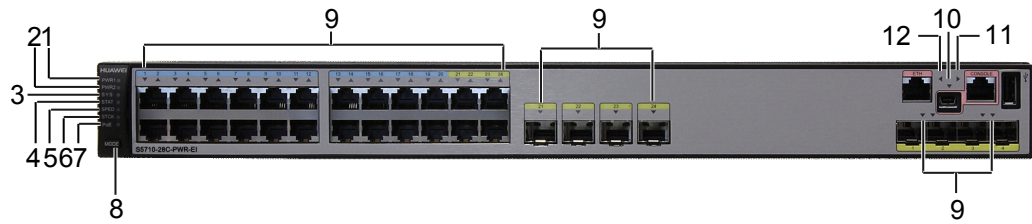

Table 2-74 Description of indicators on the S5710-28C-PWR-EI-AC

Number	Indicator	Color	Description
1	PWR1: power supply indicator	Off	The PWR1 slot has no power module installed, or the power module is faulty when a single power module is used.
		Green	Steady on: The power module is working properly.
		Yellow	Steady on: Any of the following situations occur: <ul style="list-style-type: none"> ● Dual power modules are installed, but not switched on. ● Dual power modules are installed, but receive no input power. ● The power modules are faulty.
2	PWR2: power supply indicator	Off	The PWR2 slot has no power module installed, or the power module is faulty when a single power module is used.
		Green	Steady on: The power module is working properly.
		Yellow	Steady on: Any of the following situations occur: <ul style="list-style-type: none"> ● Dual power modules are installed, but not switched on. ● Dual power modules are installed, but receive no input power. ● The power modules are faulty.
3	SYS: system status indicator	Off	The system is not running.

Number	Indicator	Color	Description
		Green	<ul style="list-style-type: none"> ● Blinking once every 0.25s (4 Hz): The system is starting or is copying the system software and configuration file from a USB flash drive. ● Blinking once every 2s (0.5 Hz): The system is operating properly.
		Yellow	Blinking once every 2s (0.5 Hz): The system has been successfully upgraded using a USB flash drive and the switch has restarted. You can remove the USB flash drive from the switch.
		Red	<ul style="list-style-type: none"> ● Steady on: The system cannot start normally, or a temperature alarm or fan alarm is generated. ● Blinking once every 0.25s (4 Hz): An error occurred during USB-based upgrade and the system failed to be upgraded after a USB flash drive is inserted.
4	STAT: status indicator in STAT mode	Off	The STAT mode is not selected.
		Green	Steady on: The service port indicators are in the default mode (STAT).
5	SPED: status indicator in speed mode	Off	The SPED mode is not selected.
		Green	Steady on: The service port indicators indicate the port speed. After 45 seconds, the service port indicators automatically restore to STAT mode.
6	STCK: status indicator in stack mode	Off	The STAT mode is not selected.
		Green	<ul style="list-style-type: none"> ● Steady on: The service port indicators indicate the stack information. After 45 seconds, the service port indicators automatically restore to STAT mode. ● Blinking: The indicator indicates the active switch in a stack or a switch not in any stack.
7	PoE: PoE indicator	Off	The PoE mode is not selected.
		Green	Steady on: The service port indicators indicate the PoE status. After 45 seconds, the service port indicators automatically restore to STAT mode.

Number	Indicator	Color	Description
8	MODE: mode switch button	-	<ul style="list-style-type: none"> When you press the button once, the SPED indicator turns green and the service port indicators show the speed of each port. When you press the button for a second time, the STCK indicator turns green and the service port indicators show the stack status. When you press the button for a third time, the STCK indicator turns green and the service port indicators show the stack status. When you press the button for a fourth time, the STAT indicator turns green. <p>If you do not press the button within 45 seconds, the indicators restore to the default status. That is, the STAT indicator turns green, and the SPED, STCK, and PoE indicators are off.</p>
9	<p>Service port indicator</p> <ul style="list-style-type: none"> GE electrical ports: The first indicator shows the status of the bottom left port. The indicators correspond to the ports from bottom to top and from left to right. GE/10GE optical port: Each optical port has a corresponding indicator above it. 	The meaning of the service port indicator varies with the current mode. For details, see Table 2-75 .	
10	Mini USB indicator	Off	The Mini USB port is not active, and the console port is active.

Number	Indicator	Color	Description
		Green	Steady on: The Mini USB port is active. When this LED is on, the console port LED is off.
11	Console indicator	Off	The console port is not active, and the Mini USB port is active.
		Green	Steady on (default): The console port is active. When this LED is on, the Mini USB port LED is off.
12	ETH indicator	Off	The port is not connected.
		Green	<ul style="list-style-type: none"> ● Steady on: The port is connected. ● Blinking: The port is sending or receiving data.

Table 2-75 Description of service port indicators in different modes

Display Mode	Color	Meaning
STAT mode	Off	The port is not connected or has been shut down.
	Green	<ul style="list-style-type: none"> ● Steady on: The port is connected. ● Blinking: The port is sending or receiving data.
SPED mode	Off	The port is not connected or has been shut down.
	Green	<ul style="list-style-type: none"> ● Steady on: <ul style="list-style-type: none"> 10M/100M/1000M port: The port is operating at a speed of 10/100 Mbit/s. 1000M/10GE port: The port is operating at a speed of 1000 Mbit/s. ● Blinking: <ul style="list-style-type: none"> 10M/100M/1000M port: The port is operating at a speed of 1000 Mbit/s. 1000M/10GE port: The port is operating at a speed of 10 Gbit/s.
PoE mode	Off	The port does not provide PoE power.
	Green	Steady on: The port is providing PoE power.

Display Mode	Color	Meaning
	Yellow	<ul style="list-style-type: none"> ● Steady on: The PoE function is disabled on the port. ● Blinking: A PoE fault has occurred. For example, an incompatible PD is connected to the port.
	Green and yellow	<p>Blinking green and yellow alternately: The port cannot provide power to a PD. The possible reasons including:</p> <ul style="list-style-type: none"> ● The power of a connected PD exceeds the port's power supply capability or upper power threshold. ● The power provided by the switch has reached the power supply capability of the switch. ● The switch is not enabled to provide power for PDs.
STCK mode	Off	Port indicators do not show the stack ID of the switch.
	Green	<ul style="list-style-type: none"> ● Steady on: The switch is not a master switch: <ul style="list-style-type: none"> - If the indicator of a port is steady on, the number of this port is the stack ID of the switch. - If the first nine port indicators of the switch are steady on, the stack ID of the switch is 0. ● Blinking: The switch is a master switch: <ul style="list-style-type: none"> - If the indicator of a port is blinking, the number of this port is the stack ID of the switch. - If the first nine port indicators of the switch are blinking, the stack ID of the switch is 0.

2.8.4 Port Description

10/100/1000BASE-T Ethernet Electrical Port

A 10/100/1000BASE-T Ethernet electrical port receives and sends services at a speed of 10/100/1000 Mbit/s. The ports must use **network cables**. [Table 2-76](#) describes the attributes of a 10/100/1000BASE-T Ethernet electrical port.

Table 2-76 Attributes of a 10/100/1000BASE-T Ethernet electrical port

Attribute	Description
Connector type	RJ45
Standards compliance	IEEE802.3, IEEE802.3u, IEEE802.3ab
Electrical port	MDI/MDIX NOTE <ul style="list-style-type: none">● A medium dependent interface (MDI) describes the interface (both physical and electrical) in a computer network from a physical layer implementation to the physical medium used to carry the transmission. The Ethernet ports of most NICs are MDIs.● An MDIX (for MDI crossover) is a version of MDI that enables connection between like devices. MDIX ports are usually used on hubs or LAN switches.
Frame format	Ethernet_II, Ethernet_SAP, Ethernet_SNAP
Network protocol	IP
Working mode	10/100/1000 Mbit/s auto-sensing Full duplex
Maximum transmission distance	100 m

Combo Port

A combo port consists of an optical Ethernet port and an electrical Ethernet port on the panel. Each combo port matches only one internal forwarding port. A combo port is a multiplexing port, and you can use either the optical port or electrical port at one time. When one of the Ethernet ports is used, the other port is disabled.

NOTE

By default, a combo port works in the auto mode. In the auto mode, if the electrical port is connected to a network cable first, the combo port works as an electrical port to transmit data; if the optical port is connected to a fiber first, the combo port works as an optical port to transmit data. When both optical port and electrical port are connected, the optical port takes the priority. You can run the **combo-port** command to set the working mode of the combo port.

10GE SFP+ Ethernet Optical Port

A 10GE SFP+ Ethernet optical port supports auto-sensing to 1000 Mbit/s. It receives and sends services at a speed of 1000/10000 Mbit/s. The ports must be used with **optical modules** and **optical fibers**. [Table 2-77](#) describes the attributes of a 10GE SFP+ Ethernet optical port.

Table 2-77 Attributes of a 10GE SFP+ Ethernet optical port

Attribute	Description
Connector type	LC/PC
Optical port attribute	Depending on the optical module used on the port (see 7.3 SFP+ Modules)
Standards compliance	IEEE802.3ae
Frame format	Ethernet_II, Ethernet_SAP, Ethernet_SNAP
Network protocol	IP
Working mode	GE/10GE auto-sensing Full duplex

Console Port

The console port is connected to a console for on-site configuration. The port must use a [console cable](#). The console port is used when a switch is powered on for the first time. For details about the attributes of a console port, see [Table 2-78](#).

Table 2-78 Attributes of a console port

Attribute	Description
Connector type	RJ45
Standards compliance	RS-232
Working mode	Duplex Universal Asynchronous Receiver/Transmitter (UART)
Baud rate	9600 bit/s to 115200 bit/s Default value: 9600 bit/s
Data equipment type	Data circuit-terminating equipment (DCE)

Mini USB Port

The Mini USB port can connect to a console for onsite configuration of the system. The Mini USB port and console port cannot be used together. Select one as required. The Mini USB port is recommended.

ETH Management Port

An ETH management port is connected to the network port of a configuration terminal or network management workstation to set up the on-site or remote configuration environment.

The port must use a **network cable**. [Table 2-79](#) describes the attributes of an ETH management port.

Table 2-79 Attributes of an ETH management port

Attribute	Description
Connector type	RJ45
Standards compliance	IEEE802.3
Working mode	10/100 Mbit/s auto-sensing Full duplex
Maximum transmission distance	100 m

2.8.5 Power Supply

PoE Power Supply Configuration

Currently, the S5710-52C-PWR-EI, S5710-28C-PWR-EI-AC and S5710-52C-PWR-EI-AC support PoE power supply.

The PoE switch provides two power module slots, each supporting a 580 W power module or a 1150 W power module. A single power module provides 370 W or 740 W PoE power for the PDs. The power supply configurations are shown in [Table 2-80](#).

Table 2-80 Power supply configurations

Power Module		PoE Power	Device	Maximum Number of Ports (Fully Loaded)
580 W	-	370 W	<ul style="list-style-type: none">● S5710-28C-PWR-EI-AC● S5710-52C-PWR-EI-AC● S5710-52C-PWR-EI	<ul style="list-style-type: none">● 802.3af (15.4 W per port): 24● 802.3at (30 W per port): 12
580 W	580 W	740 W	<ul style="list-style-type: none">● S5710-52C-PWR-EI-AC● S5710-52C-PWR-EI	<ul style="list-style-type: none">● 802.3af (15.4 W per port): 48● 802.3at (30 W per port): 24

Power Module		PoE Power	Device	Maximum Number of Ports (Fully Loaded)
			S5710-28C-PWR-EI-AC	<ul style="list-style-type: none"> ● 802.3af (15.4 W per port): 24 ● 802.3at (30 W per port): 24
1150 W	-	785.4 W	S5710-52C-PWR-EI	<ul style="list-style-type: none"> ● 802.3af (15.4 W per port): 48 ● 802.3at (30 W per port): 26
1150 W	1150 W	1570.8 W	S5710-52C-PWR-EI	<ul style="list-style-type: none"> ● 802.3af (15.4 W per port): 48 ● 802.3at (30 W per port): 48



NOTE

When two power modules are used, they work in redundancy mode to provide power for the switch and in load balancing mode to provide power for the PDs.

Figure 2-31 shows the power supply mode of a PoE AC power module. After AC power is transmitted to the PWR module, the PWR module provides 12 V and -53 V output voltages, and the motherboard provides 12 V voltage for the entire device and -53 V voltage for the PDs.

Figure 2-31 Power supply mode of a PoE AC power module

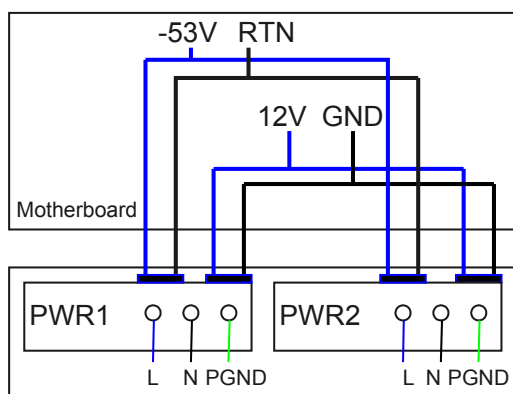

L: Live wire N: Neutral wire PGND: Protective ground wire GND: 12 V reference ground

RTN: -53 V reference ground

Non-PoE Power Supply Configuration

On the S5710-EI non-PoE switch, one or two power modules can be configured.

When two power modules are used, they work in 1+1 backup mode to provide power for the device. An AC power module and a DC power module can be configured at the same time.

Figure 2-32 shows the power supply mode of dual DC power modules. After DC power is transmitted to the PWR module, the PWR module provides 12 V output voltage, and the motherboard provides power for the entire device.

Figure 2-32 Power supply mode of dual DC power modules

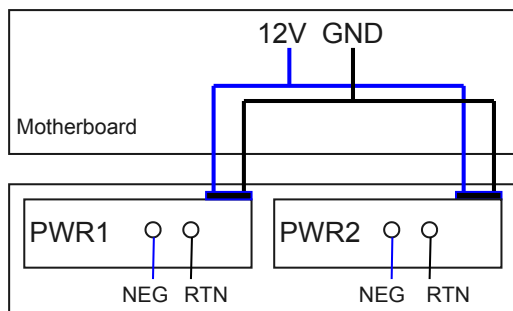

NEG: Power cable

RTN: Power return cable

GND: 12 V reference ground

Figure 2-33 shows the power supply mode of dual non-PoE AC power modules. After AC power is transmitted to the PWR module, the PWR module provides 12 V output voltage, and the motherboard provides power for the entire device.

Figure 2-33 Power supply mode of dual non-PoE AC power modules

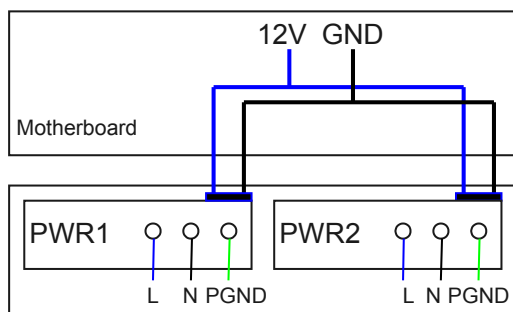

L: Live wire

N: Neutral wire

PGND: Protective ground wire

GND: 12 V reference ground

2.8.6 Heat Dissipation

Table 2-81 describes the heat dissipation modes of the S5710-EI.

Table 2-81 S5710-EI heat dissipation mode

Heat Dissipation Mode	Model	Air Flow in the Chassis
Forcible heat dissipation	<ul style="list-style-type: none"> ● S5710-28C-EI ● S5710-52C-EI ● S5710-28C-PWR-EI-AC ● S5710-52C-PWR-EI-AC ● S5710-52C-PWR-EI 	<p>The air flows in from the left and flows out from the right.</p> 

2.8.7 Specifications

Table 2-82 lists specifications of the S5710-EI.

Table 2-82 Specifications of the S5710-EI

Item	Description
CPU	1 GHz dominant frequency
Packet forwarding capacity Switching capacity	<ul style="list-style-type: none"> ● S5710-28C-EI: 156 Mpps, 208 Gbit/s ● S5710-52C-EI: 192 Mpps, 416 Gbit/s ● S5710-28C-PWR-EI-AC: 156 Mpps, 208 Gbit/s ● S5710-52C-PWR-EI-AC: 192 Mpps, 416 Gbit/s ● S5710-52C-PWR-EI: 192 Mpps, 416 Gbit/s
DDR memory	512 MB
Flash memory	200 MB

Item		Description
Mean time between failures (MTBF)		<ul style="list-style-type: none"> ● S5710-28C-EI: 55.98 years when a 8xGE optical interface subcard is configured; 54.93 years when a 8xGE electrical interface subcard is configured; 52.69 years when a 2x10GE interface subcard is configured ● S5710-52C-EI: 45.57 years when a 8xGE optical interface subcard is configured; 44.85 years when a 8xGE electrical interface subcard is configured; 43.33 years when a 2x10GE interface subcard is configured ● S5710-28C-PWR-EI-AC: 51.28 years when a 8xGE optical interface subcard is configured; 50.31 years when a 8xGE electrical interface subcard is configured; 48.25 years when a 2x10GE interface subcard is configured ● S5710-52C-PWR-EI-AC: 36.86 years when a 8xGE optical interface subcard is configured; 36.35 years when a 8xGE electrical interface subcard is configured; 35.27 years when a 2x10GE interface subcard is configured ● S5710-52C-PWR-EI: 36.86 years when a 8xGE optical interface subcard is configured; 36.35 years when a 8xGE electrical interface subcard is configured; 35.27 years when a 2x10GE interface subcard is configured
Mean time to repair (MTTR)		2 hours
Availability		> 0.99999
Surge protection	Service port protection	<ul style="list-style-type: none"> ● Non-PoE switch: ± 2 kV in common mode ● PoE switch: ± 1 kV in common mode
	Power supply protection	<ul style="list-style-type: none"> ● DC: ± 1 kV in differential mode; ± 2 kV in common mode ● AC: <ul style="list-style-type: none"> - S5710-28C-EI: ± 2 kV in differential mode; ± 4 kV in common mode - S5710-52C-EI: ± 2 kV in differential mode; ± 4 kV in common mode - S5710-28C-PWR-EI-AC: ± 6 kV in differential mode; ± 6 kV in common mode - S5710-52C-PWR-EI-AC: ± 6 kV in differential mode; ± 6 kV in common mode - S5710-52C-PWR-EI (using 580 W power modules): ± 6 kV in differential mode; ± 6 kV in common mode - S5710-52C-PWR-EI (using 1150 W power modules): ± 2 kV in differential mode; ± 4 kV in common mode
Dimensions (W x D x H)		442.0 mm x 420.0 mm x 43.6 mm

Item		Description
Weight	Fully loaded	≤ 10 kg
	Empty	≤ 6 kg
Stack port		Four 10GE SFP+ ports or two 10GE SFP+ rear card ports
RPS		Not supported
PoE		The PWR series support PoE.
Input DC voltage	Rated input voltage range	-48 V DC to -60 V DC
	Maximum voltage range	-36 V DC to -72 V DC
Input AC voltage	Rated input voltage range	100 V AC to 240 V AC; 50/60 Hz
	Maximum voltage range	90 V AC to 264 V AC; 47 Hz to 63 Hz

Item		Description
Maximum power consumption (100% throughput, 100% PoE loads, full speed of fans)		<ul style="list-style-type: none"> ● S5710-28C-EI: 98 W ● S5710-52C-EI: 146.9 W ● S5710-28C-PWR-EI-AC: <ul style="list-style-type: none"> - Without subcard: 920 W (power consumption: 180 W, PoE: 740 W) - With two 8xGE electrical interface subcards: 934 W (power consumption: 194 W, PoE: 740 W) - With two 8xGE optical interface subcards: 942 W (power consumption: 202 W, PoE: 740 W) - With two 2x10GE optical interface subcards: 941 W (power consumption: 201 W, PoE: 740 W) ● S5710-52C-PWR-EI, S5710-52C-PWR-EI-AC (with two 580 W power modules configured): <ul style="list-style-type: none"> - Without subcard: 1023 W (power consumption: 283 W, PoE: 740 W) - With two 8xGE electrical interface subcards: 1035 W (power consumption: 295 W, PoE: 740 W) - With two 8xGE optical interface subcards: 1043 W (power consumption: 303 W, PoE: 740 W) - With two 2x10GE optical interface subcards: 1040 W (power consumption: 300 W, PoE: 740 W) ● S5710-52C-PWR-EI (with two 1150 W power modules configured): <ul style="list-style-type: none"> - Without subcard: 1605 W (power consumption: 165 W, PoE: 1440 W) - With two 8xGE electrical interface subcard: 1625 W (power consumption: 185 W, PoE: 1440 W) - With two 8xGE optical interface subcard: 1635 W (power consumption: 195 W, PoE: 1440 W) - With two 2x10GE optical interface subcard: 1633 W (power consumption: 193 W, PoE: 1440 W)
Temperature	Operating temperature	0°C to +50°C (at 0 m to 1800 m altitude) NOTE When the altitude is between 1800 m and 5000 m, the operating temperature reduces 1°C every time the altitude increases 220 m.
	Storage temperature	-40°C to +70°C

Item	Description
Noise under normal temperature (23°C, Sound Power)	<ul style="list-style-type: none"> ● S5710-28C-EI: less than 53.9 dBA ● S5710-52C-EI: less than 53.9 dBA ● S5710-28C-PWR-EI-AC: less than 59.7 dBA ● S5710-52C-PWR-EI-AC: less than 60 dBA ● S5710-52C-PWR-EI: less than 60 dBA
Relative humidity	5% RH to 95% RH, non-condensing
Operating altitude	<ul style="list-style-type: none"> ● S5710-28C-EI: 0 m to 3000 m when AC power module is configured; 0 m to 2000 m when DC power module is configured ● S5710-52C-EI: 0 m to 3000 m when AC power module is configured; 0 m to 2000 m when DC power module is configured ● S5710-28C-PWR-EI-AC: 0 m to 5000 m ● S5710-52C-PWR-EI-AC: 0 m to 5000 m ● S5710-52C-PWR-EI: 0 m to 5000 m
EMC	<ul style="list-style-type: none"> ● CISPR22 Class A ● CISPR24 ● EN55022 Class A ● EN50024 ● ETSI EN 300 386 Class A ● CFR 47 FCC Part 15 Class A ● ICES 003 Class A ● AS/NZS CISPR22 Class A ● IEC61000-4-2 ● ITU-T K 20 ● ITU-T K 44
Environmental standard	<ul style="list-style-type: none"> ● RoHS ● REACH
Safety	<ul style="list-style-type: none"> ● IEC 60950-1 ● EN 60950-1/A11/A12 ● UL 60950-1 ● CSA C22.2 No 60950-1 ● AS/NZS 60950.1
Laser safety	<ul style="list-style-type: none"> ● IEC60825-1 ● IEC60825-2 ● EN60825-1 ● EN60825-2

3 Power Module

About This Chapter



CAUTION

- Only the power modules of the same power can be used on an S5700.
 - Power supply units are hot-swappable in the 1:1 scenario but it is strongly recommended to shutdown power supply unit before replacement in order to avoid electrical shock.
 - Before powering off the S5700, shut down all its power supply units.
-

[3.1 150 W AC Power Module](#)

[3.2 150 W DC Power Module](#)

[3.3 170 W AC Power Module](#)

[3.4 170 W DC Power Module](#)

[3.5 250 W AC PoE Power Module](#)

[3.6 500 W AC PoE Power Module](#)

[3.7 580 W AC PoE Power Module](#)

[3.8 1150 W AC PoE Power Module](#)

[3.9 RPS1800 Power Supply](#)

[3.10 870 W DC Power Module](#)

3.1 150 W AC Power Module

Version Mapping

Table 3-1 lists the switch chassis and software versions matching a 150 W AC power module.

Table 3-1 Switch chassis and software versions matching a 150 W AC power module

Power Module Name	S5700-SI S5700-EI	S5710-EI	S5700-LI S5700S-LI S5700-HI
150 W AC power module	Supported only by the S5700-28C-EI, S5700-28C-EI-24S, S5700-52C-EI, S5700-28C-SI, and S5700-52C-SI NOTE This module is supported in V100R005C01 and later versions.	Supported only by the S5710-28C-EI and S5710-52C-EI NOTE This module is supported in V200R001C00 and later versions.	Not supported

Appearance

Figure 3-1 shows the appearance of a 150 W AC power module.

Figure 3-1 Appearance of the 150 W AC power module



Function

Table 3-2 describes the functions of a 150 W AC power module.

Table 3-2 Functions of a 150 W AC power module

Function	Description
Input protection	Input undervoltage and overvoltage protection is provided.
Output protection	Output undervoltage, overvoltage, overcurrent, and short-circuit protection is provided.
Electromagnetic compatibility (EMC) filter	-
Overtemperature protection	-
Surge protection	-

Panel Description

Figure 3-2 shows the panel of a 150 W AC power module.

Figure 3-2 Panel of a 150 W AC power module

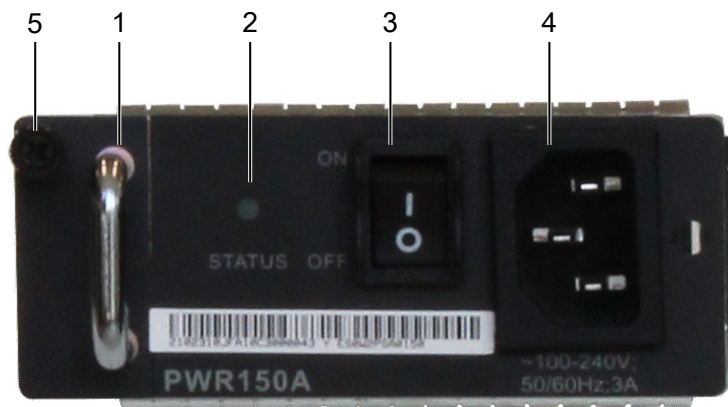

1. Handle	2. Power status indicator	3. Power switch	4. AC power socket	5. Captive screw
-----------	---------------------------	-----------------	--------------------	------------------

Table 3-3 describes the indicators on a 150 W AC power module panel.

Table 3-3 Description of indicators on a 150 W AC power module panel

Indicator	Color	Description
STATUS	Off	<ul style="list-style-type: none"> The input power is out of range, for example, no AC input power, AC input overvoltage, or AC input undervoltage. The output power is out of range, for example, undervoltage or overtemperature occurs.

Indicator	Color	Description
	Green	<ul style="list-style-type: none">● Steady on: The AC power input is in the normal range.● Blinking: The output power is out of range, for example, overvoltage, overcurrent, or short circuit occurs.

Specifications

Table 3-4 describes the technical specifications of a 150 W AC power module.

Table 3-4 Technical specifications of a 150 W AC power module

Description	Item
Dimensions (W x D x H)	100 mm x 205 mm x 40 mm
Weight	0.8 kg
Rated input voltage range	100 V AC to 240 V AC; 50/60 Hz
Maximum input voltage range	90 V AC to 264 V AC; 47 Hz to 63 Hz
Maximum input current	3 A
Maximum output current	12.5 A
Rated output voltage	12 V
Maximum output power	150 W

3.2 150 W DC Power Module

Version Mapping

Table 3-5 lists the switch chassis and software versions matching a 150 W DC power module.

Table 3-5 Switch chassis and software versions matching a 150 W DC power module

Power Module Name	S5700-SI S5700-EI	S5710-EI	S5700-LI S5700S-LI S5700-HI
150 W DC power module	Supported only by the S5700-28C-EI, S5700-28C-EI-24S, S5700-52C-EI, S5700-28C-SI, and S5700-52C-SI NOTE This module is supported in V100R005C01 and later versions.	Supported only by the S5710-28C-EI and S5710-52C-EI NOTE This module is supported in V200R001C00 and later versions.	Not supported

Appearance

Figure 3-3 shows the appearance of a 150 W DC power module.

Figure 3-3 Appearance of the 150 W DC power module

Function

Table 3-6 describes the functions of a 150 W DC power module.

Table 3-6 Functions of a 150 W DC power module

Function	Description
Alarm function	Alarms for various power supply events, such as no power input, air breaker status, ineffective surge protection, and input undervoltage are supported.
EMC filter	-

Function	Description
Short circuit	-
Surge protection	-

Panel Description

Figure 3-4 shows the panel of a 150 W DC power module.

Figure 3-4 Panel of a 150 W DC power module

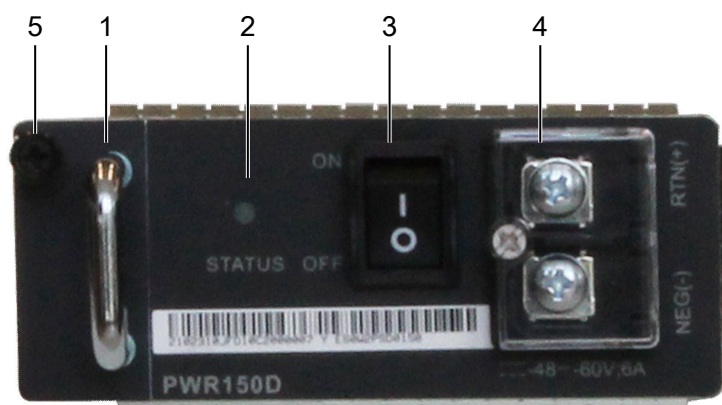

1. Handle	2. Power status indicator	3. Power switch	4. DC power terminal	5. Captive screw
-----------	---------------------------	-----------------	----------------------	------------------

Table 3-7 describes the indicators on a 150 W DC power module panel.

Table 3-7 Description of indicators on a 150 W DC power module panel

Indicator	Color	Description
STATUS	Off	<ul style="list-style-type: none"> The input power is out of range, for example, no DC input power, DC input overvoltage, or DC input undervoltage. The output power is out of range, for example, undervoltage or overtemperature occurs.
	Green	<ul style="list-style-type: none"> Steady on: The DC power input is in the normal range. Blinking: The output power is out of range, for example, overvoltage, overcurrent, or short circuit occurs.

Specifications

Table 3-8 describes the technical specifications of a 150 W DC power module.

Table 3-8 Technical specifications of a 150 W DC power module

Description	Item
Dimensions (W x D x H)	100 mm x 205 mm x 40 mm
Weight	0.8 kg
Rated input voltage range	-48 V DC to -60 V DC
Maximum input voltage range	-36 V DC to -72 V DC
Maximum input current	6 A
Maximum output current	12.5 A
Rated output voltage	12 V
Maximum output power	150 W

3.3 170 W AC Power Module

Version Mapping

Table 3-9 lists the switch chassis and software versions matching a 170 W AC power module.

Table 3-9 Switch chassis and software versions matching a 170 W AC power module

Power Module Name	S5700-HI	S5700-LI S5700S-LI S5700-SI S5700-EI S5710-EI
170 W AC power module	Supported NOTE This module is supported in V100R006C01 and later versions.	Not supported

Appearance

Figure 3-5 shows the appearance of a 170 W AC power module.

Figure 3-5 Appearance of the 170 W AC power module



Function

Table 3-10 describes the functions of a 170 W AC power module.

Table 3-10 Functions of a 170 W AC power module

Function	Description
Input protection	Input overcurrent and undervoltage protection is provided.
Output protection	Output overvoltage and short-circuit protection is provided.
Alarm function	Various alarms such as the alarm triggered when there is no power input and the alarm triggered when there is no power output are supported.
EMC filter	-
Reversed connection protection	-
Overtemperature protection	-
Surge protection	-

Panel Description

Figure 3-6 shows the panel of a 170 W AC power module.

Figure 3-6 Panel of a 170 W AC power module

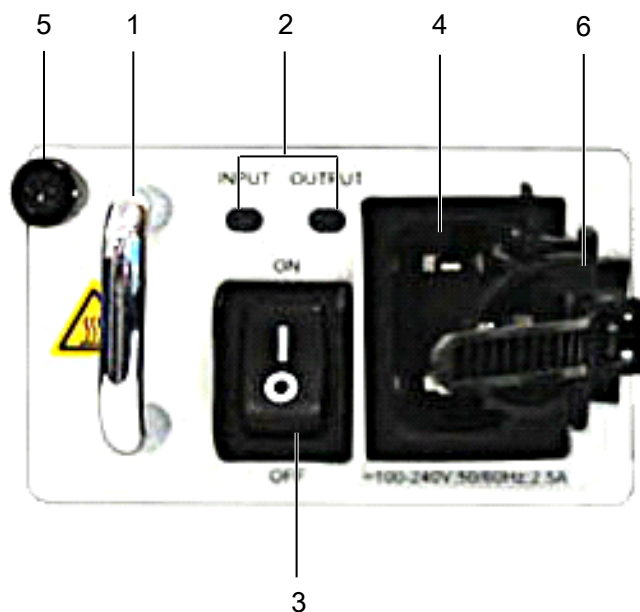

1. Handle	2. Power status indicator	3. Power switch	4. AC power socket
5. Captive screw	6. AC terminal loose-proof pinch	-	-

Table 3-11 describes the indicators on a 170 W AC power module panel.

Table 3-11 Description of indicators on a 170 W AC power module panel

Indicator	Color	Description
INPUT	Off	The AC input power is out of range.
	Green	Steady on: The AC power input is in the normal range.
OUTPUT	Off	The AC output power is out of range.
	Green	<ul style="list-style-type: none"> ● Steady on: The AC output power is in the normal range. ● Blinking: The output power is out of range, for example, overvoltage, overcurrent, or short circuit occurs.

Specifications

Table 3-12 describes the technical specifications of a 170 W AC power module.

Table 3-12 Technical specifications of a 170 W AC power module

Description	Item
Dimensions (W x D x H)	70 mm x 205 mm x 40 mm
Weight	<1.0 kg
Rated input voltage range	100 V AC to 240 V AC; 50/60 Hz
Maximum input voltage range	90 V AC to 264 V AC; 47 Hz to 63 Hz
Maximum input current	2.5 A
Maximum output current	14.2 A
Rated output voltage	12 V
Maximum output power	170 W

3.4 170 W DC Power Module

Version Mapping

Table 3-13 lists the switch chassis and software versions matching a 170 W DC power module.

Table 3-13 Switch chassis and software versions matching a 170 W DC power module

Power Module Name	S5700-HI	S5700-LI S5700S-LI S5700-SI S5700-EI S5710-EI
170 W DC power module	Supported NOTE This module is supported in V100R006C01 and later versions.	Not supported

Appearance

Figure 3-7 shows the appearance of a 170 W DC power module.

Figure 3-7 Appearance of the 170 W DC power module

Function

Table 3-14 describes the functions of a 170 W DC power module.

Table 3-14 Functions of a 170 W DC power module

Function	Description
Input protection	Input overcurrent and undervoltage protection is provided.
Output protection	Output overvoltage and short-circuit protection is provided.
Alarm function	Various alarms such as the alarm triggered when there is no power input and the alarm triggered when there is no power output are supported.
EMC filter	-
Reversed connection protection	-
Overtemperature protection	-
Surge protection	-

Panel Description

Figure 3-8 shows the panel of a 170 W DC power module.

Figure 3-8 Panel of a 170 W DC power module

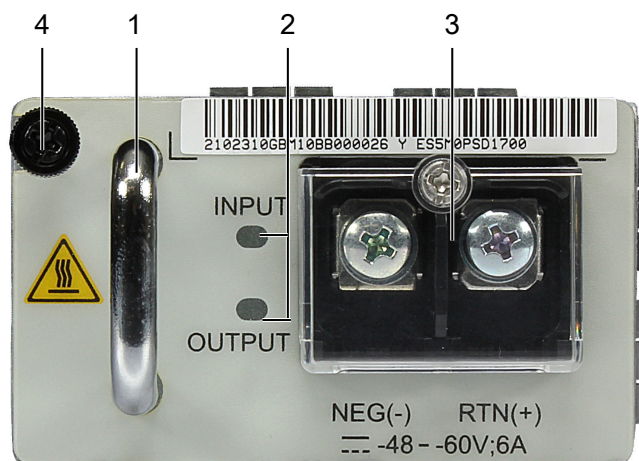

1. Handle	2. Power status indicator	3. DC power terminal	4. Captive screw
-----------	---------------------------	----------------------	------------------

Table 3-15 describes the indicators on a 170 W DC power module panel.

Table 3-15 Description of indicators on a 170 W DC power module panel

Indicator	Color	Description
INPUT	Off	The DC input power is out of range.
	Green	Steady on: The DC power input is in the normal range.
OUTPUT	Off	The DC output power is out of range.
	Green	<ul style="list-style-type: none"> Steady on: The DC output power is in the normal range. Blinking: The output power is out of range, for example, overvoltage, overcurrent, or short circuit occurs.

Specifications

Table 3-16 describes the technical specifications of a 170 W DC power module.

Table 3-16 Technical specifications of a 170 W DC power module

Description	Item
Dimensions (W x D x H)	70 mm x 205 mm x 40 mm
Weight	< 1.0 kg

Description	Item
Rated input voltage range	-48 V DC to -60 V DC
Maximum input voltage range	-36 V DC to -72 V DC
Maximum input current	6 A
Maximum output current	14.2 A
Rated output voltage	12 V
Maximum output power	170 W

3.5 250 W AC PoE Power Module

Version Mapping

Table 3-17 lists the switch chassis and software versions matching a 250 W AC PoE power module.

Table 3-17 Switch chassis and software versions matching a 250 W AC PoE power module

Power Module Name	S5700-SI S5700-EI	S5700-LI S5700S-LI S5700-HI S5710-EI
250 W AC PoE power module	Supported only by the S5700-28C-PWR-EI, S5700-52C-PWR-EI, S5700-28C-PWR-SI, S5700-52C-PWR-SI, S5700-24TP-PWR-SI, and S5700-48TP-PWR-SI NOTE This module is supported in V100R005C01 and later versions.	Not supported

Appearance

Figure 3-9 shows the appearance of a 250 W AC PoE power module.

Figure 3-10 Panel of a 250 W AC PoE power module

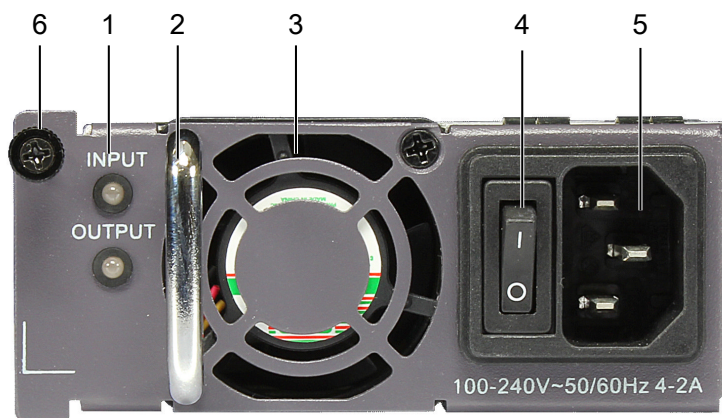

1. Power status indicator	2. Handle	3. Fan	4. Switch
5. AC power socket	6. Captive screw	-	-

Table 3-19 describes the indicators on a 250 W AC PoE power module panel.

Table 3-19 Description of indicators on a 250 W AC PoE power module panel

Indicator	Color	Description
INPUT	Off	The power cable is loose or no input AC power is provided.
	Green	Steady on: The AC input power is in the normal range.
	Red	Steady on: The AC input power is out of range, for example, undervoltage or overvoltage.
OUTPUT	Off	The power cable is loose or no input AC power is provided.
	Green	Steady on: The AC output power is in the normal range.
	Red	Steady on: The power output is out of range. <ul style="list-style-type: none"> ● Abnormal power fan operation ● Output overvoltage ● Output overcurrent ● Short circuit ● Overtemperature protection

Specifications

Table 3-20 describes the technical specifications of a 250 W AC PoE power module.

Table 3-20 Technical specifications of a 250 W AC PoE power module

Description	Item
Dimensions (W x D x H)	100 mm x 205 mm x 40 mm
Weight	0.8 kg
Rated input voltage range	100 V AC to 240 V AC; 50/60 Hz
Maximum input voltage range	90 V AC to 264 V AC; 47 Hz to 63 Hz
Maximum input current	4 A to 2 A
Maximum output current	<ul style="list-style-type: none"> ● +12 V: 10 A ● -53.5 V: 2.5 A
Maximum output power	<ul style="list-style-type: none"> ● PoE: 130 W ● Total: 250 W

3.6 500 W AC PoE Power Module

Version Mapping

Table 3-21 lists the switch chassis and software versions matching a 500 W AC PoE power module.

Table 3-21 Switch chassis and software versions matching a 500 W AC PoE power module

Power Module Name	S5700-SI S5700-EI	S5700-LI S5700S-LI S5700-HI S5710-EI
500 W AC PoE power module	Supported only by the S5700-28C-PWR-EI, S5700-52C-PWR-EI, S5700-28C-PWR-SI, S5700-52C-PWR-SI, S5700-24TP-PWR-SI, and S5700-48TP-PWR-SI NOTE This module is supported in V100R005C01 and later versions.	Not supported

Appearance

Figure 3-11 shows the appearance of a 500 W AC PoE power module.

Figure 3-11 Appearance of the 500 W AC PoE power module



Function

Table 3-22 describes the functions of a 500 W AC PoE power module.

Table 3-22 Functions of a 500 W AC PoE power module

Function	Description
PoE power supply	Complying with IEEE 802.3af and IEEE 802.3at, the PoE-enabled power module is able to remotely provide power for the switches of different vendors. IEEE 802.3af supports a maximum of 15.4 W power and IEEE 802.3at supports a maximum of 30 W power.
Input protection	Input overcurrent and undervoltage protection is provided.
Output protection	Output undervoltage, overvoltage, overcurrent, and short-circuit protection is provided.
EMC filter	-
Overtemperature protection	-
Surge protection	-

Panel Description

Figure 3-12 shows the panel of a 500 W AC PoE power module.

Figure 3-12 Panel of a 500 W AC PoE power module

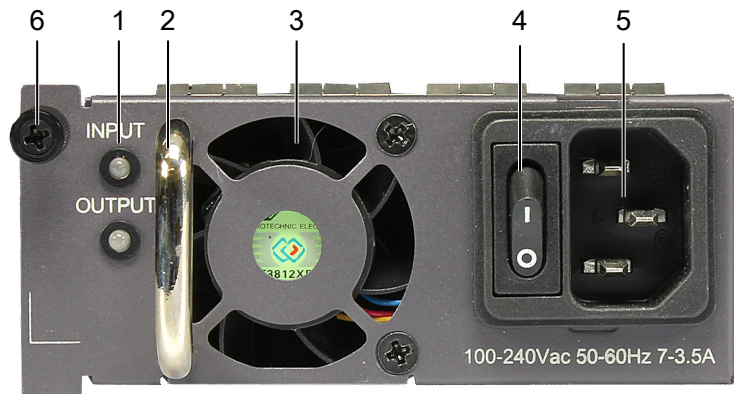

1. Power status indicator	2. Handle	3. Fan	4. Switch
5. AC power socket	6. Captive screw	-	-

Table 3-23 describes the indicators on a 500 W AC PoE power module panel.

Table 3-23 Description of indicators on a 500 W AC PoE power module panel

Indicator	Color	Description
INPUT	Off	The power cable is loose or no input AC power is provided.
	Green	Steady on: The AC input power is in the normal range.
	Red	Steady on: The AC input power is out of range, for example, undervoltage or overvoltage.
OUTPUT	Off	The power cable is loose or no input AC power is provided.
	Green	Steady on: The AC output power is in the normal range.
	Red	Steady on: The power output is out of range. <ul style="list-style-type: none"> ● Abnormal power fan operation ● Output overvoltage ● Output overcurrent ● Short circuit ● Overtemperature protection

Specifications

Table 3-24 describes the technical specifications of a 500 W AC PoE power module.

Table 3-24 Technical specifications of a 500 W AC PoE power module

Description	Item
Dimensions (W x D x H)	100 mm x 205 mm x 40 mm
Weight	1.06 kg
Rated input voltage range	100 V AC to 240 V AC; 50/60 Hz
Maximum input voltage range	90 V AC to 264 V AC; 47 Hz to 63 Hz
Maximum input current	7 A to 3.5 A
Maximum output current	<ul style="list-style-type: none">● +12 V: 10 A● -53.5 V: 7.11 A
Maximum output power	<ul style="list-style-type: none">● PoE: 380 W● Total: 500 W

3.7 580 W AC PoE Power Module

Version Mapping

Table 3-25 lists the switch chassis and software versions matching a 580 W AC PoE power module.

Table 3-25 Switch chassis and software versions matching a 580 W AC PoE power module

Power Module Name	S5710-EI	S5700-LI S5700S-LI S5700-SI S5700-EI S5700-HI
580 W AC PoE power module	Supported only by the S5710-52C-PWR-EI, S5710-28C-PWR-EI-AC, and S5710-52C-PWR-EI-AC NOTE This module is supported in V200R002C00 and later versions.	Not supported

Appearance

Figure 3-13 shows the appearance of a 580 W AC PoE power module.

Figure 3-13 Appearance of the 580 W AC PoE power module



Function

Table 3-26 describes the functions of a 580 W AC PoE power module.

Table 3-26 Functions of a 580 W AC PoE power module

Function	Description
PoE power supply	Complying with IEEE 802.3af and IEEE 802.3at, the PoE-enabled power module is able to remotely provide power for the switches of different vendors. IEEE 802.3af supports a maximum of 15.4 W power and IEEE 802.3at supports a maximum of 30 W power.
Input protection	Input overcurrent and undervoltage protection is provided.
Output protection	Output overvoltage, overcurrent, and short-circuit protection is provided.
Overtemperature protection	When the temperature of the power module exceeds a specified threshold, the power module stops supplying power. When the temperature falls into the normal range, the power module automatically resumes power supply.

Panel Description

Figure 3-14 shows the panel of a 580 W AC PoE power module.

Figure 3-14 Panel of a 580 W AC PoE power module

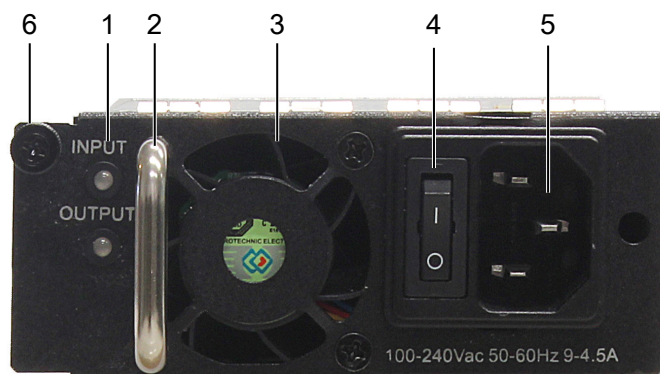

1. Power status indicator	2. Handle	3. Fan	4. Switch
5. AC power socket	6. Captive screw	-	-

Table 3-27 describes the indicators on a 580 W AC PoE power module panel.

Table 3-27 Description of indicators on a 580 W AC PoE power module panel

Indicator	Color	Description
INPUT	Off	The power cable is loose or no input AC power is provided.
	Green	Steady on: The AC input power is in the normal range.
	Red	Steady on: The AC input power is out of range, for example, undervoltage or overvoltage.
OUTPUT	Off	The power cable is loose or no input AC power is provided.
	Green	Steady on: The AC output power is in the normal range.
	Red	Steady on: The power output is out of range. <ul style="list-style-type: none"> ● Abnormal power fan operation ● Output overvoltage ● Output overcurrent ● Short circuit ● Overtemperature protection

Specifications

Table 3-28 describes the technical specifications of a 580 W AC PoE power module.

Table 3-28 Technical specifications of a 580 W AC PoE power module

Description	Item
Dimensions (W x D x H)	100 mm x 205 mm x 40 mm
Weight	<1.6 kg
Rated input voltage range	100 V AC to 240 V AC; 50/60 Hz
Maximum input voltage range	90 V AC to 290 V AC; 47 Hz to 63 Hz
Maximum input current	9 A to 4.5 A
Maximum output current	<ul style="list-style-type: none"> ● +12 V: 16.66 A ● -53.5 V: 7.11 A
Maximum output power	<ul style="list-style-type: none"> ● PoE: 380 W ● Total: 580 W

3.8 1150 W AC PoE Power Module

Version Mapping

Table 3-29 lists the mapping between device models and 1150 W AC PoE power modules.

Table 3-29 Mapping between device models and 1150 W AC PoE power modules

Power Module Name	S5710-EI	S5700-LI S5700S-LI S5700-SI S5700-EI S5700-HI
1150 W AC PoE power module	Supported only on the S5710-52C-PWR-EI NOTE The 1150 W AC PoE power module is supported in V200R002C00 and later versions.	Not supported

Appearance

Figure 3-15 shows the appearance of a 1150 W AC PoE power module.

Figure 3-15 Appearance of a 1150 W AC PoE power module



NOTE

After a 1150 W AC PoE power module is installed on a switch, it extrudes out from the chassis (black part on the module), as shown in **Figure 3-16**.

Figure 3-16 1150 W AC PoE power module on a switch



Functions

Table 3-30 describes the functions of a 1150 W AC PoE power module.

Table 3-30 Functions of a 1150 W AC PoE power module

Function	Description
PoE power supply	Complies with IEEE 802.3af and 802.3at, and remotely supplies power to devices from different vendors. IEEE 802.3af supports a maximum of 15.4 W power and IEEE 802.3at supports a maximum of 30 W power.
Input protection	Provides protection against input overcurrent and input undervoltage.
Output protection	Provides protection against output overvoltage, output overcurrent, and output short-circuit.
Overtemperature protection	When the temperature of the power module exceeds a specified threshold, the power module stops supplying power. When the temperature falls into the normal range, the power module automatically resumes power supply.

Panel

Figure 3-17 shows the panel of a 1150 W AC PoE power module.

Figure 3-17 Panel of a 1150 W AC PoE power module

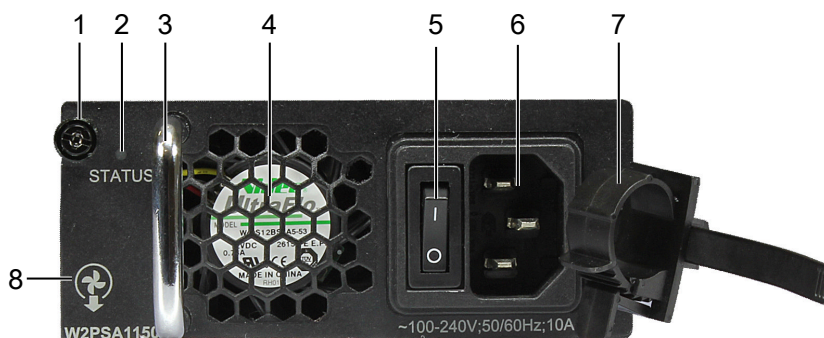

1. Captive screw	2. Indicator	3. Handle	4. Fan
5. Power switch	6. AC jack	7. Preventing trip for AC terminal	8: Airflow flag (absorbing air)

Table 3-31 describes indicators on the panel of a 1150 W AC PoE power module.

Table 3-31 Description of indicators on the panel of a 1150 W AC PoE power module

Indicator	Color	Meaning
STATUS	Off	<ul style="list-style-type: none"> ● The AC power input is abnormal, for example, no AC input power, AC input overvoltage, or AC input undervoltage occurs. ● The AC power output is abnormal, for example, output undervoltage or overtemperature occurs.
	Green	<ul style="list-style-type: none"> ● Steady on: The AC power input is in the normal range. ● Blinking: The AC power output is abnormal, for example, overvoltage, overcurrent, or short circuit occurs.

Specifications

Table 3-32 lists the specifications of a 1150 W AC PoE power module.

Table 3-32 Technical specifications of a 1150 W AC PoE power module

Item	Specification
Dimensions (W x D x H)	100 mm x 281 mm x 41.4 mm
Weight	< 3 kg
Rated input voltage	100 V AC to 240 V AC; 50/60 Hz NOTE A 1150 W AC PoE power module does not support 110 V input on an S5710-52C-PWR-EI switch. When 110 V input is used, 580 W AC power modules are recommended.
Maximum input voltage	90 V AC to 290 V AC; 45 Hz to 65 Hz
Maximum input current	10 A
Maximum output current	<ul style="list-style-type: none"> ● +12 V: 29.17 A ● -53.5 V: 14.95 A

Item	Specification
Maximum output power	<ul style="list-style-type: none"> ● PoE: 800 W (220 V)/450 W (110 V) ● Total: 1150 W (220 V)/800 W (110 V)

3.9 RPS1800 Power Supply

Version Mapping

Table 3-33 lists the switch chassis and software versions matching an RPS1800 power supply.

Table 3-33 Switch chassis and software versions matching an RPS1800 power supply

Power Module Name	S5700-LI S5700S-LI	S5700-SI	S5700-EI S5700-HI S5710-EI
RPS1800 power supply	<p>Supported</p> <p>NOTE This module is supported in V200R001C00 and later versions.</p> <p>The S5700-10P-PWR-LI-AC and S5700-10P-LI-AC do not support the RPS.</p>	<p>Supported only by the S5700-26X-SI-12S-AC</p> <p>NOTE This module is supported in V200R002C00 and later versions.</p>	Not supported

Appearance

Figure 3-18 shows the appearance of an RPS1800 power supply.

Figure 3-18 Appearance of an RPS1800 power supply



Function

The RPS1800 is a redundant power supply that ensures seamless failover when the internal power module of a switch fails. The RPS1800 can detect the failure of the internal power module on a connected switch and immediately supplies power to this switch. The switch can continue operating without a restart.

The RPS1800 provides the following power supply modes:

- Forcible PoE power supply:
 - The RPS1800 provides PoE power for a PoE switch when it has an R4815G1 DC power module installed.
 - One R4815G1 DC power module can provide power for only one PoE switch. An RPS1800 can provide 800 W PoE power with an output voltage of -53.5 V for two PoE switches when it has two R4815G1 DC power modules installed.
 - The forcible PoE power supply mode is used by default for PoE switches connected to an RPS1800. If S5700-28X-PWR-LI-AC, S5700-28TP-PWR-LI-AC, S5701-28TP-PWR-LI-AC, and S5700-52X-PWR-LI-AC switches need to use the 6:1 power backup mode, use a command on the switches to exit from the forcible PoE power supply mode. The S5700-28P-PWR-LI-AC and S5700-52P-PWR-LI-AC do not support the 6:1 power backup mode.
 - The RPS1800 provides backup for system power modules and PoE power modules of the connected PoE switches. However, it can provide power backup for only two PoE switches at the same time.
 - The six DC output ports have the same priority.

The S5700-28P-PWR-LI-AC, S5700-52P-PWR-LI-AC, S5700-28X-PWR-LI-AC, S5700-28TP-PWR-LI-AC, S5701-28TP-PWR-LI-AC, and S5700-52X-PWR-LI-AC support the forcible PoE power supply mode.

- 6:1 power backup:
 - The RPS1800 can connect to a maximum of six switches and ensures seamless failover for at most one switch when the internal power module of the switch fails.
 - When the internal power module of the switch powered by the RPS1800 recovers, the RPS1800 immediately restores to backup state.
 - Among the six DC output ports, port 1 has the highest priority. When the RPS1800 connects to six switches, the switch connected to port 1 can preferentially receive power from the RPS1800.
 - To use the 6:1 power backup mode for PoE switches, the PoE switches must exit from the forcible PoE power supply mode, and the RPS1800 must have R4815G1 DC power modules installed.
 - The RPS1800 only works as a backup for the system power module and PoE power module of the PoE switches, and does not provide PoE power for the switches.

The following switch models support the 6:1 power backup mode: S5700-28P-LI-AC, S5700-28P-LI-DC, S5700-52P-LI-AC, S5700-52P-LI-DC, S5700S-28P-LI-AC, S5700S-52P-LI-AC, S5700-28X-LI-AC, S5700-28X-LI-DC, S5700-52X-LI-AC, S5700-52X-LI-DC, S5700-26X-SI-12S-AC, S5700-28X-PWR-LI-AC, S5700-28TP-LI-AC, S5700-28TP-PWR-LI-AC, S5701-28TP-PWR-LI-AC, and S5700-52X-PWR-LI-AC.

 **NOTE**

The RPS1800 does not need R4815G1 DC power modules when providing power for non-PoE switches. R4815G1 DC power modules are hot swappable, while RPS cables are not.

Application

The RPS1800 can be deployed on various data or voice networks to avoid service interruption caused by failures of internal power modules of switches or external power supply systems, ensuring non-stop operation of data or voice networks. [Figure 3-19](#) and [Figure 3-20](#) show different deployments of the RPS1800.

Figure 3-19 Same external power supply system for RPS1800 and connected switches

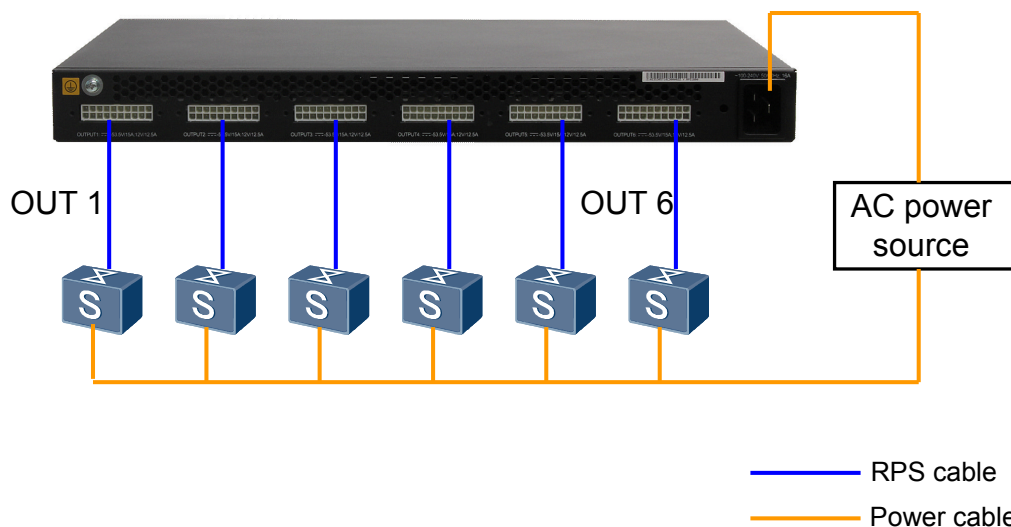
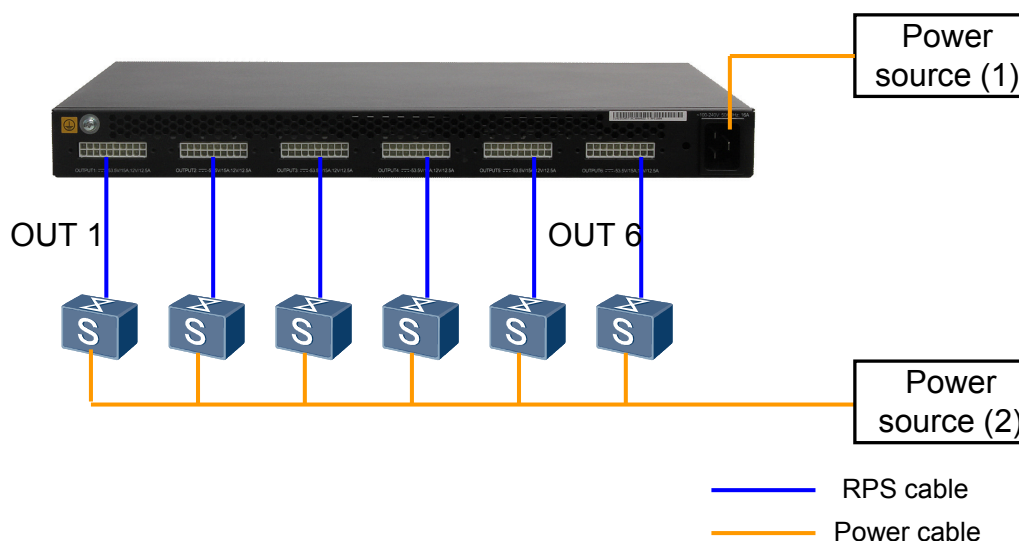

Figure 3-20 Different external power supply systems for RPS1800 and connected switches



When one of switches connected to the RPS1800 encounters an internal power module failure, the RPS1800 provides seamless failover for the switch. Then the RPS1800 does not provide power backup for the other switches connected until the internal power module of the faulty switch is recovered or replaced.

When more than one connected switch has an internal power module failure, the RPS1800 preferentially provides power for the switch connected to port 1. If the switch connected to port 1 has an internal power module failure when the RPS1800 is providing power for a switch connected to another port, the RPS1800 immediately stops power supply for this switch and starts to provide power to the switch connected to port 1.

If the RPS1800 has R4815G1 DC power modules installed, it can provide PoE power for PoE switches, as shown in [Figure 3-21](#).

Figure 3-21 PoE power supply for connected switches
With two R4815G1 DC power modules

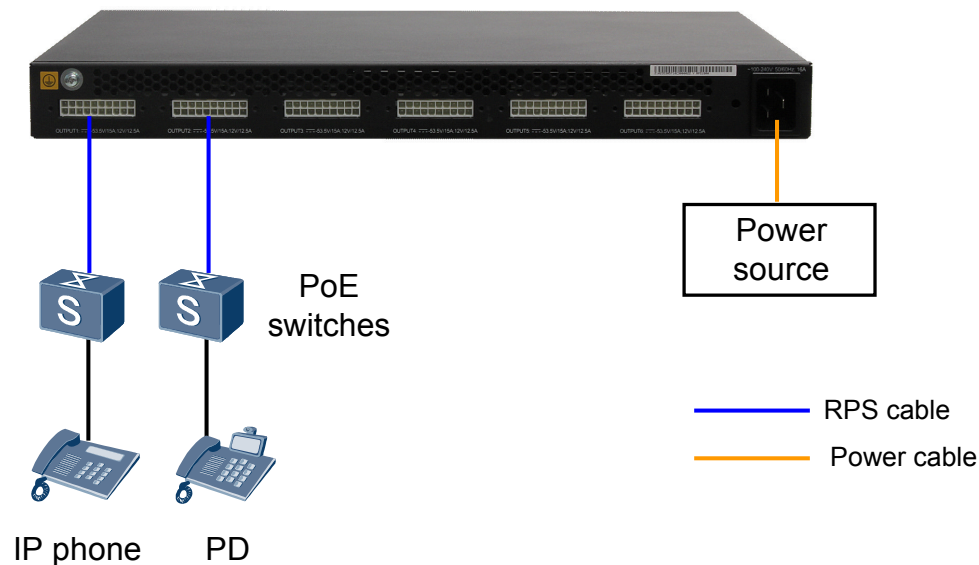

Panel Description

Figure 3-22 and **Figure 3-23** show the appearance of an RPS1800 power supply.

Figure 3-22 Front view of an RPS1800 power supply

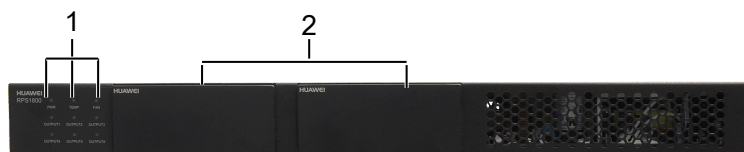
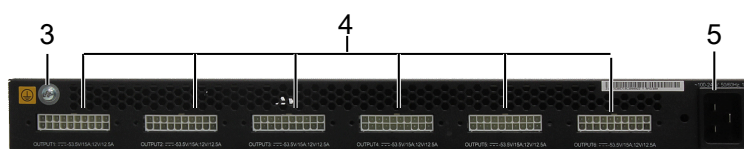

Figure 3-23 Rear view of an RPS1800 power supply



<p>1. RPS power indicators</p>	<p>2. Two swappable power module slots</p> <p>NOTE 870 W DC power modules can be installed in the slots.</p>	<p>3. Ground screw</p>	<p>4. Six DC output ports</p> <p>NOTE The DC output ports connect to switches through RPS cables.</p>	<p>5. AC power socket</p> <p>NOTE The AC power socket connects to an AC power source through an RPS1800 power cable.</p>
--------------------------------	---	------------------------	--	---

Table 3-34 describes the indicators on the panel of an RPS1800 power supply.

Table 3-34 Indicators on the panel of an RPS1800 power supply

Indicator	Color	Description
PWR	Green	Steady on: The power input is in normal range.
	Off	The switch is powered off.
TEMP	Green	Steady on: The temperature is in normal range.
	Red	Steady on: The temperature is out of range.
	Off	The switch is powered off.
FAN	Green	Steady on: The fan module runs properly.
	Red	Steady on: The fan module runs abnormally.
	Off	The switch is powered off.
OUTPUT	Green	Steady on: The RPS power supply is in cold backup state. Blinking: The RPS power supply is providing power.
	Orange	Steady on: The RPS power supply is unavailable and is providing power for other switches.
	Off	The switch is powered off.

Specifications

Table 3-35 describes the technical specifications of an RPS1800 power supply.

Table 3-35 Technical specifications of an RPS1800 power supply

Description	Parameter (without power modules installed)	Parameter (with one power module installed)	Parameter (with two power modules installed)
Dimensions (W x D x H)	442.0 mm x 310.0 mm x 43.6 mm		
Weight	4.0 kg	5.5 kg	7.0 kg
Operating temperature	0°C-50°C (at 0-2000 m altitude)		
Storage temperature	-40°C to +70°C		
Relative humidity	5% RH to 95% RH, non-condensing		

Description	Parameter (without power modules installed)	Parameter (with one power module installed)	Parameter (with two power modules installed)
Rated input voltage	220/110 V AC; 50/60 Hz		
Input voltage range	200 V AC to 240 V AC (220 V rated voltage input)/100 V AC to 120 V AC (110 V rated voltage input); 47 Hz to 63 Hz		
Rated input current	3 A	7.5 A	12 A
Maximum output current	12 V: 11.5 A	<ul style="list-style-type: none"> ● 12 V: 11.5 A ● -53.5 V: 15 A (Input voltage range: 200 V AC to 240 V AC) ● -53.5 V: 7.5 A (Input voltage range: 100 V AC to 120 V AC) 	<ul style="list-style-type: none"> ● 12 V: 11.5 A ● -53.5 V: 30 A (Input voltage range: 200 V AC to 240 V AC) ● -53.5 V: 15 A (Input voltage range: 100 V AC to 120 V AC)
Maximum output power	12 V: 140 W	<ul style="list-style-type: none"> ● 12 V: 140 W ● -53.5 V: 800 W (Input voltage range: 200 V AC to 240 V AC) ● -53.5 V: 400 W (Input voltage range: 100 V AC to 120 V AC) 	<ul style="list-style-type: none"> ● 12 V: 140 W ● -53.5 V: 1600 W (Input voltage range: 200 V AC to 240 V AC) ● -53.5 V: 800 W (Input voltage range: 100 V AC to 120 V AC)

 **NOTE**

On the RPS power supply, each interface provides 140 W power when the voltage is 12 V and 800 W power when the voltage is -53.5 V.

3.10 870 W DC Power Module

Version Mapping

[Table 3-36](#) lists the switch chassis and software versions matching an 870 W DC power module.

Table 3-36 Switch chassis and software versions matching an 870 W DC power module

Power Module Name	RPS1800
R4815G1 870 W DC power module	Supported NOTE This module is supported in V200R001C00 and later versions.

Appearance

Figure 3-24 shows the appearance of an 870 W DC power module.

Figure 3-24 Appearance of an 870 W DC power module

Function

An 870 W DC power module can be configured on the RPS1800A to provide 100 V AC to 240 V AC power input and -53.5 V DC default power input, a maximum of 800 W power, and functions described in **Table 3-37**.

Table 3-37 Functions of an 870 W DC power module

Function	Description
Input protection	Input undervoltage and overvoltage protection is provided.
Output protection	Output overvoltage, overcurrent, and short-circuit protection is provided.
Overtemperature protection	-
Soft start, complete protection, low noise, and parallel connections	-

Function	Description
Power module monitoring	Latest power supply monitoring technology that can implement real-time monitoring on the status and load of the power module
Output voltage adjustment in the background	-
Voltage and current adjustments, current balance, and hot swap	-

Panel Description

Figure 3-25 shows the panel of an 870 W DC power module.

Figure 3-25 Panel of an 870 W DC power module

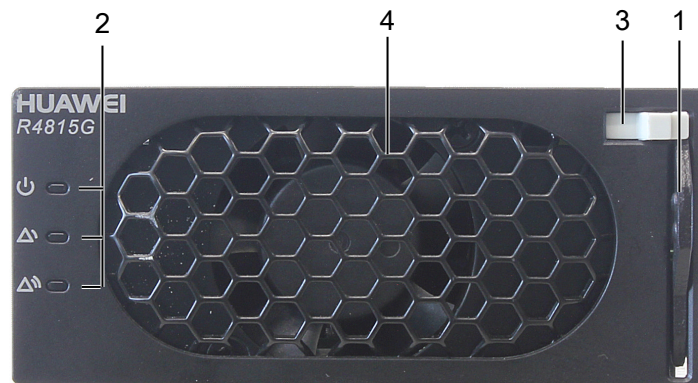



1. Extensible handle	2. Power status indicator	3. Slide pinch	4. Fan
----------------------	---------------------------	----------------	--------

Table 3-38 describes the indicators on an 870 W DC power module panel.

Table 3-38 Description of indicators on an 870 W DC power module panel

Indicator	Color	Description
Power indicator 	Off	No AC input power is provided or the power module is faulty.
	Green	Steady on: AC input power is provided. Blinking at a frequency of 0.5 Hz: The power module is in manual query state. Blinking at a frequency of 4 Hz: Applications are being loaded on the power module.
Alarm indicator	Off	No alarm is triggered on the power module.

Indicator	Color	Description
	Yellow	Steady on: <ul style="list-style-type: none"> ● The power alarm is generated due to ambient overtemperature. ● The power-off alarm is triggered by high or low ambient temperature. ● Input undervoltage and overvoltage occur. ● The power module is in dormant state. Blinking at a frequency of 0.5 Hz: The power module disconnects from the RPS1800.
Fault indicator 	Off	No fault occurs on the power module.
	Red	Steady on: The power output is locked because of output overvoltage or no power output is provided because the power module is faulty.

Specifications

[Table 3-39](#) describes the technical specifications of an 870 W DC power module.

Table 3-39 Technical specifications of an 870 W DC power module

Description	Item
Dimensions (W x D x H)	95.5 mm x 208 mm x 40.8 mm
Weight	<1.5 kg
Rated input voltage	220/110 V AC; 50/60 Hz
Maximum input voltage range	200 V AC to 240 V AC (220 V rated voltage input)/100 V AC to 120 V AC (110 V rated voltage input); 47 Hz to 63 Hz
Maximum input current	≤4.7 A
Maximum output power	<ul style="list-style-type: none"> ● 870 W (Voltage range: 200 V to 240 V) ● 435 W (Voltage range: 100 V to 120 V)

4 Fan Module

About This Chapter

[4.1 CX7E1FANA Fan Module](#)

4.1 CX7E1FANA Fan Module

Version Mapping

Table 4-1 lists the switch chassis and software versions matching a CX7E1FANA fan module.

Table 4-1 Switch chassis and software versions matching a CX7E1FANA fan module

Fan Module Name	S5700-EI	S5700-SI	S5700-LI S5700S-LI S5700-HI S5710-EI
CX7E1FANA fan module	Supported NOTE This module is supported in V100R005C01 and later versions.	Only the S5700-28C-SI, S5700-52C-SI, S5700-28C-PWR-SI, S5700-52C-PWR-SI, S5700-24TP-PWR-SI, and S5700-48TP-PWR-SI supported NOTE This module is supported in V100R005C01 and later versions.	Not supported

Appearance

Figure 4-1 shows the appearance of a CX7E1FANA fan module.

Figure 4-1 Appearance of a CX7E1FANA fan module



Function

The CX7E1FANA fan module consists of two fans, which is used to absorb cold air into the switch chassis to dissipate heat. The CX7E1FANA fan module can be replaced when the switch is running.

Panel Description

Figure 4-2 shows the panel of a CX7E1FANA fan module.

Figure 4-2 Panel of a CX7E1FANA fan module

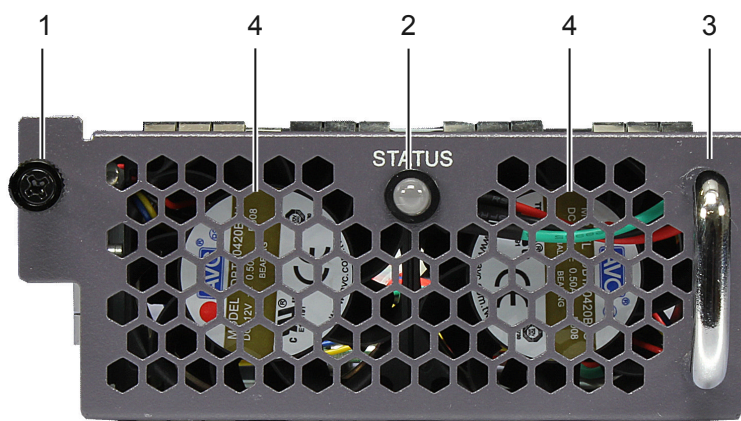

1. Captive screw	2. Fan module indicator	3. Handle	4. Two fans
------------------	-------------------------	-----------	-------------

Table 4-2 shows indicators on the CX7E1FANA fan module panel.

Table 4-2 Description of indicators on the CX7E1FANA fan module panel

Indicator	Color	Description
STATUS	Off	The fan module is not running.
	Green	<ul style="list-style-type: none"> ● Blinking slowly: The fan module is working properly and its communication is normal. ● Blinking fast: The fan module is working properly but its communication is abnormal.
	Red	<ul style="list-style-type: none"> ● Steady on: The fan module has a hardware fault and must be replaced. ● Blinking slowly: An alarm has been generated, and you need to handle it accordingly. Common causes of this alarms include errors of dual in-line package (DIP) switches, short-circuit, fan blades blocked, and fault of the fan module.

Specifications

Table 4-3 describes the technical specifications of a CX7E1FANA fan module.

Table 4-3 Technical specifications of a CX7E1FANA fan module

Description	Item
Dimensions (W x D x H)	103 mm x 99.2 mm x 39.6 mm
Weight	250±20 g
Maximum power consumption	12 W
Maximum wind pressure	375 Pa
Maximum wind rate	40 CFM
Operating voltage range	12 V DC

5 Cards

About This Chapter

[5.1 Introduction](#)

[5.2 ES5D000X2S00/ES5D000X4S01 \(2/4-Port 10GE SFP+ Front Optical Interface Card\)](#)

[5.3 ES5D000G4S01/ES5D00G4SA01 \(4-Port GE SFP Front Optical Interface Card\)](#)

[5.4 ES5D00X2SA00/ES5D00X4SA00 \(2/4-Port GE SFP/10GE SFP+ Front Optical Interface Card\)](#)

[5.5 ES5D00G4SC00 \(4-Port GE SFP Front Optical Interface Card\)](#)

[5.6 ES5D21G08S00 \(8-Port GE SFP Rear Optical Interface Card\)](#)

[5.7 ES5D21G08T00 \(8-Port GE Rear Electrical Interface Card\)](#)

[5.8 ES5D21X02S00 \(2-Port GE SFP/10GE SFP+ Rear Optical Interface Card\)](#)

[5.9 ES5D00ETPC00 \(Stack Rear Card\)](#)

[5.10 ES5D00ETPB00 \(Extended Rear Card\)](#)

5.1 Introduction

5.1.1 Card Classification

Table 5-1 lists the cards supported by the S5700.

Table 5-1 Cards supported by the S5700

Card Type	Card Name	Card Description	Weight	Maximum Power Consumption
Front card	ES5D000X2S00	2-port 10GE SFP+ front optical interface card	0.2 kg	6.5 W
	ES5D000X4S01	4-port 10GE SFP+ front optical interface card	0.3 kg	13 W
	ES5D000G4S01	4-port GE front optical interface card	0.2 kg	6 W
	ES5D00G4SA01	4-port GE front optical interface card	0.2 kg	4.5 W
	ES5D00X2SA00	2-port GE SFP/10GE SFP+ front optical interface card	0.5 kg	7 W
	ES5D00X4SA00	4-port GE SFP/10GE SFP+ front optical interface card	0.5 kg	10 W
	ES5D00G4SC00	4-port GE SFP front optical interface card	0.3 kg	4 W
Rear card	ES5D21G08S00	8-port GE SFP rear optical interface card	0.3 kg	10.9 W
	ES5D21G08T00	8-port GE rear electrical interface card	0.3 kg	10.9 W

Card Type	Card Name	Card Description	Weight	Maximum Power Consumption
	ES5D21X02S00	2-port GE SFP/10GE SFP+ rear optical interface card	0.5 kg	7 W
	ES5D00ETPC00	Stack rear card	0.2 kg	0.5 W
	ES5D00ETPB00	Extended channel rear card	0.2 kg	0.1 W



NOTE

Some cards are sold with other cards, for example, front card ES5D000X4S01 is sold with rear card ES5D000ETPB00. When a card is faulty, provide the bar code of the card for Huawei technical personnel to fix the problem.

5.1.2 Card Structure and Dimensions

Card Structure

Figure 5-1 shows appearance of a card.

Figure 5-1 Appearance of a card

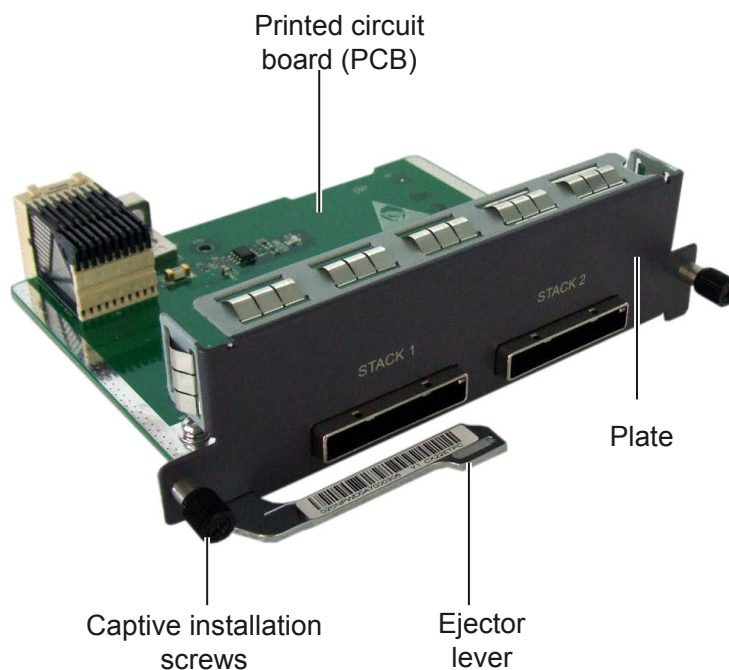

A card consists of the following components:

- Printed circuit board (PCB)

The PCB contains all the functional chips of the card and is the core of the card. The PCB provides indicators and ports on the front panel.

 **NOTE**

Different cards provide different indicators and ports. For details, see the description of specific cards.

- Front panel, consisting of the captive installation screws, ejector levers, and plate
 - Captive installation screws: fix the card into the chassis.
 - Ejector lever: allows you to insert and remove the card.
 - Plate: connects the ejector levers and the PCB.

Card Dimension

Figure 5-2 shows the definitions of width, height, and depth of a card.

Figure 5-2 Card dimensions

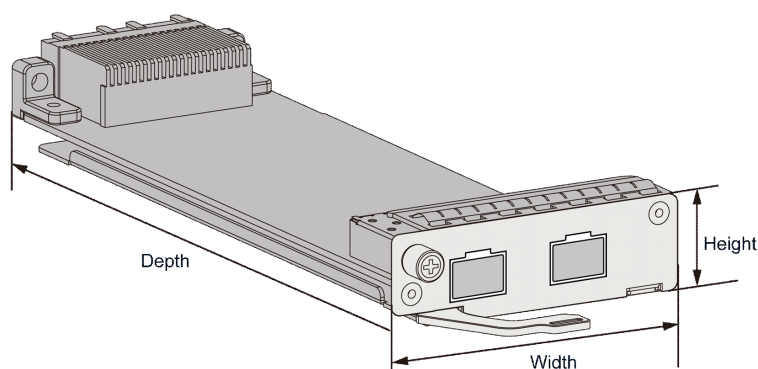

 **NOTE**

The card dimensions are defined as follows:

- Width: the longest distance between the tops of two ejector levers
- Depth: the distance between a plate and the end of PCB
- Height: the height of the front panel

5.1.3 Port Numbering

On the S5700, ports are numbered in the format of slot ID/card ID/port sequence number.

- Slot ID:

The slot ID identifies in which slot a card is installed. The S5700 supports only one card that integrates the control, switching, and service functions, so the slot ID is always 0.

- card ID:

The S5700 supports one front card or two rear cards, so the value is 0, 1, or 2. The value 1 or 2 indicates a port on a card. The value 0 indicates a port on the host.

- Port sequence number
The port sequence number indicates the number of each port on a card, as shown in [Table 5-2](#).

Table 5-2 Port numbering rules

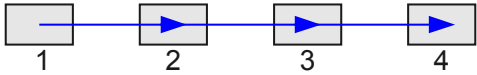
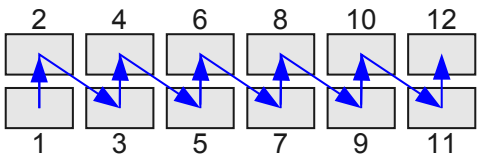
Number of Rows for Ports	Diagram for Port Numbering	Description
1		There is only one row of ports on the interface card. These ports are numbered from left to right starting with 1.
2		There are two rows of ports on the interface card. These ports are numbered from bottom to top and left to right starting with 1.

- If a port does not reside on a front card and is the fifth port from left to right and top to bottom, the interface is named Ethernet 0/0/5. If the stacking function is enabled and the stack ID is 1, the port is named Ethernet 1/0/5.
- If a port resides on a front card and is the third port from left to right, the port is named Ethernet 0/1/3. If the stacking function is enabled and the stack ID is 1, the port is named Ethernet 1/1/3.

5.2 ES5D000X2S00/ES5D000X4S01 (2/4-Port 10GE SFP+ Front Optical Interface Card)

5.2.1 Introduction

The ES5D000X2S00/ES5D000X4S01 provides two/four 10GE SFP+ optical ports to implement data access and line-speed switching. The ES5D000X2S00/ES5D000X4S01 can be inserted in to the front card slot of the S5700-28C-EI, S5700-52C-EI, S5700-28C-EI-24S, S5700-28C-SI, S5700-52C-SI, S5700-28C-PWR-SI, S5700-52C-PWR-SI, S5700-28C-PWR-EI, or S5700-52C-PWR-EI.

[Figure 5-3](#) and [Figure 5-4](#) show the appearance of the ES5D000X2S00/ES5D000X4S01.

Figure 5-3 Appearance of the ES5D000X2S00

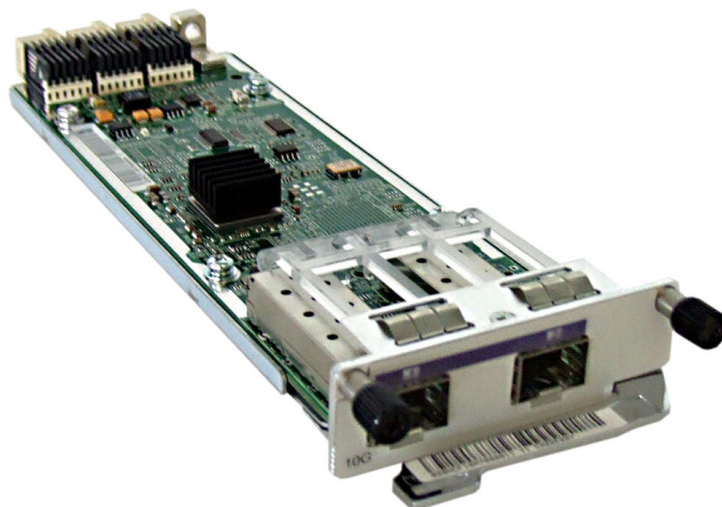
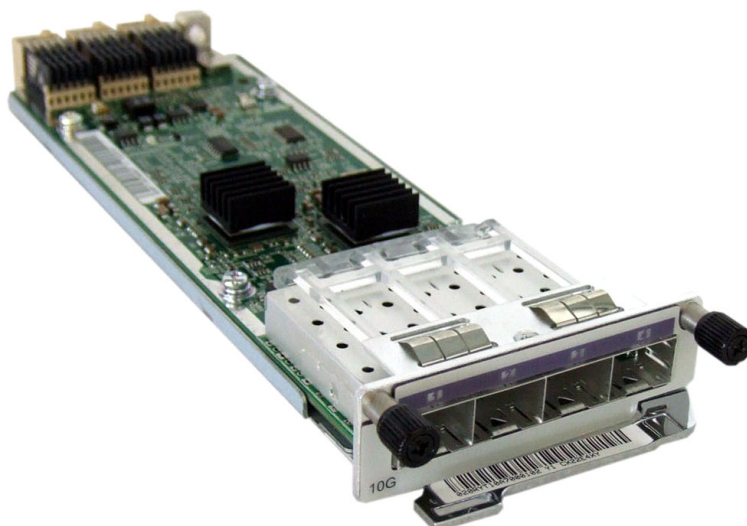

Figure 5-4 Appearance of the ES5D000X4S01



5.2.2 Version Mapping

Table 5-3 lists the switch chassis and software versions matching the ES5D000X2S00/ES5D000X4S01.

Table 5-3 Version mapping

Card Name	Card Description
ES5D000X2S00	Supported in V100R005C01 and later versions

Card Name	Card Description
ES5D000X4S01	Supported in V100R005C01 and later versions

5.2.3 Functions and Features

Table 5-4 describes the functions and features of the ES5D000X2S00/ES5D000X4S01.

Table 5-4 Functions and features of the ES5D000X2S00/ES5D000X4S01

Functions and Features	Description
Basic function	The ES5D000X2S00/ES5D000X4S01 provides two/four 10GE SFP+ optical ports to implement data access and line-speed switching.
10GE port	A 10GE port has a higher cost than other ports, so it is used as an uplink aggregation port on high-bandwidth and high-speed MANs or backbone networks. When an enterprise user needs the high-quality triple-play service, the ES5D000X2S00/ES5D000X4S01 provides access ports for downlink devices or networks. Different transmission distances can be supported by changing SFP+ optical modules.
Hot swap	Not supported

5.2.4 Usage Constraints



CAUTION

- An ES5D000X4S01 front card must be used with an ES5D00ETPB00 extended rear card; otherwise, exceptions may occur on the ES5D000X4S01 front card.
- An ES5D000X4S01 front card must be used with an ES5D00ETPB00 card whose PCB version is VC.
- The ES5D000X4S01 front subcard must be used with PCB of VB or later versions on S5700-EI switches (VC on S5700-52C-EI). Use the **display version** command to check the PCB version of a switch.

5.2.5 Indicators and Ports

Indicator Description

Figure 5-5 and **Figure 5-6** show indicators on the ES5D000X2S00/ES5D000X4S01.

Figure 5-5 Indicators on the ES5D000X2S00

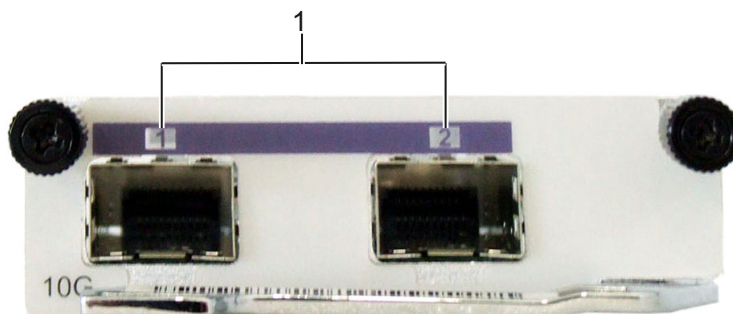

Figure 5-6 Indicators on the ES5D000X4S01

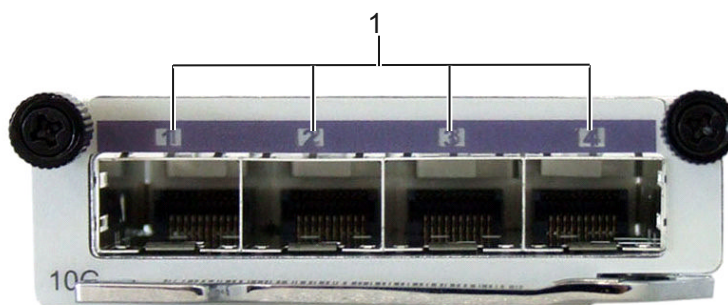

Table 5-5 shows indicators on the ES5D000X2S00/ES5D000X4S01.

Table 5-5 Description of indicators on the ES5D000X2S00/ES5D000X4S01

Number	Indicator	Color	Description
1	ACT/LINK	Green	<ul style="list-style-type: none"> ● Steady on: The link is connected. ● Blinking: The port is transmitting or receiving data.
		Off	The port is not connected.

Port Description

Figure 5-8 shows the ports on the ES5D000X2S00/ES5D000X4S01.

Figure 5-7 Ports on the ES5D000X2S00

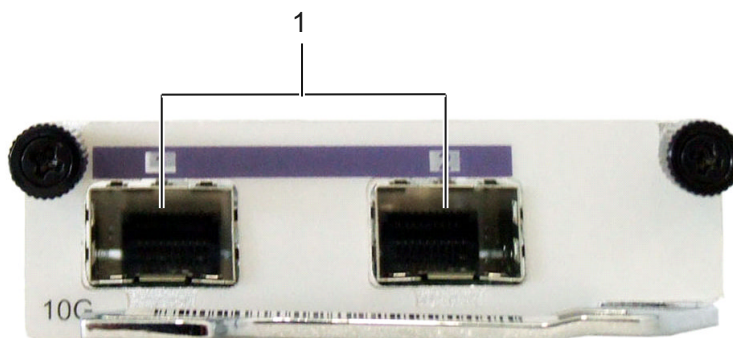
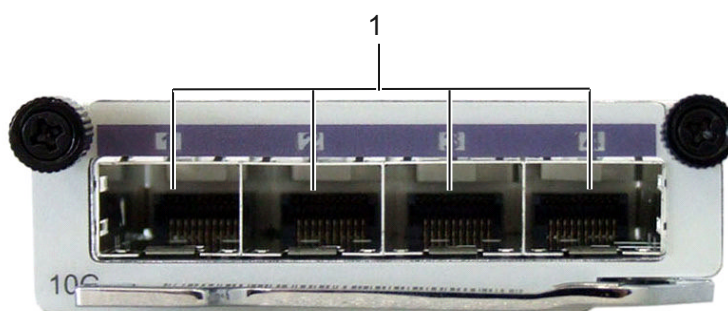

Figure 5-8 Ports on the ES5D000X4S01



1. Two/Four 10GE SFP+ optical ports

10GE SFP+ optical port

The ES5D000X2S00/ES5D000X4S01 provides two/four 10GE optical ports to transmit and receive Ethernet services at 1 Gbit/s or 10 Gbit/s. [Table 5-6](#) describes attributes of a 10GE SFP+ optical port.

 **NOTE**

Two/Four optical ports provided by the ES5D000X2S00/ES5D000X4S01 support the 10GE SFP+ optical module, GE optical module, GE copper module (used together with shielded network cables), and SFP+ cables on the S5700-SI, and supports only the 10GE SFP+ optical module and SFP+ cables on the S5700-EI.

Table 5-6 Attributes of a 10GE SFP+ optical port

Attribute	Description
Connector type	LC/PC
Optical port attribute	Depending on the optical module used on the port (see 7.2 SFP/eSFP Modules and 7.3 SFP+ Modules)

Attribute	Description
Standards compliance	IEEE 802.3ae
Frame format	Ethernet_II, Ethernet_SAP, Ethernet_SNAP
Network protocol	IP

5.2.6 Specifications

Table 5-7 describes the specifications of the ES5D000X2S00/ES5D000X4S01.

Table 5-7 Specifications of the ES5D000X2S00/ES5D000X4S01

Parameter	Description
Physical specifications	<ul style="list-style-type: none">● Dimensions (W x D x H): 70 mm x 197 mm x 22 mm● Weight<ul style="list-style-type: none">- ES5D000X2S00: 0.2 kg- ES5D000X4S01: 0.3 kg● Maximum power consumption<ul style="list-style-type: none">- ES5D000X2S00: 6.5 W- ES5D000X4S01: 13 W
Environment parameters	<ul style="list-style-type: none">● Operating temperature: 0°C to 50°C● Relative humidity: 10% RH to 90% RH● Storage temperature: -40°C to +70°C
EMC	<ul style="list-style-type: none">● CISPR22 Class A● CISPR24● EN55022 Class A● EN50024● ETSI EN 300 386 Class A● CFR 47 FCC Part 15 Class A● ICES 003 Class A● AS/NZS CISPR22 Class A● IEC61000-4-2● ITU-T K 20● ITU-T K 44
Environment standard	<ul style="list-style-type: none">● RoHS● REACH

Parameter	Description
Safety	<ul style="list-style-type: none">● IEC 60950-1● EN 60950-1/A11/A12● UL 60950-1● CSA C22.2 No 60950-1● AS/NZS 60950.1
Laser safety	<ul style="list-style-type: none">● IEC60825-1● IEC60825-2● EN60825-1● EN60825-2

5.2.7 Ordering Information

To order the card, contact the local Huawei sales representatives. To download software, visit the Huawei enterprise website: <http://enterprise.huawei.com>.

Table 5-8 lists the ES5D000X2S00/ES5D000X4S01 ordering information.

Table 5-8 ES5D000X2S00/ES5D000X4S01 ordering information

Card Description	Card Name
2-port 10GE SFP+ optical interface card	ES5D000X2S00
4-port 10GE SFP+ optical interface card (including ES5D000X4S01 4-port 10GE front card and ES5D00ETPB00 extended channel rear card)	ES5D000X4S00 NOTE The ES5D000X4S01 front card must work with the ES5D00ETPB00 rear card, so the two cards are sold together. ES5D000X4S00 is the collective model of the two cards.

5.3 ES5D000G4S01/ES5D00G4SA01 (4-Port GE SFP Front Optical Interface Card)

5.3.1 Introduction

The ES5D000G4S01/ES5D00G4SA01 provides four GE SFP optical ports to implement data access and line-speed switching.

The ES5D000G4S01 can be inserted into the front card slot of the S5700-28C-EI, S5700-52C-EI, S5700-28C-EI-24S, S5700-28C-PWR-EI, or S5700-52C-PWR-EI.

The ES5D00G4SA01 can be inserted into the front card slot of the S5700-28C-PWR-SI, S5700-52C-PWR-SI, S5700-28C-SI, or S5700-52C-SI.

Figure 5-9 and **Figure 5-10** show the appearance of the ES5D00G4S01/ES5D00G4SA01.

Figure 5-9 Appearance of the ES5D00G4S01

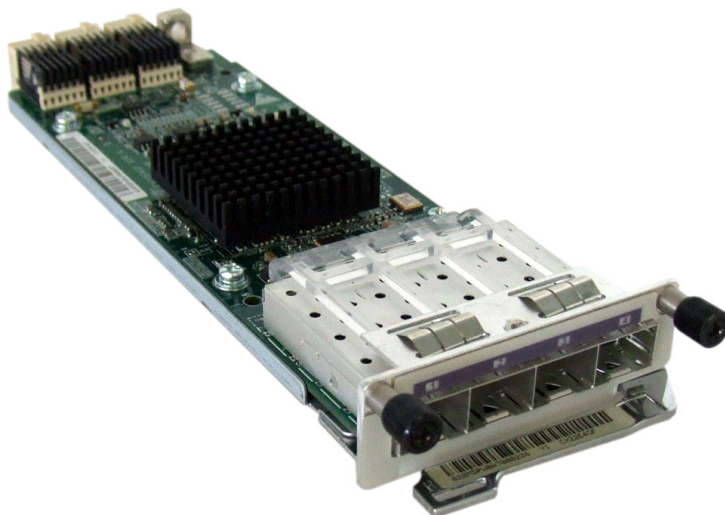
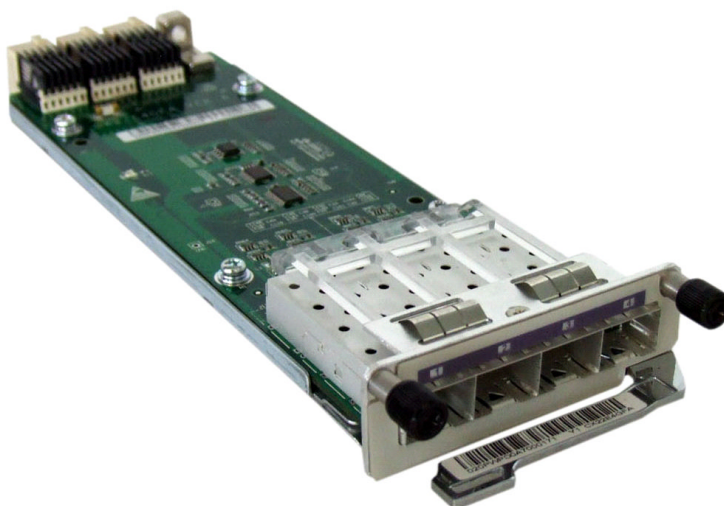

Figure 5-10 Appearance of the ES5D00G4SA01



5.3.2 Version Mapping

Table 5-9 lists the switch chassis and software versions matching the ES5D00G4S01/ES5D00G4SA01.

Table 5-9 Version mapping

Card Name	Card Description
ES5D000G4S01	Supported in V100R005C01 and later versions
ES5D00G4SA01	Supported in V100R005C01 and later versions

5.3.3 Functions and Features

Table 5-10 describes the functions and features of the ES5D000G4S01/ES5D00G4SA01.

Table 5-10 Functions and features of the ES5D000G4S01/ES5D00G4SA01

Functions and Features	Description
Basic function	The ES5D000G4S01/ES5D00G4SA01 provides four GE SFP optical ports to implement data access and line-speed switching.
GE port	A GE port has a higher cost than other ports, so it is used as an uplink aggregation port on high-bandwidth and high-speed MANs or backbone networks. When an enterprise user needs the high-quality triple-play service, the ES5D000G4S01/ES5D00G4SA01 provides access ports for downlink devices or networks. ES5D000G4S01/ES5D00G4SA01 uses optical fibers as transmission media. The transmission distance varies according to the optical module type.
Hot swap	Not supported

5.3.4 Usage Constraints



CAUTION

- If the ES5D000G4S01 is installed on the S5700-SI, or the ES5D00G4SA01 is installed on the S5700-EI, the front card cannot register.
- The ES5D000G4S01/ES5D00G4SA01 front card must be used with an ES5D00ETPB00 extended rear card; otherwise, only the first two ports of the front card can work.
- When the S5700-EI/S5700-SI is equipped with the ES5D00ETPC00 stack rear card: If the ES5D000G4S01/ES5D00G4SA01 front card is used, only ports 1 and 2 are available.

5.3.5 Indicators and Ports

Indicator Description

Figure 5-11 shows indicators on the ES5D000G4S01/ES5D00G4SA01.

Figure 5-11 Indicators on the ES5D000G4S01/ES5D00G4SA01

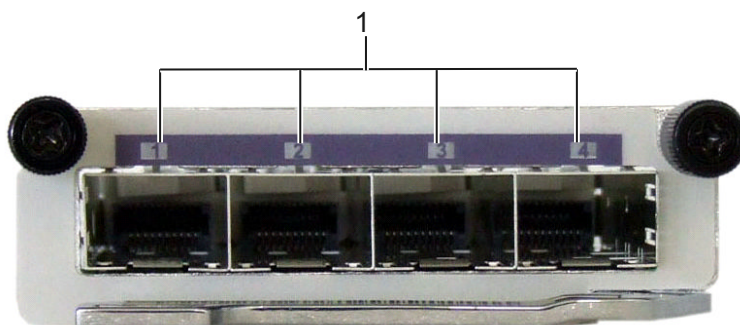

Table 5-11 shows indicators on the ES5D000G4S01/ES5D00G4SA01.

Table 5-11 Description of indicators on the ES5D000G4S01/ES5D00G4SA01

Number	Indicator	Color	Description
1	ACT/LINK	Green	<ul style="list-style-type: none"> ● Steady on: The link is connected. ● Blinking: The port is transmitting or receiving data.
		Off	The port is not connected.

Port Description

Figure 5-12 shows the ports on the ES5D000G4S01/ES5D00G4SA01.

Figure 5-12 Ports on the ES5D000G4S01/ES5D00G4SA01

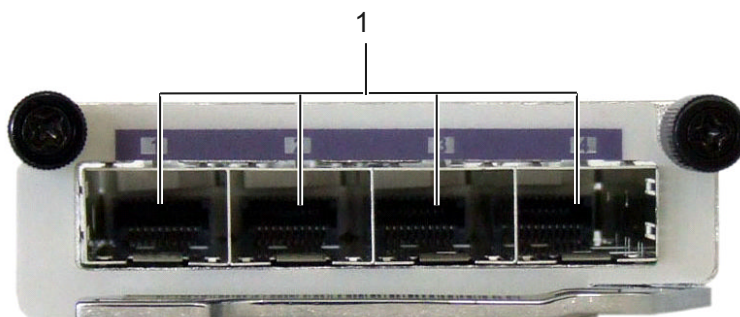

1. Four GE SFP optical ports

GE SFP optical port

The ES5D000G4S01/ES5D00G4SA01 provides four 1000M optical ports to transmit and receive Ethernet services at 1000 Mbit/s. [Table 5-12](#) describes attributes of an SFP optical port.

 **NOTE**

Four optical ports provided by the ES5D000G4S01/ES5D00G4SA01 support the GE optical module and GE copper module (used together with shielded network cables).

Table 5-12 Attributes of an SFP optical port

Attribute	Description
Connector type	LC/PC
Optical port attribute	Depending on the optical module used on the port (see 7.2 SFP/eSFP Modules)
Standards compliance	IEEE 802.3z
Frame format	Ethernet_II, Ethernet_SAP, Ethernet_SNAP
Network protocol	IP

5.3.6 Specifications

[Table 5-13](#) describes the specifications of the ES5D000G4S01/ES5D00G4SA01.

Table 5-13 Specifications of the ES5D000G4S01/ES5D00G4SA01

Parameter	Description
Physical specifications	<ul style="list-style-type: none">● Dimensions (W x D x H): 70 mm x 197 mm x 22 mm● Weight: 0.2 kg● Maximum power consumption<ul style="list-style-type: none">- ES5D000G4S01: 6 W- ES5D00G4SA01: 4.5 W
Environment parameters	<ul style="list-style-type: none">● Operating temperature: 0°C to 50°C● Relative humidity: 10% RH to 90% RH● Storage temperature: -40°C to +70°C

Parameter	Description
EMC	<ul style="list-style-type: none"> ● CISPR22 Class A ● CISPR24 ● EN55022 Class A ● EN50024 ● ETSI EN 300 386 Class A ● CFR 47 FCC Part 15 Class A ● ICES 003 Class A ● AS/NZS CISPR22 Class A ● IEC61000-4-2 ● ITU-T K 20 ● ITU-T K 44
Environment standard	<ul style="list-style-type: none"> ● RoHS ● REACH
Safety	<ul style="list-style-type: none"> ● IEC 60950-1 ● EN 60950-1/A11/A12 ● UL 60950-1 ● CSA C22.2 No 60950-1 ● AS/NZS 60950.1
Laser safety	<ul style="list-style-type: none"> ● IEC60825-1 ● IEC60825-2 ● EN60825-1 ● EN60825-2

5.3.7 Order Information

To order the card, contact the local Huawei sales representatives. To download software, visit the Huawei enterprise website: <http://enterprise.huawei.com>.

Table 5-14 lists the ES5D000G4S01/ES5D00G4SA01 order information.

Table 5-14 ES5D000G4S01/ES5D00G4SA01 order information

Card Description	Card Name
4-port GE SFP optical interface card (applicable to the EI series, including ES5D000G4S01 4-port GE front card and ES5D00ETPB00 extended channel rear card)	ES5D000G4S00 NOTE The ES5D000G4S01 front card must work with the ES5D00ETPB00 rear card, so the two cards are sold together. ES5D000G4S00 is the collective model of the two cards.

Card Description	Card Name
4-port GE SFP optical interface card (applicable to the SI series, including ES5D00G4SA01 4-port GE front card and ES5D00ETPB00 extended channel rear card)	ES5D00G4SA00 NOTE The ES5D00G4SA01 front card must work with the ES5D00ETPB00 rear card, so the two cards are sold together. ES5D00G4SA00 is the collective model of the two cards.

5.4 ES5D00X2SA00/ES5D00X4SA00 (2/4-Port GE SFP/10GE SFP+ Front Optical Interface Card)

5.4.1 Introduction

The ES5D00X2SA00/ES5D00X4SA00 provides two/four 10GE SFP+ optical ports to implement data access and line-speed switching.

The ES5D00X2SA00/ES5D00X4SA00 can be inserted into the front card slot of the S5700-28C-HI or S5700-28C-HI-24S.

Figure 5-13 and **Figure 5-14** show the appearance of the ES5D00X2SA00/ES5D00X4SA00.

Figure 5-13 Appearance of the ES5D00X2SA00

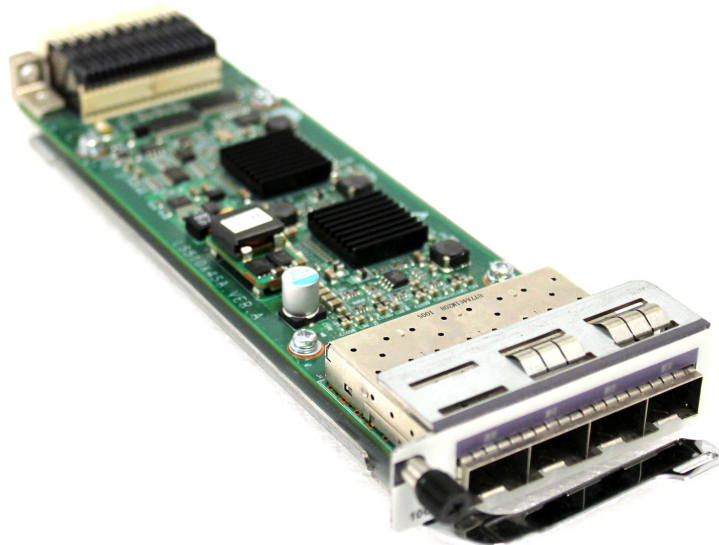

Figure 5-14 Appearance of the ES5D00X4SA00

5.4.2 Version Mapping

Table 5-15 lists the switch chassis and software versions matching the ES5D00X2SA00/ES5D00X4SA00.

Table 5-15 Version mapping

Card Name	Card Description
ES5D00X2SA00	Supported in V100R006C01 and later versions
ES5D00X4SA00	Supported in V100R006C01 and later versions

5.4.3 Functions and Features

Table 5-16 describes the functions and features of the ES5D00X2SA00/ES5D00X4SA00.

Table 5-16 Functions and features of the ES5D00X2SA00/ES5D00X4SA00

Functions and Features	Description
Basic function	The ES5D00X2SA00/ES5D00X4SA00 provides two/four 10GE SFP+ optical ports to implement data access and line-speed switching.

Functions and Features	Description
Enhanced service	The S5700-HI powers on or off the ES5D00X2SA00/ES5D00X4SA00, detects whether the ES5D00X2SA00/ES5D00X4SA00 is installed or not, and manages PHY chips and optical ports on the ES5D00X2SA00/ES5D00X4SA00. The ES5D00X2SA00/ES5D00X4SA00 works with the entire system to provide enhanced service features such as OAM and BFD.
Hot swap	Supported

5.4.4 Indicators and Ports

Indicator Description

[Figure 5-15](#) and [Figure 5-16](#) show indicators on the ES5D00X2SA00/ES5D00X4SA00.

Figure 5-15 Indicators on the ES5D00X2SA00

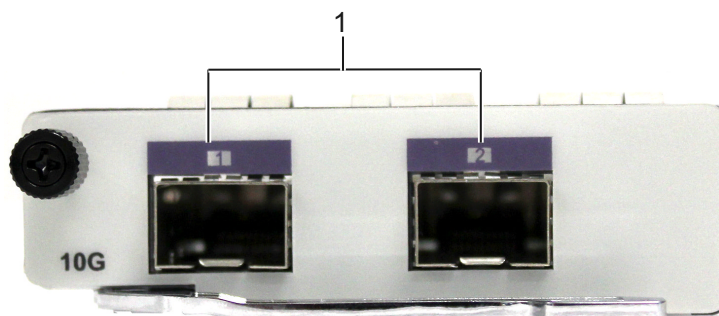

Figure 5-16 Indicators on the ES5D00X4SA00

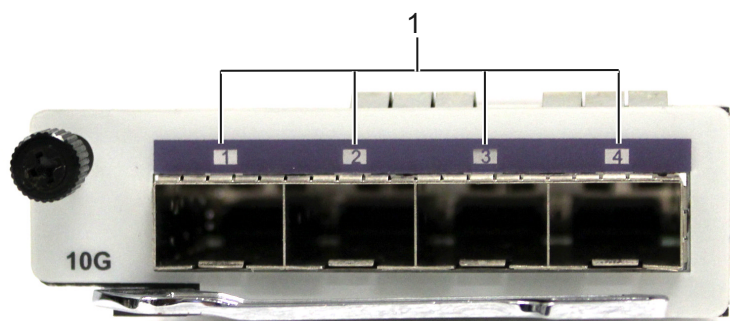

Table 5-17 shows indicators on the ES5D00X2SA00/ES5D00X4SA00.

Table 5-17 Description of indicators on the ES5D00X2SA00/ES5D00X4SA00

Number	Indicator	Color	Description
1	ACT/LINK	Green	<ul style="list-style-type: none"> ● Steady on: The link is connected. ● Blinking: The port is transmitting or receiving data.
		Off	The port is not connected.

Port Description

Figure 5-17 and **Figure 5-18** shows ports on the ES5D00X2SA00/ES5D00X4SA00.

Figure 5-17 Ports on the ES5D00X2SA00

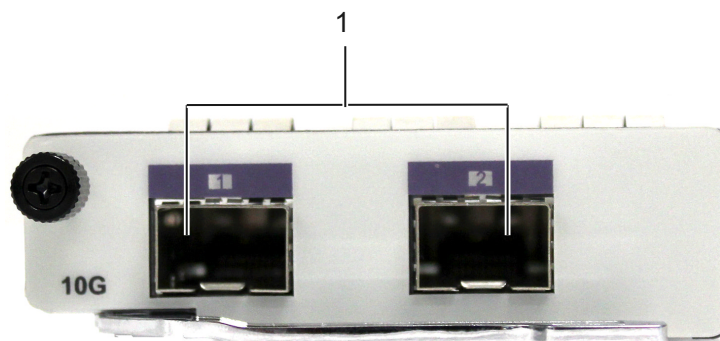
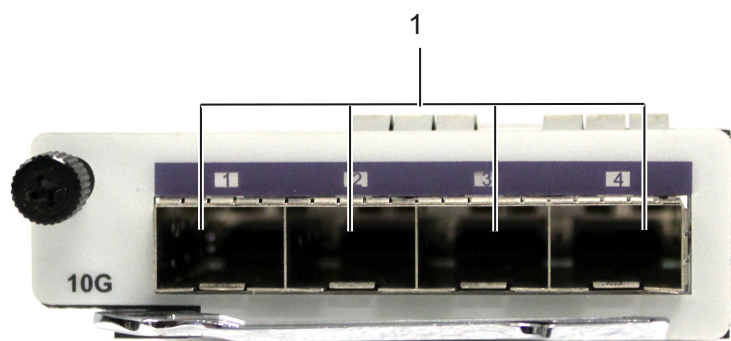

Figure 5-18 Ports on the ES5D00X4SA00



1. Two/Four 10GE SFP+ optical ports

10GE SFP+ optical port

The ES5D00X2SA00/ES5D00X4SA00 provides two/four 10GE optical ports (auto-sensing GE ports) to transmit and receive Ethernet services at 1 Gbit/s or 10 Gbit/s. [Table 5-18](#) describes attributes of an SFP+ optical port.

 **NOTE**

Two/Four optical ports provided by the ES5D00X2SA00/ES5D00X4SA00 support the 10GE SFP+ optical module, GE optical module, GE copper module (used together with shielded network cables), and SFP+ cables.

Table 5-18 Attributes of an SFP+ optical port

Attribute	Description
Connector type	LC/PC
Optical port attribute	Depending on the optical module used on the port (see 7.2 SFP/eSFP Modules and 7.3 SFP+ Modules)
Standards compliance	IEEE 802.3ae
Frame format	Ethernet_II, Ethernet_SAP, Ethernet_SNAP
Network protocol	IP

5.4.5 Specifications

[Table 5-19](#) describes the specifications of the ES5D00X2SA00/ES5D00X4SA00.

Table 5-19 Specifications of the ES5D00X2SA00/ES5D00X4SA00

Parameter	Description
Physical specifications	<ul style="list-style-type: none">● Dimensions (W x D x H): 77 mm x 207 mm x 23 mm● Weight: 0.5 kg● Maximum power consumption<ul style="list-style-type: none">- ES5D00X2SA00: 7 W- ES5D00X4SA00: 10 W
Environment parameters	<ul style="list-style-type: none">● Operating temperature: -5°C to +55°C● Relative humidity: 10% RH to 90% RH● Storage temperature: -40°C to +70°C

Parameter	Description
EMC	<ul style="list-style-type: none">● CISPR22 Class A● CISPR24● EN55022 Class A● EN50024● ETSI EN 300 386 Class A● CFR 47 FCC Part 15 Class A● ICES 003 Class A● AS/NZS CISPR22 Class A● IEC61000-4-2● ITU-T K 20● ITU-T K 44
Environment standard	<ul style="list-style-type: none">● RoHS● REACH
Safety	<ul style="list-style-type: none">● IEC 60950-1● EN 60950-1/A11/A12● UL 60950-1● CSA C22.2 No 60950-1● AS/NZS 60950.1
Laser safety	<ul style="list-style-type: none">● IEC60825-1● IEC60825-2● EN60825-1● EN60825-2

5.4.6 Ordering Information

To order the card, contact the local Huawei sales representatives. To download software, visit the Huawei enterprise website: <http://enterprise.huawei.com>.

Table 5-20 lists the ES5D00X2SA00/ES5D00X4SA00 ordering information.

Table 5-20 ES5D00X2SA00/ES5D00X4SA00 ordering information

Card Description	Card Name
2-port GE SFP/10GE SFP+ front optical interface card	ES5D00X2SA00
4-port GE SFP/10GE SFP+ front optical interface card	ES5D00X4SA00

5.5 ES5D00G4SC00 (4-Port GE SFP Front Optical Interface Card)

5.5.1 Introduction

The ES5D00G4SC00 provides four 1000M SFP optical ports to implement data access and line-speed switching for upstream services.

The ES5D00G4SC00 can be inserted into the front card slot of the S5700-28C-HI or S5700-28C-HI-24S.

Figure 5-19 shows the appearance of the ES5D00G4SC00.

Figure 5-19 Appearance of the ES5D00G4SC00



5.5.2 Version Mapping

Table 5-21 lists the switch chassis and software versions matching the ES5D00G4SC00.

Table 5-21 Version mapping

Card Name	Card Description
ES5D00G4SC00	Supported in V100R006C01 and later versions

5.5.3 Functions and Features

Table 5-22 describes the functions and features of the ES5D00G4SC00.

Table 5-22 Functions and features of the ES5D00G4SC00

Functions and Features	Description
Basic function	The ES5D00G4SC00 provides four 1000M SFP optical ports to implement data access and line-speed switching for upstream services.
Enhanced service	The S5700-HI powers on or off the ES5D00G4SC00, detects whether the ES5D00G4SC00 is installed or not, and manages PHY chips and optical ports on the ES5D00G4SC00. The ES5D00G4SC00 works with the entire system to provide enhanced service features such as OAM and BFD.
Hot swap	Supported

5.5.4 Indicators and Ports

Indicator Description

Figure 5-20 shows indicators on the ES5D00G4SC00.

Figure 5-20 Indicators on the ES5D00G4SC00

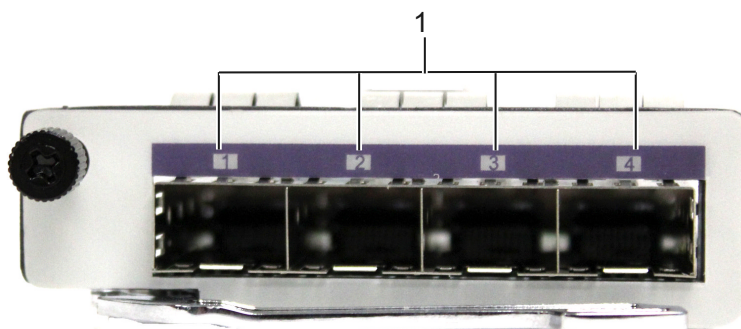

Table 5-23 shows indicators on the ES5D00G4SC00.

Table 5-23 Description of indicators on the ES5D00G4SC00

Number	Indicator	Color	Description
1	ACT/LINK	Green	<ul style="list-style-type: none"> ● Steady on: The link is connected. ● Blinking: The port is transmitting or receiving data.
		Off	The port is not connected.

Port Description

Figure 5-21 shows ports on the ES5D00G4SC00.

Figure 5-21 Ports on the ES5D00G4SC00

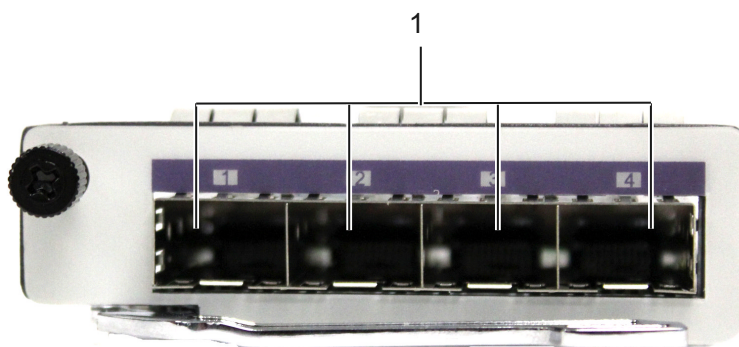

1. Four GE SFP optical ports

GE SFP optical port

The ES5D00G4SC00 provides four 1000M optical ports to transmit and receive Ethernet services only at 1000 Mbit/s. **Table 5-24** describes attributes of an SFP optical port.

NOTE

Four optical ports provided by the ES5D00G4SC00 support the GE optical module and GE copper module (used together with shielded network cables).

Table 5-24 Attributes of an SFP optical port

Attribute	Description
Connector type	LC/PC
Optical port attribute	Depending on the optical module used on the port (see 7.2 SFP/eSFP Modules)
Standards compliance	IEEE 802.3z

Attribute	Description
Frame format	Ethernet_II, Ethernet_SAP, Ethernet_SNAP
Network protocol	IP

5.5.5 Specifications

Table 5-25 lists the specifications of the ES5D00G4SC00.

Table 5-25 Specifications of the ES5D00G4SC00

Parameter	Description
Physical specifications	<ul style="list-style-type: none">● Dimensions (W x D x H): 77 mm x 207 mm x 23 mm● Weight: 0.3 kg● Maximum power consumption: 4 W
Environment parameters	<ul style="list-style-type: none">● Operating temperature: -5°C to +55°C● Relative humidity: 10% RH to 90% RH● Storage temperature: -40°C to +70°C
EMC	<ul style="list-style-type: none">● CISPR22 Class A● CISPR24● EN55022 Class A● EN50024● ETSI EN 300 386 Class A● CFR 47 FCC Part 15 Class A● ICES 003 Class A● AS/NZS CISPR22 Class A● IEC61000-4-2● ITU-T K 20● ITU-T K 44
Environment standard	<ul style="list-style-type: none">● RoHS● REACH
Safety	<ul style="list-style-type: none">● IEC 60950-1● EN 60950-1/A11/A12● UL 60950-1● CSA C22.2 No 60950-1● AS/NZS 60950.1

Parameter	Description
Laser safety	<ul style="list-style-type: none">● IEC60825-1● IEC60825-2● EN60825-1● EN60825-2

5.5.6 Ordering Information

To order the card, contact the local Huawei sales representatives. To download software, visit the Huawei enterprise website: <http://enterprise.huawei.com>.

Table 5-26 lists the ES5D00G4SC00 ordering information.

Table 5-26 ES5D00G4SC00 ordering information

Card Description	Card Name
4-port GE SFP front optical interface card	ES5D00G4SC00

5.6 ES5D21G08S00 (8-Port GE SFP Rear Optical Interface Card)

5.6.1 Introduction

The ES5D21G08S00 provides eight 1000M SFP optical ports to implement data access and line-speed switching for GE services.

The ES5D21G08S00 can be inserted into the rear card slot of the S5710-52C-PWR-EI, S5710-52C-PWR-EI-AC, S5710-28C-PWR-EI-AC, S5710-52C-EI, or S5710-28C-EI.

Figure 5-22 shows the appearance of the ES5D21G08S00.

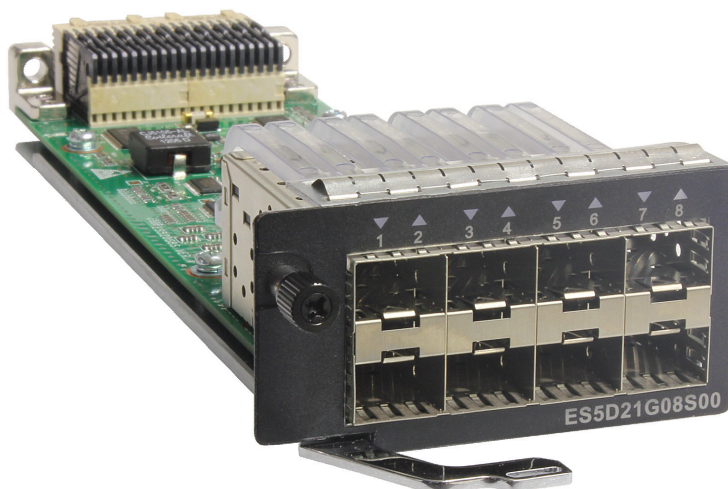
Figure 5-22 Appearance of the ES5D21G08S00

5.6.2 Version Mapping

Table 5-27 lists the switch chassis and software versions matching the ES5D21G08S00.

Table 5-27 Version mapping

Card Name	Card Description
ES5D21G08S00	Supported in V200R001C00 and later versions.

5.6.3 Functions and Features

Table 5-28 describes the functions and features of the ES5D21G08S00.

Table 5-28 Functions and features of the ES5D21G08S00

Functions and Features	Description
Basic function	The ES5D21G08S00 provides eight 1000M SFP optical ports to implement data access and line-speed switching for GE services.
Hot swap	Supported

5.6.4 Indicators and Ports

Indicator Description

Figure 5-23 shows indicators on the ES5D21G08S00.

Figure 5-23 Indicators on the ES5D21G08S00

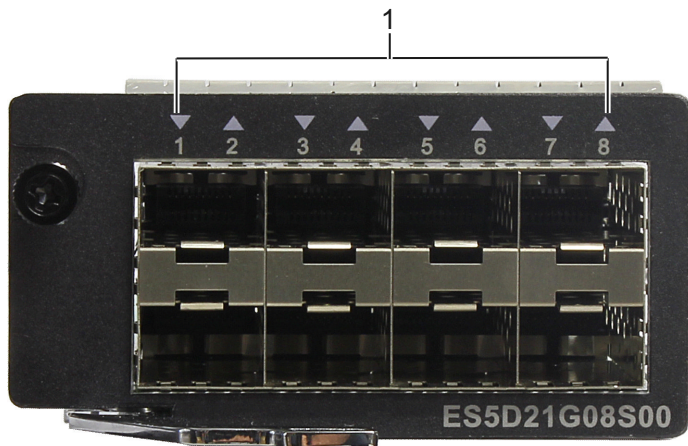

Table 5-29 shows indicators on the ES5D21G08S00.

Table 5-29 Description of indicators on the ES5D21G08S00

Number	Indicator	Color	Description
1	ACT/LINK	Green	<ul style="list-style-type: none"> ● Steady on: The link is connected. ● Blinking: The port is transmitting or receiving data.
		Off	The port is not connected.

Port Description

Figure 5-24 shows ports on the ES5D21G08S00.

Figure 5-24 Ports on the ES5D21G08S00

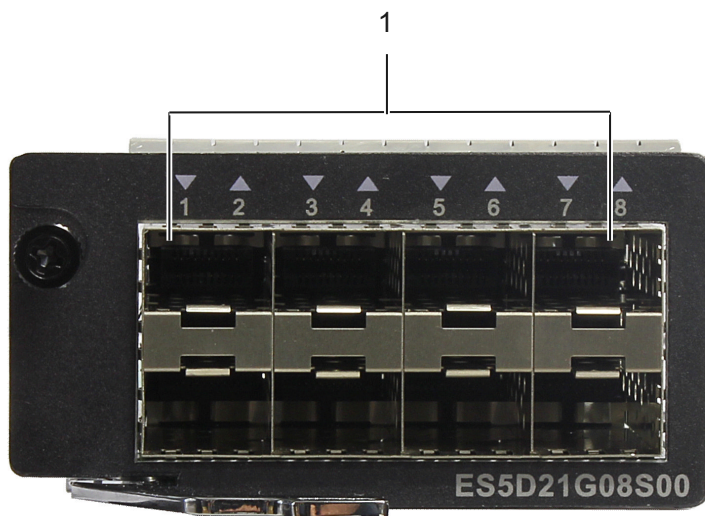

1. Eight GE SFP optical ports

GE SFP optical port

The ES5D21G08S00 provides eight 1000M optical ports to transmit and receive services at 1000 Mbit/s. [Table 5-30](#) describes attributes of an SFP optical port.

 **NOTE**

Eight optical ports provided by the ES5D21G08S00 support only the GE optical module.

Table 5-30 Attributes of an SFP optical port

Attribute	Description
Connector type	LC/PC
Optical port attribute	Depending on the optical module used on the port (see 7.2 SFP/eSFP Modules)
Standards compliance	IEEE 802.3z
Frame format	Ethernet_II, Ethernet_SAP, Ethernet_SNAP
Network protocol	IP

5.6.5 Specifications

[Table 5-31](#) lists the specifications of the ES5D21G08S00.

Table 5-31 Specifications of the ES5D21G08S00

Parameter	Description
Physical specifications	<ul style="list-style-type: none">● Dimensions (W x D x H): 77 mm x 207 mm x 42 mm● Weight: 0.3 kg● Maximum power consumption: 10.9 W
Environment parameters	<ul style="list-style-type: none">● Operating temperature: 0°C to 50°C● Relative humidity: 5% RH to 95% RH● Storage temperature: -40°C to +70°C
EMC	<ul style="list-style-type: none">● CISPR22 Class A● CISPR24● EN55022 Class A● EN50024● ETSI EN 300 386 Class A● CFR 47 FCC Part 15 Class A● ICES 003 Class A● AS/NZS CISPR22 Class A● IEC61000-4-2● ITU-T K 20● ITU-T K 44
Environment standard	<ul style="list-style-type: none">● RoHS● REACH
Safety	<ul style="list-style-type: none">● IEC 60950-1● EN 60950-1/A11/A12● UL 60950-1● CSA C22.2 No 60950-1● AS/NZS 60950.1
Laser safety	<ul style="list-style-type: none">● IEC60825-1● IEC60825-2● EN60825-1● EN60825-2

5.6.6 Ordering Information

To order the card, contact the local Huawei sales representatives. To download software, visit the Huawei enterprise website: <http://enterprise.huawei.com>.

Table 5-32 lists the ES5D21G08S00 ordering information.

Table 5-32 ES5D21G08S00 ordering information

Card Description	Card Name
8-port GE SFP rear optical interface card	ES5D21G08S00

5.7 ES5D21G08T00 (8-Port GE Rear Electrical Interface Card)

5.7.1 Introduction

The ES5D21G08T00 provides eight 10M/100M/1000M electrical ports to implement data access and line-speed switching for services.

The ES5D21G08T00 can be inserted into the rear card slot of the S5710-52C-PWR-EI, S5710-52C-PWR-EI-AC, S5710-28C-PWR-EI-AC, S5710-52C-EI, or S5710-28C-EI.

Figure 5-25 shows the appearance of the ES5D21G08T00.

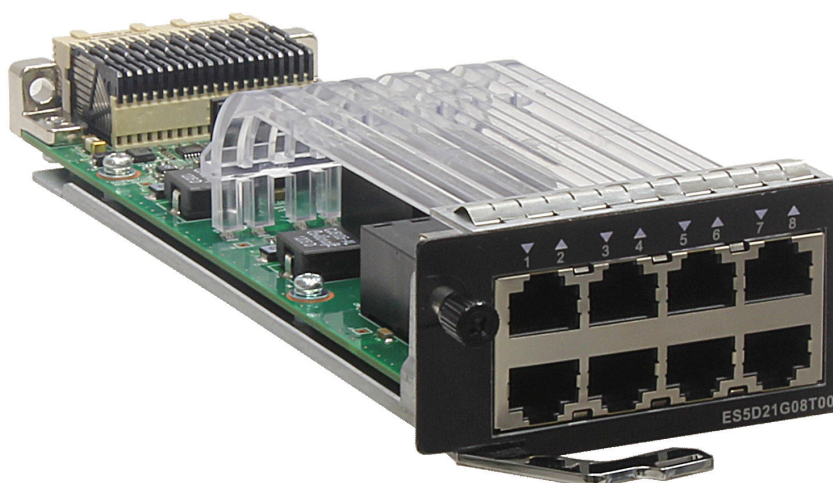
Figure 5-25 Appearance of the ES5D21G08T00

5.7.2 Version Mapping

Table 5-33 lists the switch chassis and software versions matching the ES5D21G08T00.

Table 5-33 Version mapping

Card Name	Card Description
ES5D21G08T00	Supported in V200R001C00 and later versions.

5.7.3 Functions and Features

Table 5-34 describes the functions and features of the ES5D21G08T00.

Table 5-34 Functions and features of the ES5D21G08T00

Functions and Features	Description
Basic function	The ES5D21G08T00 provides eight 10M/100M/1000M electrical ports to implement data access and line-speed switching for services.
Hot swap	Supported

5.7.4 Indicators and Ports

Indicator Description

Figure 5-26 shows indicators on the ES5D21G08T00.

Figure 5-26 Indicators on the ES5D21G08T00

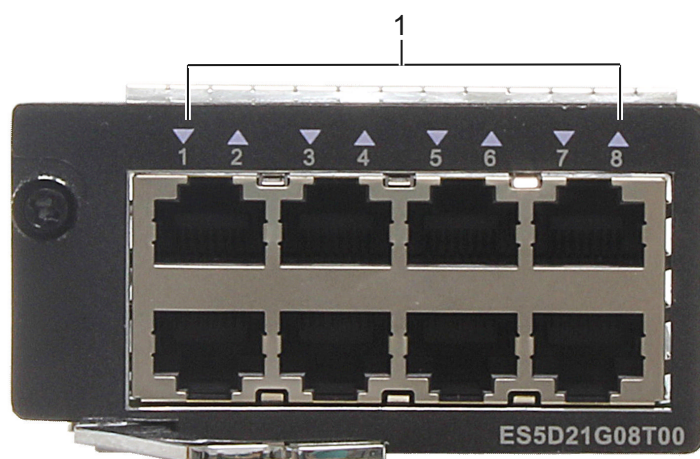

Table 5-35 shows indicators on the ES5D21G08T00.

Table 5-35 Description of indicators on the ES5D21G08T00

Number	Indicator	Color	Description
1	ACT/LINK	Green	<ul style="list-style-type: none"> ● Steady on: The link is connected. ● Blinking: The port is transmitting or receiving data.
		Off	The port is not connected.

Port Description

Figure 5-27 shows ports on the ES5D21G08T00.

Figure 5-27 Ports on the ES5D21G08T00

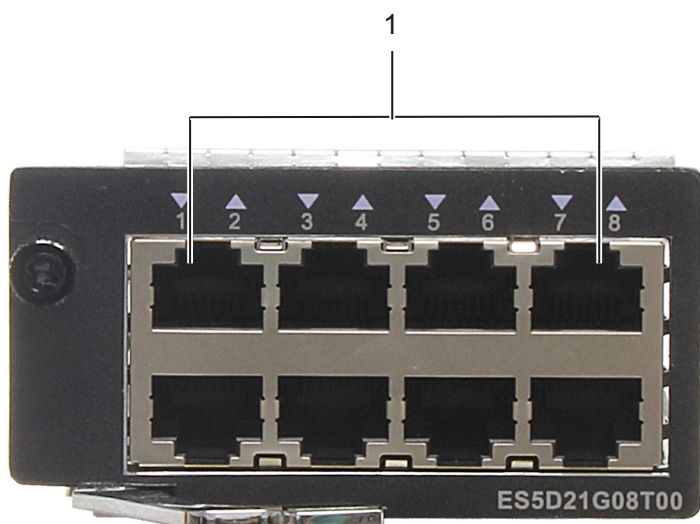

1. Eight 10M/100M/1000M BASE-T electrical ports

10M/100M/1000M BASE-T electrical port

The ES5D21G08T00 provides eight 10M/100M/1000M Ethernet electrical ports to transmit and receive Ethernet services. The eight 10M/100M/1000M Ethernet electrical ports must be used with **6.4 Network Cable**. **Table 5-36** describes attributes of the 10M/100M/1000M BASE-T electrical port.

Table 5-36 Attributes of the 10M/100M/1000M Base-T electrical port

Attribute	Description
Connector type	RJ45

Attribute	Description
Electrical port attribute	MDI/MDIX NOTE <ul style="list-style-type: none"> ● The interfaces of most network cards are medium dependent interfaces (MDIs). ● MDIX interfaces are used on hubs or LAN switches.
Standards compliance	IEEE802.3, IEEE802.3u, and IEEE802.3ab
Frame format	Ethernet_II, Ethernet_SAP, Ethernet_SNAP
Network protocol	IP

5.7.5 Specifications

[Table 5-37](#) lists the specifications of the ES5D21G08T00.

Table 5-37 Specifications of the ES5D21G08T00

Parameter	Description
Physical specifications	<ul style="list-style-type: none"> ● Dimensions (W x D x H): 77 mm x 207 mm x 42 mm ● Weight: 0.3 kg ● Maximum power consumption: 10.9 W
Environment parameters	<ul style="list-style-type: none"> ● Operating temperature: 0°C to 50°C ● Relative humidity: 5% RH to 95% RH ● Storage temperature: -40°C to +70°C
EMC	<ul style="list-style-type: none"> ● CISPR22 Class A ● CISPR24 ● EN55022 Class A ● EN50024 ● ETSI EN 300 386 Class A ● CFR 47 FCC Part 15 Class A ● ICES 003 Class A ● AS/NZS CISPR22 Class A ● IEC61000-4-2 ● ITU-T K 20 ● ITU-T K 44
Environment standard	<ul style="list-style-type: none"> ● RoHS ● REACH

Parameter	Description
Safety	<ul style="list-style-type: none">● IEC 60950-1● EN 60950-1/A11/A12● UL 60950-1● CSA C22.2 No 60950-1● AS/NZS 60950.1

5.7.6 Ordering Information

To order the card, contact the local Huawei sales representatives. To download software, visit the Huawei enterprise website: <http://enterprise.huawei.com>.

Table 5-38 lists the ES5D21G08T00 ordering information.

Table 5-38 ES5D21G08T00 ordering information

Card Description	Card Name
8-port GE rear electrical interface card	ES5D21G08T00

5.8 ES5D21X02S00 (2-Port GE SFP/10GE SFP+ Rear Optical Interface Card)

5.8.1 Introduction

The ES5D21X02S00 provides two 10GE SFP+ optical ports to implement data access and line-speed switching.

The ES5D21X02S00 can be inserted into the rear card slot of the S5710-52C-PWR-EI, S5710-52C-PWR-EI-AC, S5710-28C-PWR-EI-AC, S5710-52C-EI, or S5710-28C-EI.

Figure 5-28 shows the appearance of the ES5D21X02S00.

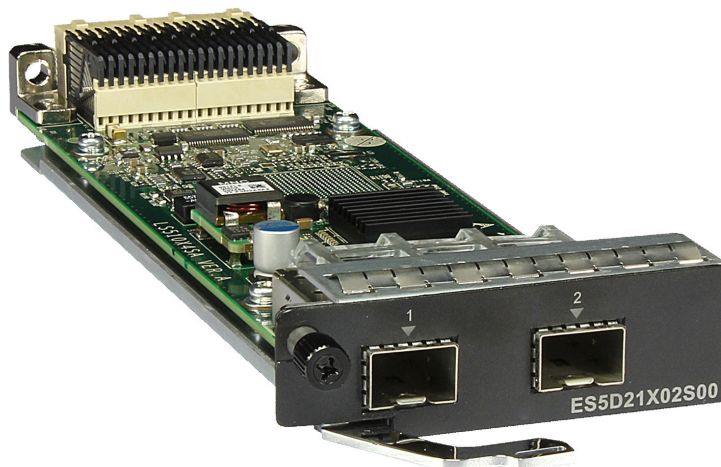
Figure 5-28 Appearance of the ES5D21X02S00

5.8.2 Version Mapping

Table 5-39 lists the switch chassis and software versions matching the ES5D21X02S00.

Table 5-39 Version mapping

Card Name	Card Description
ES5D21X02S00	Supported in V200R001C00 and later versions

5.8.3 Functions and Features

Table 5-40 describes the functions and features of the ES5D21X02S00.

Table 5-40 Functions and features of the ES5D21X02S00

Functions and Features	Description
Basic function	The ES5D21X02S00 provides two 10GE SFP+ optical ports to implement data access and line-speed switching.
Hot swap	Supported
Service port supporting the stack function	The ES5D21X02S00 can be used on the service stack port of the switch.

5.8.4 Indicators and Ports

Indicator Description

Figure 5-29 shows indicators on the ES5D21X02S00.

Figure 5-29 Indicators on the ES5D21X02S00

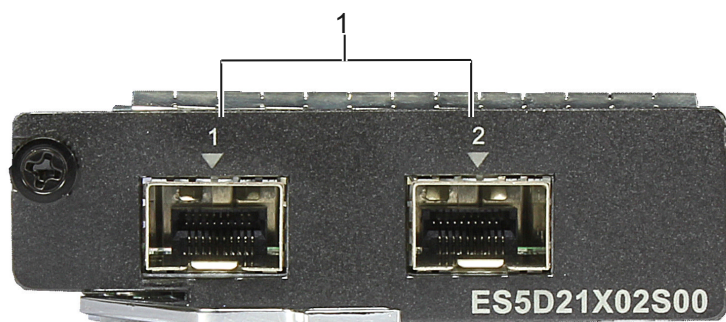

Table 5-41 shows indicators on the ES5D21X02S00.

Table 5-41 Description of indicators on the ES5D21X02S00

Number	Indicator	Color	Description
1	ACT/LINK	Green	<ul style="list-style-type: none"> ● Steady on: The link is connected. ● Blinking: The port is transmitting or receiving data.
		Off	The port is not connected.

Port Description

Figure 5-30 shows ports on the ES5D21X02S00.

Figure 5-30 Ports on the ES5D21X02S00

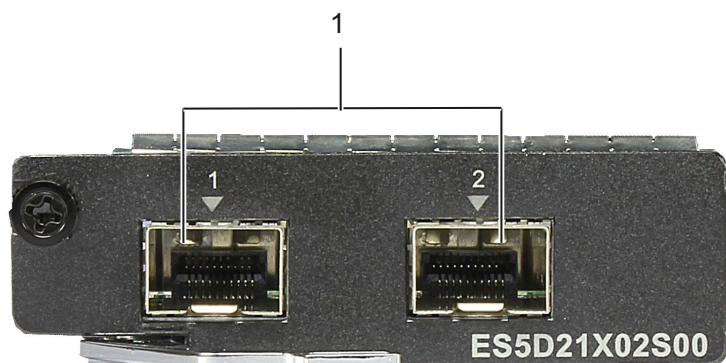

1. Two 10GE SFP+ optical ports

10GE SFP+ optical port

The ES5D21X02S00 provides two 10GE optical ports (auto-sensing GE ports) to transmit and receive Ethernet services at 1 Gbit/s or 10 Gbit/s. [Table 5-42](#) describes attributes of an SFP+ optical port.

 **NOTE**

Two optical ports provided by the ES5D21X02S00 support the 10GE SFP+ optical module, GE SFP optical module, GE copper module (used together with shielded network cables), and SFP+ cable.

Table 5-42 Attributes of an SFP+ optical port

Attribute	Description
Connector type	LC/PC
Optical port attribute	Depending on the optical module used on the port (see 7.2 SFP/eSFP Modules and 7.3 SFP+ Modules)
Standards compliance	IEEE 802.3ae
Frame format	Ethernet_II, Ethernet_SAP, Ethernet_SNAP
Network protocol	IP

5.8.5 Specifications

[Table 5-43](#) lists the specifications of the ES5D21X02S00.

Table 5-43 Specifications of the ES5D21X02S00

Parameter	Description
Physical specifications	<ul style="list-style-type: none">● Dimensions (W x D x H): 77 mm x 207 mm x 23 mm● Weight: 0.5 kg● Maximum power consumption: 7 W
Environment parameters	<ul style="list-style-type: none">● Operating temperature: 0°C to 50°C● Relative humidity: 5% RH to 95% RH● Storage temperature: -40°C to +70°C

Parameter	Description
EMC	<ul style="list-style-type: none">● CISPR22 Class A● CISPR24● EN55022 Class A● EN50024● ETSI EN 300 386 Class A● CFR 47 FCC Part 15 Class A● ICES 003 Class A● AS/NZS CISPR22 Class A● IEC61000-4-2● ITU-T K 20● ITU-T K 44
Environment standard	<ul style="list-style-type: none">● RoHS● REACH
Safety	<ul style="list-style-type: none">● IEC 60950-1● EN 60950-1/A11/A12● UL 60950-1● CSA C22.2 No 60950-1● AS/NZS 60950.1
Laser safety	<ul style="list-style-type: none">● IEC60825-1● IEC60825-2● EN60825-1● EN60825-2

5.8.6 Ordering Information

To order the card, contact the local Huawei sales representatives. To download software, visit the Huawei enterprise website: <http://enterprise.huawei.com>.

Table 5-44 lists the ES5D21X02S00 ordering information.

Table 5-44 ES5D21X02S00 ordering information

Card Description	Card Name
2-port GE SFP/10GE SFP+ rear optical interface card	ES5D21X02S00

5.9 ES5D00ETPC00 (Stack Rear Card)

5.9.1 Introduction

Intelligent Stack (iStack) is a technology that enables multiple stacking-capable devices to function as a logical device.

Before a stack is set up, each switch is an independent entity and has its own IP address and MAC address. You need to manage the switches separately. After a stack is set up, switches in the stack form a logical entity and can be managed and maintained using a single IP address. iStack technology improves forwarding performance and network reliability, and simplifies network management.

Switches can set up a stack using service ports or stack cards.

The ES5D00ETPC00 stack card can be installed in the rear subcard slot of the following switch models to set up a stack: S5700-24TP-SI-AC, S5700-24TP-SI-DC, S5700-48TP-SI-AC, S5700-48TP-SI-DC, S5700-28C-EI, S5700-52C-EI, S5700-28C-EI-24S, S5700-28C-SI, S5700-52C-SI, S5700-28C-PWR-SI, S5700-52C-PWR-SI, S5700-24TP-PWR-SI, S5700-48TP-PWR-SI, S5700-28C-PWR-EI, and S5700-52C-PWR-EI.

Figure 5-31 shows the appearance of the ES5D00ETPC00.

Figure 5-31 Appearance of the ES5D00ETPC00



5.9.2 Version Mapping

Table 5-45 lists the switch chassis and software versions matching the ES5D00ETPC00.

Table 5-45 Version mapping

Card Name	Card Description
ES5D00ETPC00	Supported in V100R005C01 and later versions

5.9.3 Functions and Features

Table 5-46 describes functions and features of the ES5D00ETPC00.

Table 5-46 Functions and features of the ES5D00ETPC00

Function and Feature	Description
Basic functions	The ES5D00ETPC00 provides two 12 Gbit/s electrical ports for stacking. The 12 Gbit/s electrical ports on multiple switches are connected using PCIe cables to set up a stack, providing a maximum of 48 Gbit/s bidirectional stack bandwidth. A maximum of nine switches can set up a stack using ES5D00ETPC00 stack cards.
Topology	Switches in a stack can be connected in a chain or ring topology. A link failure in the chain topology causes the stack to split, whereas the ring topology changes into a chain topology upon a link failure so that services in the stack are not affected. Therefore, the ring topology is more reliable than the chain topology. Figure 5-32 and Figure 5-33 show the chain and ring topologies. NOTE When connecting stack cables, connect stack1 port of one switch to stack2 port of another switch.
Hot swap	The ES5D00ETPC00 does not support hot swap, and PCIe cables support hot swap.

Figure 5-32 Chain topology of a stack



Figure 5-33 Ring topology of a stack

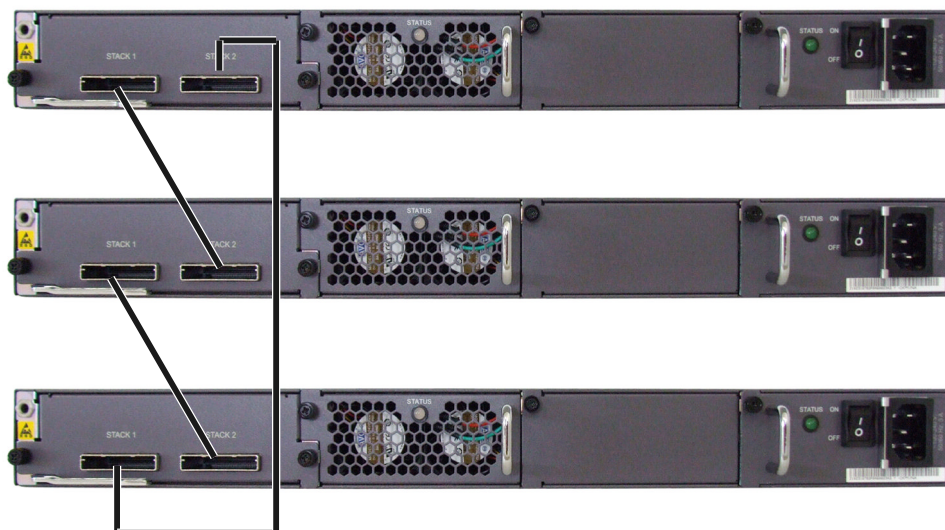

5.9.4 Usage Constraints



CAUTION

The following requirements must be met to set up a stack:

- All the member switches belong to the same series. The EI series and SI series cannot form a stack.
- All switches have stack cards installed and are connected using PCIe cables.

5.9.5 Port Description

Figure 5-34 shows ports on the ES5D00ETPC00.

Figure 5-34 Ports on the ES5D00ETPC00

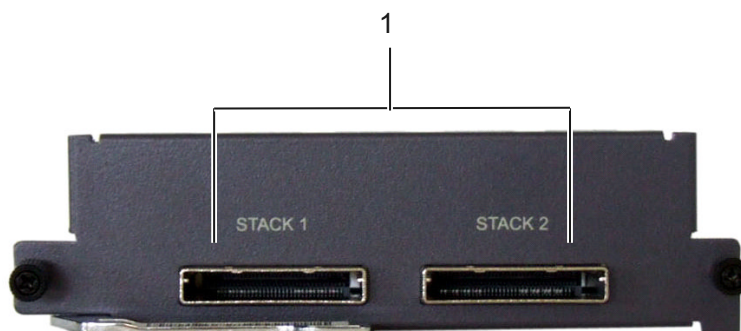

1. Two stack electrical ports

Stack electrical port

The ES5D00ETPC00 provides two 12Gbit/s electrical ports for stacking. The two 12Gbit/s electrical ports must be used with [6.2 Stack Cable](#). [Table 5-47](#) describes attributes of the 12Gbit/s electrical port.

Table 5-47 Attributes of the stack electrical interface

Attribute	Description
Connector type	PCI-E
Standards compliance	IEEE 802.3ae
Frame format	Ethernet_II, Ethernet_SAP, Ethernet_SNAP
Network protocol	IP

5.9.6 Specifications

[Table 5-48](#) lists the specifications of the ES5D00ETPC00.

Table 5-48 Specifications of the ES5D00ETPC00

Parameter	Description
Physical specifications	<ul style="list-style-type: none">● Dimensions (W x D x H): 143 mm x 126 mm x 43 mm● Weight: 0.2 kg● Maximum power consumption: 0.5 W
Environment parameters	<ul style="list-style-type: none">● Operating temperature: 0°C to 50°C● Relative humidity: 10% RH to 90% RH● Storage temperature: -40°C to +70°C

Parameter	Description
EMC	<ul style="list-style-type: none">● CISPR22 Class A● CISPR24● EN55022 Class A● EN50024● ETSI EN 300 386 Class A● CFR 47 FCC Part 15 Class A● ICES 003 Class A● AS/NZS CISPR22 Class A● IEC61000-4-2● ITU-T K 20● ITU-T K 44
Environment standard	<ul style="list-style-type: none">● RoHS● REACH
Safety	<ul style="list-style-type: none">● IEC 60950-1● EN 60950-1/A11/A12● UL 60950-1● CSA C22.2 No 60950-1● AS/NZS 60950.1

5.9.7 Ordering Information

To order the card, contact the local Huawei sales representatives. To download software, visit the Huawei enterprise website: <http://enterprise.huawei.com>.

Table 5-49 lists the card ordering information.

Table 5-49 ES5D00ETPC00 ordering information

Card Description	Card Name
Ethernet Stack Interface Card (Including Stack Card, 100cm Stack Cable)	ES5D001VST00

5.10 ES5D00ETPB00 (Extended Rear Card)

5.10.1 Introduction

The ES5D00ETPB00 can be installed on the S5700-28C-PWR-SI, S5700-52C-PWR-SI, S5700-28C-EI, S5700-52C-EI, S5700-28C-EI-24S, S5700-28C-SI, S5700-52C-SI, S5700-28C-PWR-EI, and S5700-52C-PWR-EI for port extension.

Figure 5-35 shows the appearance of the ES5D00ETPB00.

Figure 5-35 Appearance of the ES5D00ETPB00



5.10.2 Version Mapping

Table 5-50 lists the switch chassis and software versions matching the ES5D00ETPB00.

Table 5-50 Version mapping

Card Name	Card Description
ES5D00ETPB00	Supported in V100R005C01 and later versions

5.10.3 Functions and Features

Table 5-51 describes the functions and features of the ES5D00ETPB00.

Table 5-51 Functions and features of the ES5D00ETPB00

Functions and Features	Description
Basic function	The ES5D00ETPB00 extended rear card must be used together with the ES5D000X4S01/ES5D000G4S01/ES5D00G4SA01 front card to provide four GE SFP ports or four 10GE SFP+ ports.
Hot swap	Not supported

5.10.4 Usage Constraints



CAUTION

The ES5D000X4S01/ES5D000G4S01/ES5D00G4SA01 front card must be used with an ES5D00ETPB00 extended rear card.

5.10.5 Specifications

Table 5-52 lists the specifications of the ES5D00ETPB00.

Table 5-52 Specifications of the ES5D00ETPB00

Parameter	Description
Physical specifications	<ul style="list-style-type: none"> ● Dimensions (W x D x H): 143 mm x 126 mm x 43 mm ● Weight: 0.2 kg ● Maximum power consumption: 0.1 W
Environment parameters	<ul style="list-style-type: none"> ● Operating temperature: 0°C to 50°C ● Relative humidity: 10% RH to 90% RH ● Storage temperature: -40°C to +70°C
EMC	<ul style="list-style-type: none"> ● CISPR22 Class A ● CISPR24 ● EN55022 Class A ● EN50024 ● ETSI EN 300 386 Class A ● CFR 47 FCC Part 15 Class A ● ICES 003 Class A ● AS/NZS CISPR22 Class A ● IEC61000-4-2 ● ITU-T K 20 ● ITU-T K 44
Environment standard	<ul style="list-style-type: none"> ● RoHS ● REACH
Safety	<ul style="list-style-type: none"> ● IEC 60950-1 ● EN 60950-1/A11/A12 ● UL 60950-1 ● CSA C22.2 No 60950-1 ● AS/NZS 60950.1

5.10.6 Ordering Information

To order the card, contact the local Huawei sales representatives. To download software, visit the Huawei enterprise website: <http://enterprise.huawei.com>.

Table 5-53 lists the ES5D00ETPB00 ordering information.

Table 5-53 ES5D00ETPB00 ordering information

Card Description	Card Name
Extended channel card	ES5D00ETPB00

6 Cables

About This Chapter

- 6.1 Ground Cable
- 6.2 Stack Cable
- 6.3 Optical Fiber
- 6.4 Network Cable
- 6.5 DC Power Cable
- 6.6 AC Power Cable
- 6.7 RPS1800 Power Cable
- 6.8 RPS Cable
- 6.9 Console Cable

6.1 Ground Cable

Appearance and Structure

Figure 6-1 shows the appearance of a ground cable.

 **NOTE**

Different types of ground cables have similar appearance, except for the cross-sectional area, size of the cable lugs, and cable length. The following figure is for reference.

Figure 6-1 Appearance of a ground cable



Connection

A ground cable grounds a switch. One end of the ground cable connects to the ground screw on the switch chassis, and the other end connects to the ground point on the cabinet or ground bar.

6.2 Stack Cable

Types of Stack Cables

The S5700 uses the PCIe or SFP+ cable to connect to the stack port on the stack rear card or a specified port on the switch. Switches connected by stack cables form a logical switch to forward packets.

 **NOTE**

The two ends of a stack cable are covered by the ESD caps.

Appearance and Structure

Figure 6-2 and **Figure 6-3** show the structure of a stack cable.

Figure 6-2 Structure of a PCIe cable



Figure 6-3 Structure of an SFP+ cable



Specifications

Table 6-1 Specifications of a PCIe cable

Item	Description	
Cable type	1.0 m PCIe cable	3.0 m PCIe cable

Item	Description	
Connector type	PCIe	
Standards compliance	PCIe 8X	
Length	1.0 m	3.0 m
Applicable device when the cable is used for stacking	<ul style="list-style-type: none"> ● S5700-SI ● S5700-EI 	S5700-52C-EI and S5700-28C-EI-24S

Table 6-2 Specifications of an SFP+ stack cable

Item	Description		
Cable model	SFP+ High-Speed Transmission Cable-1m-(SFP+20M)-(CC2P0.254 Black)-(SFP+20M)-Indoor	SFP+ High-Speed Transmission Cable-3m-(SFP+20M)-(CC2P0.254 Black)-(SFP+20M)-Indoor	SFP+ Active High-Speed Transmission Cable-10m-(SFP+20M)-(CC2P0.32 Black)-(SFP+20M)-Indoor
Length	1.0 m	3.0 m	10.0 m
Bend radius	25 mm	25 mm	25 mm
Electrical characteristic	Passive	Passive	Active
Connector X1/X2	SFP+, 20-pin, male		
Color	Black		
Pin	2 pairs		
Applicable device when the cable is used for stacking	<ul style="list-style-type: none"> ● S5700-P-LI (GE uplink ports) ● S5700-TP-LI (GE uplink ports) ● S5700-X-LI (10GE uplink ports) ● S5710-EI 	<ul style="list-style-type: none"> ● S5700-X-LI (10GE uplink ports) ● S5710-EI 	<ul style="list-style-type: none"> ● S5700-P-LI (GE uplink ports) ● S5700-TP-LI (GE uplink ports) ● S5700-X-LI (10GE uplink ports) ● S5710-EI

Stack Description

Table 6-3 Stack description

Device Series	Stacking Method	Ports Supporting Stack	Stack Cable	Rate of a Single Physical Stack Member Port	Remarks
S5700-P-LI (GE uplink ports)	Stack using service ports	<ul style="list-style-type: none"> ● V200R001: last two SFP ports ● V200R002 and later versions: Four SFP ports 	<ul style="list-style-type: none"> ● 1 m passive SFP+ cable ● 10 m active SFP+ cable 	<ul style="list-style-type: none"> ● 2.5 Gbit/s for the 1 m passive SFP+ cable ● 5 Gbit/s for the 10 m active SFP+ cable 	<ul style="list-style-type: none"> ● V200R001: A switch supports a maximum of two stack ports, and each stack port supports a maximum of one physical member port. A switch supports a maximum of two physical member ports. ● V200R002 and later versions: A switch supports a maximum of two stack ports, and each stack port supports a maximum of two physical member ports. A switch supports a maximum of four physical member ports. <p>Different models of switches with GE uplink ports can form a stack. However, switches with GE uplink ports and switches with 10GE uplink ports cannot form a stack.</p> <p>NOTE The S5700-10P-LI-AC and S5700-10P-PWR-LI-AC do not support the stack function.</p>

Device Series	Stacking Method	Ports Supporting Stack	Stack Cable	Rate of a Single Physical Stack Member Port	Remarks
S5700-TP-LI (GE uplink ports)	Stack using service ports	Two SFP ports	<ul style="list-style-type: none"> ● 1 m passive SFP+ cable ● 10 m active SFP+ cable 	<ul style="list-style-type: none"> ● 2.5 Gbit/s for the 1 m passive SFP+ cable ● 5 Gbit/s for the 10 m active SFP+ cable 	A switch supports a maximum of two stack ports, and each stack port supports a maximum of one physical member ports. A switch supports a maximum of two physical member ports. Different models of switches with GE uplink ports can form a stack. However, switches with GE uplink ports and switches with 10GE uplink ports cannot form a stack.
S5700-X-LI (10GE uplink ports)	Stack using service ports	Four SFP+ ports	<ul style="list-style-type: none"> ● 1 m passive SFP+ cable ● 3 m passive SFP+ cable ● 10 m active SFP+ cable ● Common SFP+ optical module and its optical fiber 	10 Gbit/s	A switch supports a maximum of two stack ports, and each stack port supports a maximum of two physical member ports. A switch supports a maximum of four physical member ports. Different models of switches with 10GE uplink ports can form a stack. However, switches with GE uplink ports and switches with 10GE uplink ports cannot form a stack.
S5700-SI	Stack using stack cards	Two stack ports on the stack card	1 m PCIe cable	12 Gbit/s	PoE and non-PoE models of the S5700-SI can form a stack. NOTE The S5700-26X-SI-12S-AC does not support the stack function.

Device Series	Stacking Method	Ports Supporting Stack	Stack Cable	Rate of a Single Physical Stack Member Port	Remarks
S5700-EI	Stack using stack cards	Two stack ports on the stack card	<ul style="list-style-type: none"> ● 1 m PCIe cable ● 3 m PCIe cable (applicable only to the S5700-52C-EI and S5700-28C-EI-24S) 	12 Gbit/s	PoE and non-PoE models of the S5700-EI can form a stack.
S5710-EI	Stack using service ports	All 10GE ports on the switch, including four front SFP+ ports and ports on the rear SFP+ card. A switch supports a maximum of two rear cards with each card supports two 10GE ports.	<ul style="list-style-type: none"> ● 1 m passive SFP+ cable ● 3 m passive SFP+ cable ● 10 m active SFP+ cable ● Common SFP+ optical module and its optical fiber 	10 Gbit/s	<ul style="list-style-type: none"> ● V200R001: A switch supports a maximum of two stack ports, and each stack port supports a maximum of three physical member ports. However, a switch supports a maximum of four physical member ports. All the physical member ports must be on the front panel or rear cards. ● V200R002 and later versions: A switch supports a maximum of two stack ports, and each stack port supports a maximum of four physical member ports. A switch supports a maximum of eight physical member ports. <p>Different models of the S5710-EI can form a stack.</p>

Device Series	Stacking Method	Ports Supporting Stack	Stack Cable	Rate of a Single Physical Stack Member Port	Remarks
S5700-HI	The stack function is not supported.				
S5700-S-LI					

6.3 Optical Fiber

Types of Optical Fibers

Table 6-4 lists the types of optical fibers.

Table 6-4 Types of optical fibers

No.	Purpose	Local End Connector	Remote End Connector	Cables
1	To connect LPU of the device to the ODF	LC/PC	FC/PC	Single-mode, indoor
2	To connect LPUs of two devices	LC/PC	LC/PC	Single-mode/multi-mode, indoor
3	To connect LPU of the device to another device	LC/PC	SC/PC or LC/PC	Single-mode/multi-mode, indoor

Appearance and Structure

A single-mode optical fiber and a multi-mode optical fiber have the same appearance but different colors. A single-mode optical fiber is yellow and a multi-mode optical fiber is orange blue.

Figure 6-4 shows the appearance of a single fiber.

Figure 6-4 Appearance of a single-mode optical fiber with LC/PC connectors



Figure 6-5 shows the appearance of a multi-mode fiber.

Figure 6-5 Appearance of a multi-mode fiber with LC/PC connectors

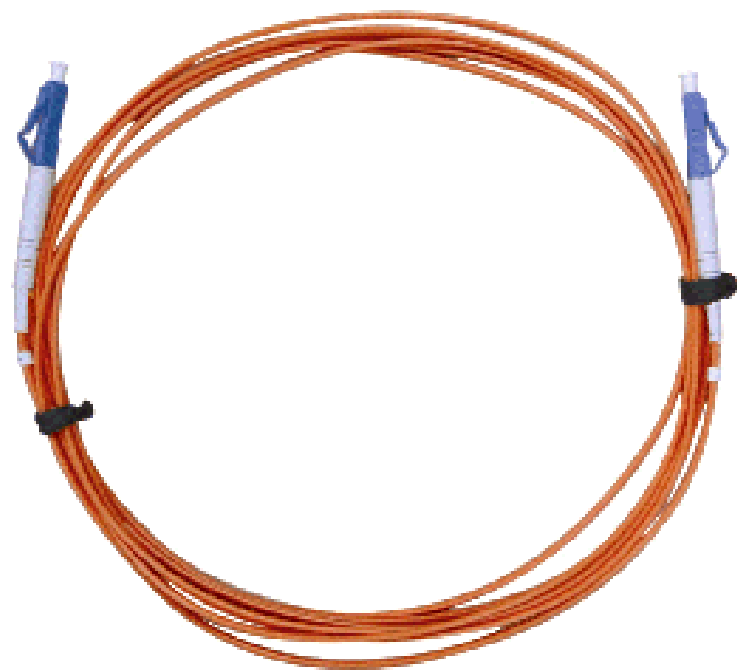

Connection

An optical fiber carries optical signals and transmits them over short distance. An optical fiber connects to the following:

- A switch or an optical port on the card
- An optical distribution frame (ODF), an upstream optical port, or an optical port of an ONT

Table 6-5 describes the pin assignments of an optical fiber.

Table 6-5 Pin assignments of an optical fiber

Local End Terminal	Signal Direction	Remote End Terminal
Optical interface Tx terminal	->	Optical interface Rx terminal
Optical interface Rx terminal	<-	Optical interface Tx terminal



CAUTION

When connecting or removing the LC/PC optical connector, align the connector with the optical port, and do not rotate the fiber. Pay attention to the following points:

- Align the head of the fiber jumper with the optical port and insert the optical fiber into the port gently.
- To remove the fiber, press the latch on the connector and pull the fiber out.





Optical Fiber Selection Criteria

Table 6-6 lists the criteria for selecting optical fibers. **Table 6-7** lists common optical connectors.

Table 6-6 Criteria for selecting optical fibers

Item	Criteria
Length	Survey result
Single-mode or multi-mode	<p>Optical transceiver type:</p> <ul style="list-style-type: none"> ● The multi-mode optical transmitting module is connected to the multi-mode fiber. ● The single-mode optical transmitting module is connected to the single-mode fiber. <p>NOTE If the optical fiber jumper is used, the connector connected to the device must be the LC/PC connector, and the connector connected to the remote end must be of the same type as the remote end port.</p>
Optical connector type	<ul style="list-style-type: none"> ● Square connector: SC/PC, LC/PC and MTRJ/PC ● Round connector: ST/PC and FC/PC

Table 6-7 Common optical connectors

 SC/PC connector	 LC/PC connector
 FC/PC connector	 MTRJ/PC connector
 ST/PC connector	-

6.4 Network Cable

Types of Network Cables

A network cable connects a maintenance terminal to the console port on the main control board for local or remote maintenance.

Network cables are classified into straight-through cables and crossover cables.

- A straight-through cable connects a terminal, such as a computer or switch, to the network. The straight-through cable uses two RJ45 connectors, which have the same pinout.
- A crossover cable connects two terminals, such as computers or switches. The crossover cable uses two RJ45 connectors, which have different pinouts.

Appearance and Structure

 **NOTE**

- Generally, a network cable is a standard unshielded network cable that uses RJ45 connectors.
- The appearances of the straight-through cable and the crossover cable are the same.

Figure 6-6 shows the appearance of a network cable.

Figure 6-6 Appearance of a network cable



Figure 6-7 shows the structure of a network cable.

Figure 6-7 Structure of a network cable

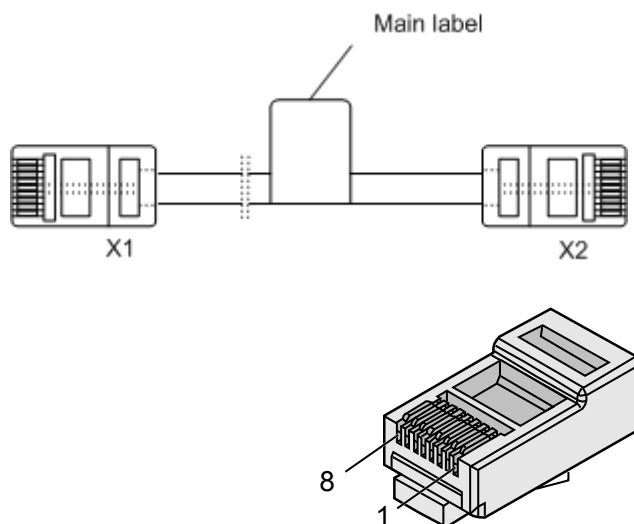

Pin Assignments

Table 6-8 shows the pin assignments of a straight-through cable.

Table 6-8 Pin assignments of a straight-through cable

X1 Pin	Wire Color	X2 Pin
1	White and orange	1
2	Orange	2
3	White and green	3
4	Blue	4
5	White and blue	5
6	Green	6
7	White and brown	7
8	Brown	8

Table 6-9 shows the pin assignments of a crossover cable.

Table 6-9 Pin assignments of a crossover cable

X1 Pin	Wire Color	X2 Pin
1	White and orange	3
2	Orange	6
3	White and green	1
4	Blue	4
5	White and blue	5
6	Green	2
7	White and brown	7
8	Brown	8

 **NOTE**

To achieve the best electrical transmission performance, ensure that the wires connected to pins 1 and 2 and to pins 3 and 6 are twisted pairs.

6.5 DC Power Cable

Types of DC Power Cables

DC power cables include a -48 V power return cable and a -48 V power cable. The -48 V power return cable connects to terminal marked with RTN (+), and the -48 V power cable connects to the terminal marked with NEG (-).

Appearance and Structure

Figure 6-8 and **Figure 6-9** show the appearance and structure of the 48 V power return cable and -48 V power cable.

Figure 6-8 Appearance of a -48 V power return cable



Figure 6-9 Appearance of a -48 V power cable



NOTE

A -48 V power return cable is black and is connected to the RTN(+) terminal of the DC power supply. A -48 V power cable is blue and is connected to the NEG(-) terminal of the DC power supply.

Connection

A DC power cable connects to the following:

- A DC power input port on the device
- Output power port on an external power system

6.6 AC Power Cable

Appearance and Structure

Figure 6-10 shows the appearance of an AC power cable.

Figure 6-10 AC power cable



 **NOTE**

The AC power cables used in different countries and regions may have different specifications. [Figure 6-10](#) shows the AC power cable complying with China's national standard. The power cable and plug in the package can only be used on the chassis in the package and cannot be used on other devices.

Connection

An AC power cable connects to the following:

- An AC power input port on the device
- Mains supply

6.7 RPS1800 Power Cable

Appearance and Structure

[Figure 6-11](#) shows the appearance of the RPS1800 AC power cable.

Figure 6-11 Appearance of the RPS1800 AC power cable



 **NOTE**

The PRS AC power cable used by the RPS1800 has the same appearance with a common AC power cable. However, the RPS AC power cable and common AC power cable connect to different connectors.

Connection

An RPS1800 AC power cable connects to the following:

- An AC power input port on the RPS1800 chassis
- Mains supply

6.8 RPS Cable

Appearance and Structure

[Figure 6-12](#) and [Figure 6-13](#) show the appearance and structure of an RPS cable.

Figure 6-12 Appearance of an RPS cable



Figure 6-13 Structure of an RPS cable

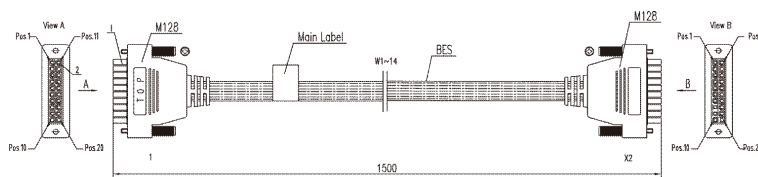

Connection

An RPS cable connects an RPS1800 power module to a switch so that the RPS1800 provides power to the switch. An RPS power cable connects to the following:

- A DC power output port on the RPS1800 chassis
- A switch to which power is provided

6.9 Console Cable

Appearance and Structure

Figure 6-15 and Figure 6-15 show the appearance and structure of a console cable.

Figure 6-14 Appearance of a console cable



Figure 6-15 Structure of a console cable

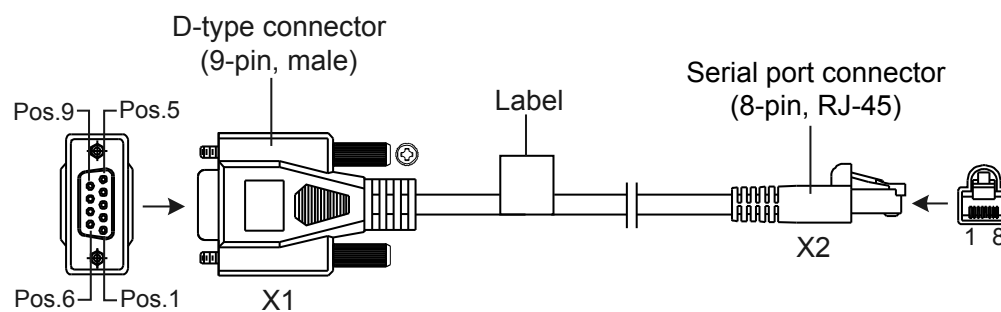

Pin Assignments

Table 6-10 describes the pin assignments of a console cable.

Table 6-10 Pin assignments of a console cable

Connector	X2 (RJ45)	Direction	X1 (DB9)	Signal
Pin assignment	1	--->	8	Clear to Send (CTS)
	2	--->	6	Data Set Ready (DSR)

Connector	X2 (RJ45)	Direction	X1 (DB9)	Signal
	3	--->	2	Receive Data (RXD)
	4	-	5	GND
	5	-	5	GND
	6	<---	3	Transmit Data (TXD)
	7	<---	4	Data Terminal Ready (DTR)
	8	<---	7	Request to Send (RTS)

Connection

A console cable connects the console port of the device to the serial port of an operation terminal to transmit configuration data. A shielded cable or an unshielded cable can be used according to the onsite situation.

A console cable connects the device and terminal as follows:

- The 8-pin RJ45 connector is inserted into the console port of the device.
- The DB9 connector is inserted into the terminal serial port.

7 Optical Module

About This Chapter

 **NOTE**

- In this document, optical modules are classified based on encapsulation types, and optical modules of each encapsulation type are classified based on interface rates.
- Appearances of optical modules in this document are only for reference, and appearances of actually delivered optical modules may differ.
- Use Huawei certified optical modules. Non-Huawei-certified optical modules cannot ensure transmission reliability and may affect service stability on the switch. Huawei is not responsible for any problem caused by non-Huawei-certified optical modules and will not fix such problems.

[7.1 Basic Concepts](#)

[7.2 SFP/eSFP Modules](#)

[7.3 SFP+ Modules](#)

7.1 Basic Concepts

Appearance and Structure

Figure 7-1 shows the appearance of an optical module.

Figure 7-1 Appearance of an optical module

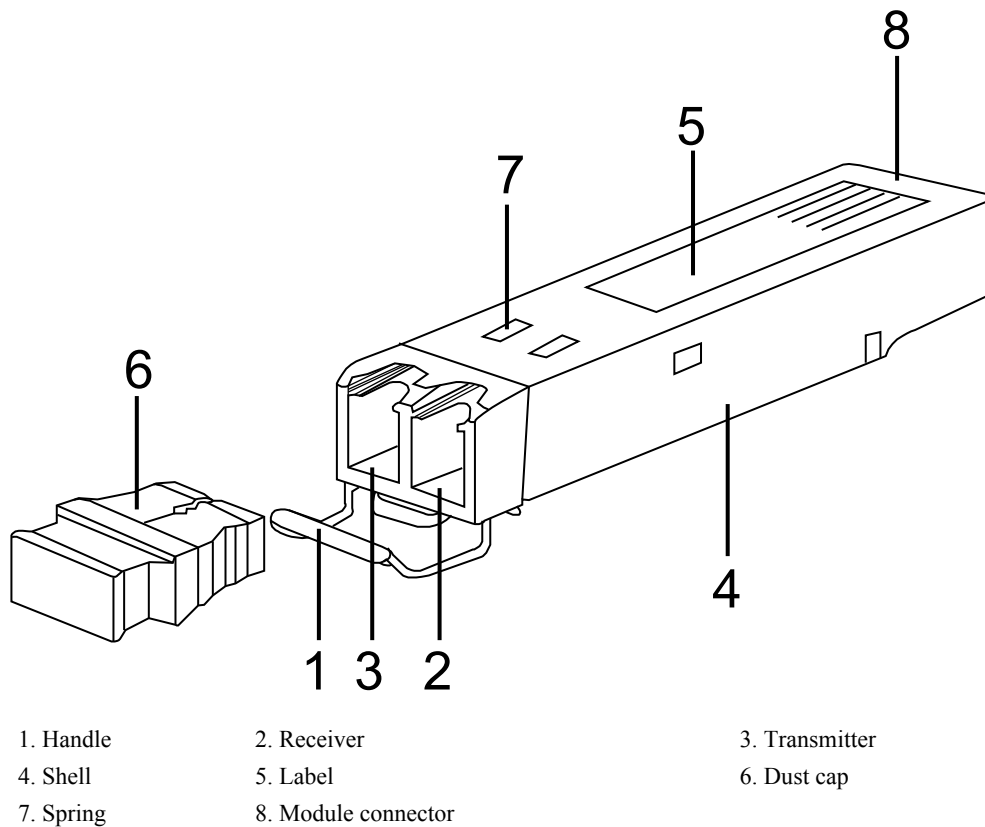

Terms

Encapsulation type Encapsulation type of an optical module. Encapsulation types of optical modules include SFP, eSFP, SFP+, as described in [Table 7-1](#).

Table 7-1 Encapsulation types of optical modules

Encapsulation Type	Description	Optical Module
SFP	Small form-factor pluggable.	FE optical module
eSFP	Enhanced small form-factor pluggable. An eSFP module is an SFP module that supports monitoring of voltage, temperature, bias current, transmit optical power, and receive optical power. Sometimes, eSFP is called SFP.	FE optical module (including the single-fiber bidirectional optical module)
		GE optical module (including the single-fiber bidirectional optical module)
		GE CWDM optical module
		GE DWDM optical module
		GE copper module
SFP+	Small form-factor pluggable plus, SFP with a higher rate. SFP+ modules are more sensitive to electromagnetic interference (EMI) because they have a higher rate. To reduce EMI, SFP+ modules have more springs than SFP modules and the cages for SFP+ modules on a card are tighter.	10GE optical module

Transmission distance Maximum distance over which optical signals can transmit. Optical signals sent from different types of sources can transmit over different distances due to negative effects of optical fibers, such as dispersion and attenuation.

Interface rate Maximum rate of electrical signals that an optical device can transmit without bit errors. The interface rates defined in Ethernet standards include 125 Mbit/s, 1.25 Gbit/s, 10.3125 Gbit/s, and 41.25 Gbit/s.

Center wavelength Wavelength measured at the midpoint of the half-amplitude line in the transmit spectrum.

Fiber mode	Mode of fibers defining based on core diameters and features of optical fibers. Optical fibers are classified into single-mode fibers and multimode fibers. Generally, multimode fibers have large core diameters and severe dispersion, so they transmit optical signals over short distances when working with multimode optical modules. Single-mode fibers have small dispersion and can transmit optical signals over long distances when working with single-mode optical modules.
Pattern bandwidth	Bandwidth measured at a point with transmit power several dB lower than that of the point with the peak center wavelength. Pattern bandwidth reflects spectrum characteristics of an optical module.
Fiber diameter	Diameter of the core of a fiber. According to international standards for optical fibers, the diameter of a multimode fiber is 62.5 um or 50 um, and the diameter of a single-mode fiber is 9 um.
Fiber class	Optical signals with different wavelengths have their best working windows in different optical fibers. To help efficiently adjust wavelengths or dispersion features of optical fibers and change their refractive indexes, the following classes are defined: multimode fiber (G.651), common single-mode fiber (G.652), shifted dispersion fiber (G.653), and non-zero shifted dispersion fiber (G.655). G.651 and G.652 are commonly used fiber classes.
Connector type	Type of the interface on an optical module to accommodate a fiber. Commonly used connector types are LC (applicable to all the SFP, SFP+, and XFP modules), SC, and MPO (applicable to 150 m QSFP+ and CXP modules).
Transmit optical power	Output optical power of an optical module when it is working properly.
Maximum receiver sensitivity	Minimum average input optical power that the receiver of an optical module can receive within a range of bit error rate (BER = 10 to 12).
Overload optical power	Maximum average input optical power that the receiver of an optical module can receive within a range of bit error rate (BER = 10 to 12).
Extinction ratio	Minimum ratio of the average optical power with signals transmitted against the average optical power without signals transmitted in complete modulation mode. The extinction ratio indicates the capability of an optical module to identify signal 0 and signal 1.

7.2 SFP/eSFP Modules

Appearance

[Figure 7-2](#) shows the appearance of an SFP/eSFP optical module.

Figure 7-2 Appearance of an SFP/eSFP optical module

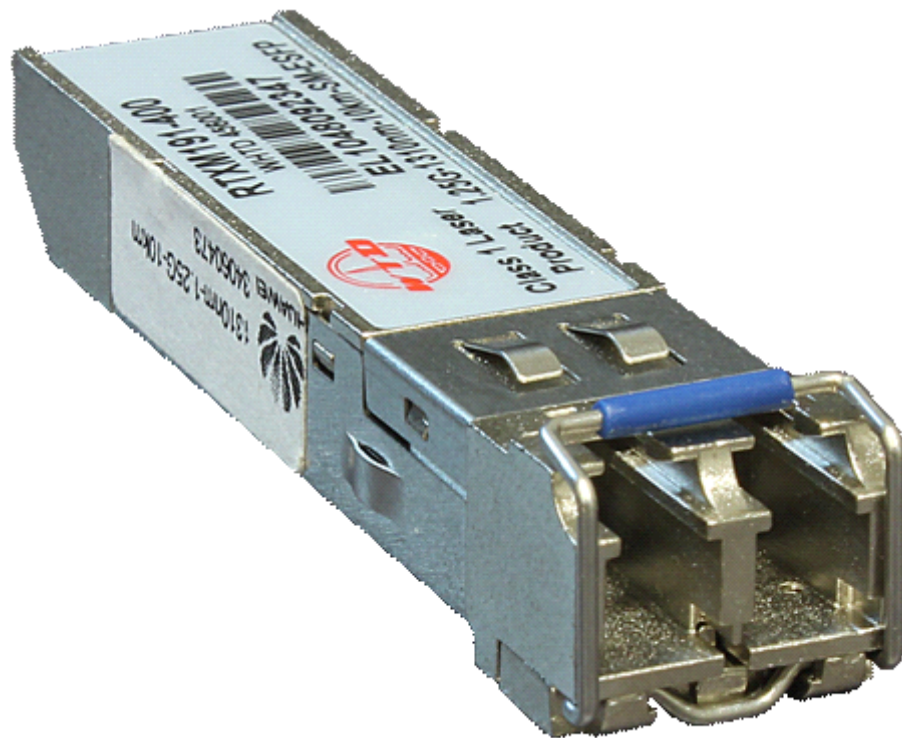

FE Optical Module

[Table 7-2](#) and [Table 7-3](#) list the attributes of an FE optical module.

Table 7-2 Attributes of FE optical modules

Model	Transmission Distance (km)	Standard	Fiber Type
SFP-FE-SX-MM1310 (SFP optical module)	≤ 2	100base-FX	<ul style="list-style-type: none"> Fiber mode: multimode Core diameter: 50/125 μm or 62.5/125 μm Connector type: LC
eSFP-FE-LX-SM1310	≤ 15	100base-LX	<ul style="list-style-type: none"> Fiber mode: single-mode Connector type: LC
S-SFP-FE-LH40-SM1310	≤ 40		
S-SFP-FE-LH80-SM1550	≤ 80		
SFP-FE-LX-SM1310-BIDI (Bidirectional optical module)	≤ 15	100base-BX	
SFP-FE-LX-SM1550-BIDI (Bidirectional optical module)			

Table 7-3 Optical parameters of FE optical modules

Model	Center Wavelength (nm)	Transmit Power (dBm)	Receiver Sensitivity (dBm)	Overload Optical Power (dBm)	Extinction Ratio (dB)	Supported Switch
SFP-FE-SX-MM1310 (SFP optical module)	1310	-19.0 to -14.0	≤ -30.0	-14.0	10	<ul style="list-style-type: none"> S5700-LI (only the combo ports) S5700-SI (only the combo ports of the S5700-SI and 12 GE optical ports on the S5700-26X-SI-12S-AC) S5710-EI (only the combo ports) S5700-28C-HI-24S (only the 24 GE optical ports) S5700-28C-EI-24S (only the 20 GE optical ports and 4 combo ports)
eSFP-FE-LX-SM1310	1310	-15.0 to -8.0	≤ -31.0	-8.0	8.2	
S-SFP-FE-LH40-SM1310	1310	-5.0 to 0	≤ -37.0	-10.0	10.5	
S-SFP-FE-LH80-SM1550	1550					

Model	Center Wavelength (nm)	Transmit Power (dBm)	Receiver Sensitivity (dBm)	Overload Optical Power (dBm)	Extinction Ratio (dB)	Supported Switch
SFP-FE-LX-SM1310-BIDI (Bidirectional optical module)	RX1550/ TX1310	-15.0 to -8.0	≤ -32.0	-8.0	8.5	
SFP-FE-LX-SM1550-BIDI (Bidirectional optical module)	TX1550/ RX1310					

GE Optical Module

[Table 7-4](#) and [Table 7-5](#) list the attributes of a GE optical module.

Table 7-4 Attributes of GE optical modules

Model	Transmission Distance (km)	Standard	Fiber Type
eSFP-GE-SX-MM850	≤ 0.22	1000base-SX	<ul style="list-style-type: none"> ● Fiber mode: multimode ● Pattern bandwidth: 160 MHz*km ● Core diameter: 62.5 μm ● Connector type: LC
	≤ 0.275		<ul style="list-style-type: none"> ● Fiber mode: multimode (OM1) ● Connector type: LC
	≤ 0.5		<ul style="list-style-type: none"> ● Fiber mode: multimode ● Pattern bandwidth: 400 MHz*km ● Core diameter: 50 μm ● Connector type: LC
	≤ 0.55		<ul style="list-style-type: none"> ● Fiber mode: multimode (OM2) ● Connector type: LC
	≤ 1		<ul style="list-style-type: none"> ● Fiber mode: multimode (OM3) ● Connector type: LC

Model	Transmission Distance (km)	Standard	Fiber Type
SFP-GE-LX-SM1310	≤ 10	1000base-LX/LH	<ul style="list-style-type: none"> ● Fiber mode: single-mode ● Connector type: LC
S-SFP-GE-LH40-SM1310	≤ 40	1000base-LX/LH	
S-SFP-GE-LH40-SM1550		1000base-LX/LH	
S-SFP-GE-LH80-SM1550	≤ 80	1000base-ZX	
eSFP-GE-ZX100-SM1550	≤ 100	1000base-ZX	
SFP-GE-LX-SM1310-BIDI (Bidirectional optical module)	≤ 10	1000base-BX	
SFP-GE-LX-SM1490-BIDI (Bidirectional optical module)		1000base-BX	
LE2MGSC40DE0 (Bidirectional optical module)	≤ 40	1000base-BX	
LE2MGSC40ED0 (Bidirectional optical module)		1000base-BX	

Table 7-5 Optical parameters of GE optical modules

Model	Center Wavelength (nm)	Transmit Power (dBm)	Receiver Sensitivity (dBm)	Overload Optical Power (dBm)	Extinction Ratio (dB)	Supported Switch
eSFP-GE-SX-MM850	850	-9.5 to -2.5	≤ -17.0	0	9	<ul style="list-style-type: none"> ● S5700-LI (all optical ports) ● S5700S-LI (all optical ports) ● S5700-SI (all optical ports)

Model	Center Wavelength (nm)	Transmit Power (dBm)	Receiver Sensitivity (dBm)	Overload Optical Power (dBm)	Extinction Ratio (dB)	Supported Switch
SFP-GE-LX-SM1310	1310	-9.0 to -3.0	\leq -20.0	-3.0	9	<ul style="list-style-type: none"> ● S5700-EI (all optical ports except those on 10GE cards) ● S5700-HI (all optical ports) ● S5710-EI (all optical ports) NOTE Ports on the S5700-10P-PWR-LI-AC do not support 80 km and 100 km optical modules.
S-SFP-GE-LH40-SM1310	1310	-5.0 to 0	\leq -23	-3.0	9	
S-SFP-GE-LH40-SM1550	1550	-5.0 to 0	\leq -22	-3.0	8.5	
S-SFP-GE-LH80-SM1550	1550	-2.0 to 5.0	\leq -23.0	-3.0	9	
eSFP-GE-ZX100-SM1550	1550	0 to 5	\leq -30.0	-9.0	9	
SFP-GE-LX-SM1310-BIDI (Bidirectional optical module)	RX14 90/ TX13 10	-9.0 to -3.0	\leq -19.5	-3.0	6	
SFP-GE-LX-SM1490-BIDI (Bidirectional optical module)	RX13 10/ TX14 90	-9.0 to -3.0	\leq -19.5	-3.0	6	
LE2MGSC40 DE0 (Bidirectional optical module)	RX14 90/ TX13 10	-2.0 to 3.0	\leq -23	-3.0	9	
LE2MGSC40E D0 (Bidirectional optical module)	RX13 10/ TX14 90	-2.0 to 3.0	\leq -23	-3.0	9	

GE-CWDM Optical Module

Table 7-6 lists the attributes of a GE coarse wavelength division multiplexing (CWDM) optical module.

Table 7-6 Attributes of CWDM optical modules

Center Wavelength (nm), Model	1471, CWDM-SFPGE-1471	1491, CWDM-SFPGE-1491	1511, CWDM-SFPGE-1511	1531, CWDM-SFPGE-1531
	1551, CWDM-SFPGE-1551	1571, CWDM-SFPGE-1571	1591, CWDM-SFPGE-1591	1611, CWDM-SFPGE-1611
Specifications	Encapsulation type: eSFP			
	Transmission distance: ≤ 80 km			
	Fiber type: single-mode, LC			
	Standard: CWDM			
	Operating temperature: 0°C to 70°C			
	<ul style="list-style-type: none"> ● Transmit power: 0 dBm to 5.0 dBm ● Receiver sensitivity: ≤ -28.0 dBm ● Overload optical power: -9.0 dBm ● Extinction ratio: 8.5 dB 			
Supported Switch	<ul style="list-style-type: none"> ● S5700-LI (all optical ports) ● S5700S-LI (all optical ports) ● S5700-SI (all optical ports) ● S5700-EI (all optical ports except those on 10GE cards) ● S5700-HI (all optical ports) ● S5710-EI (all optical ports) 			
	<p>NOTE The S5700-10P-PWR-LI-AC does not support CWDM optical modules.</p>			

 **NOTE**

The appearance of CWDM and DWDM optical modules is similar to that of common optical modules. These optical modules are distinguished by their labels. In practice, the corresponding optical fibers are labeled to distinguish the optical modules.

GE-DWDM Optical Module

Table 7-7 lists the attributes of a GE dense wavelength division multiplexing (DWDM) optical module.

Table 7-7 Attributes of DWDM optical modules

Center Wavelength (nm), Model	1529.55, DWDM-SFPGE-1529-55	1530.33, DWDM-SFPGE-1530-33	1531.12, DWDM-SFPGE-1531-12	1531.90, DWDM-SFPGE-1531-90	1532.68, DWDM-SFPGE-1532-68
--------------------------------------	-----------------------------	-----------------------------	-----------------------------	-----------------------------	-----------------------------

	1533.47, DWDM- SFPGE-1533- 47	1534.25, DWDM- SFPGE-1534- 25	1535.04, DWDM- SFPGE-1535- 04	1535.82, DWDM- SFPGE-153 5-82	1536.61, DWDM- SFPGE-1536- 61
	1537.40, DWDM- SFPGE-1537- 40	1538.19, DWDM- SFPGE-1538- 19	1538.98, DWDM- SFPGE-1538- 98	1539.77, DWDM- SFPGE-153 9-77	1540.56, DWDM- SFPGE-1540- 56
	1541.35, DWDM- SFPGE-1541- 35	1542.14, DWDM- SFPGE-1542- 14	1542.94, DWDM- SFPGE-1542- 94	1543.73, DWDM- SFPGE-154 3-73	1544.53, DWDM- SFPGE-1544- 53
	1545.32, DWDM- SFPGE-1545- 32	1546.12, DWDM- SFPGE-1546- 12	1546.92, DWDM- SFPGE-1546- 92	1547.72, DWDM- SFPGE-154 7-72	1548.51, DWDM- SFPGE-1548- 51
	1549.32, DWDM- SFPGE-1549- 32	1550.12, DWDM- SFPGE-1550- 12	1550.92, DWDM- SFPGE-1550- 92	1551.72, DWDM- SFPGE-155 1-72	1552.52, DWDM- SFPGE-1552- 52
	1553.33, DWDM- SFPGE-1553- 33	1554.13, DWDM- SFPGE-1554- 13	1554.94, DWDM- SFPGE-1554- 94	1555.75, DWDM- SFPGE-155 5-75	1556.55, DWDM- SFPGE-1556- 55
	1557.36, DWDM- SFPGE-1557- 36	1558.17, DWDM- SFPGE-1558- 17	1558.98, DWDM- SFPGE-1558- 98	1559.79, DWDM- SFPGE-155 9-79	1560.61, DWDM- SFPGE-1560- 61
Specifi cations	Encapsulation type: eSFP				
	Transmission distance: ≤ 120 km				
	Fiber type: single-mode, LC				
	Standard: DWDM				
	Operating temperature: 0°C to 70°C				
	<ul style="list-style-type: none"> ● Transmit power: 0 dBm to 4.0 dBm ● Receiver sensitivity: ≤ -28.0 dBm ● Overload optical power: -8.0 dBm ● Extinction ratio: 8.2 dB 				

Supported Switch	<ul style="list-style-type: none"> ● S5700-LI (all optical ports) ● S5700S-LI (all optical ports) ● S5700-SI (GE cards and 10GE SFP+ cards of the S5700-SI, and optical ports on the S5700-26X-SI-12S-AC) ● S5700-EI (only GE cards) ● S5700-HI (only GE and 10GE SFP+ cards) ● S5710-EI (all optical ports) <p>NOTE The S5700-10P-PWR-LI-AC does not support DWDM optical modules.</p>
-------------------------	--

GE SFP Copper Module

Table 7-8 lists the attributes of a GE SFP copper module.

Table 7-8 Attributes of a GE SFP copper module

Model	Transmission Distance (km)	Connector Type	Standard	Supported Switch
SFP-1000 BaseT	0.1	RJ45	1000Base-T	<ul style="list-style-type: none"> ● S5700-LI (all optical ports except combo ports) ● S5700S-LI (all optical ports) ● S5700-SI (all optical ports except combo ports) ● S5700-EI (all optical ports except those on 10GE cards and combo ports) ● S5700-HI (all optical ports) ● S5710-EI (all optical ports except those on GE cards and combo ports)

7.3 SFP+ Modules

Appearance

Figure 7-3 shows the appearance of an SFP+ optical module.

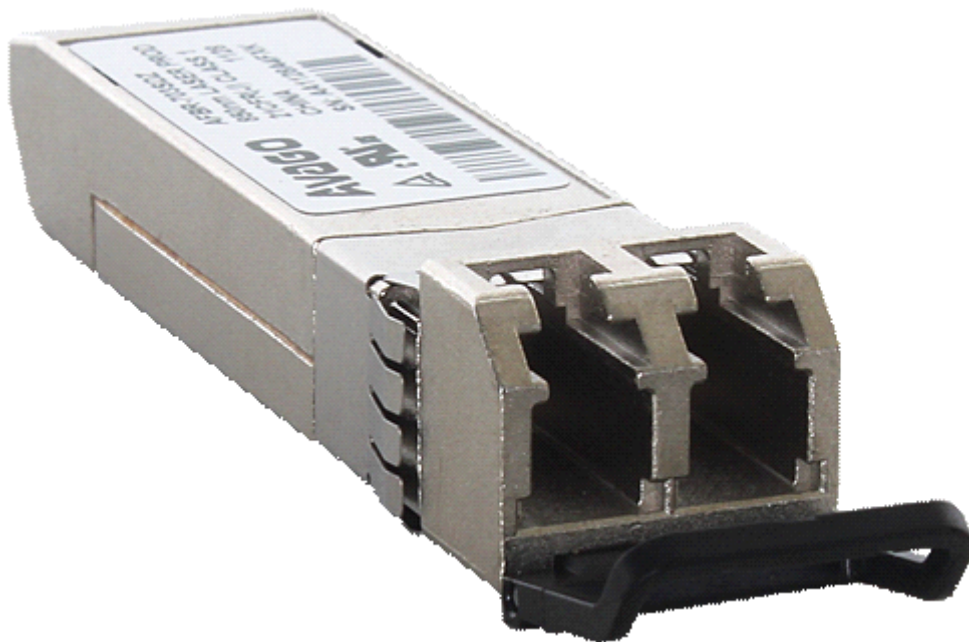
Figure 7-3 Appearance of an SFP+ optical module

10GE SFP+ Optical Module

Table 7-9 and **Table 7-10** list the attributes of a 10GE SFP+ optical module.

Table 7-9 Attributes of 10GE SFP+ optical modules

Model	Transmission Distance (km)	Standard	Fiber Type
OSXD22N00	≤ 0.1	10Gbase-LRM	<ul style="list-style-type: none"> Fiber mode: multimode Pattern bandwidth: 400 MHz*km Core diameter: 50 μm Connector type: LC
	≤ 0.22		<ul style="list-style-type: none"> Fiber mode: multimode Pattern bandwidth: 500 MHz*km Core diameter: 62.5 μm Connector type: LC
			<ul style="list-style-type: none"> Fiber mode: multimode (OM1, OM2, OM3) Connector type: LC
OMXD30000	≤ 0.026	10Gbase-SR	<ul style="list-style-type: none"> Fiber mode: multimode Pattern bandwidth: 160 MHz*km Core diameter: 62.5 μm Connector type: LC

Model	Transmission Distance (km)	Standard	Fiber Type
	≤ 0.033		<ul style="list-style-type: none"> Fiber mode: multimode (OM1) Connector type: LC
	≤ 0.066		<ul style="list-style-type: none"> Fiber mode: multimode Pattern bandwidth: 400 MHz*km Core diameter: 50 μm Connector type: LC
	≤ 0.082		<ul style="list-style-type: none"> Fiber mode: multimode (OM2) Connector type: LC
	≤ 0.3		<ul style="list-style-type: none"> Fiber mode: multimode (OM3) Connector type: LC
	≤ 0.4		<ul style="list-style-type: none"> Fiber mode: multimode (OM4) Connector type: LC
OSX010000	≤ 10	10Gbase-LR	<ul style="list-style-type: none"> Fiber mode: single-mode Connector type: LC
OSX040N01	≤ 40	10Gbase-ER	<ul style="list-style-type: none"> Connector type: LC
LE2MXSC80 FF0 linear	≤ 80	10Gbase-ZR	<ul style="list-style-type: none"> Fiber mode: single-mode Connector type: LC

Table 7-10 Optical parameters of 10GE SFP+ optical modules

Model	Center Wavelength (nm)	Transmit Power (dBm)	Receiver Sensitivity (dBm)	Overload Optical Power (dBm)	Extinction Ratio (dB)	Supported Switch
OSXD22N00	1310	-6.5 to 0.5	≤ -6.5	1.5	3.5	<ul style="list-style-type: none"> S5700-LI (10GE optical ports on the switch) S5700-SI (10GE optical ports and 10GE SFP+ cards on the switch) S5700-EI (10GE SFP+ cards) S5700-HI (10GE SFP+ cards)
OMXD30000	850	-7.3 to -1.0	≤ -11.1	-1.0	3.0	
OSX010000	1310	-8.2 to 0.5	≤ -12.6	0.5	3.5	

Model	Center Wavelength (nm)	Transmit Power (dBm)	Receiver Sensitivity (dBm)	Overload Optical Power (dBm)	Extinction Ratio (dB)	Supported Switch
OSX040N01	1550	-4.7 to 4.0	\leq -14.1	-1.0	3	<ul style="list-style-type: none">● S5710-EI (10GE optical ports and 10GE SFP+ cards on the switch)
LE2MXSC8 OFF0 linear	1550	0 to 4.0	\leq -24.0	-7.0	9	<ul style="list-style-type: none">● S5700-LI (10GE optical ports on the switch)● S5700-26X-SI-12S-AC (10GE optical ports on the switch)● S5710-EI (10GE optical ports and 10GE SFP+ cards on the switch)