



S7700 Smart Routing Switch

V200R001C00

Hardware Description

Issue 06

Date 2013-03-05

Copyright © Huawei Technologies Co., Ltd. 2013. All rights reserved.

No part of this document may be reproduced or transmitted in any form or by any means without prior written consent of Huawei Technologies Co., Ltd.

Trademarks and Permissions



HUAWEI and other Huawei trademarks are trademarks of Huawei Technologies Co., Ltd.

All other trademarks and trade names mentioned in this document are the property of their respective holders.

Notice

The purchased products, services and features are stipulated by the contract made between Huawei and the customer. All or part of the products, services and features described in this document may not be within the purchase scope or the usage scope. Unless otherwise specified in the contract, all statements, information, and recommendations in this document are provided "AS IS" without warranties, guarantees or representations of any kind, either express or implied.

The information in this document is subject to change without notice. Every effort has been made in the preparation of this document to ensure accuracy of the contents, but all statements, information, and recommendations in this document do not constitute a warranty of any kind, express or implied.

Huawei Technologies Co., Ltd.

Address: Huawei Industrial Base
Bantian, Longgang
Shenzhen 518129
People's Republic of China

Website: <http://enterprise.huawei.com>

About This Document

Intended Audience

This document provides an overall description of the S7700, details about each chassis and board, cables available to the device, and lists of components.





This document describes hardware features of the S7700, which helps intended readers obtain detailed information about each chassis, board, and cable, and rapidly locate specific information through lists of components.

This document is intended for:

- Network planning engineers
- Hardware installation engineers
- Commissioning engineers
- On-site maintenance engineers
- System maintenance engineers

Symbol Conventions

The symbols that may be found in this document are defined as follows.

Symbol	Description
 DANGER	Indicates a hazard with a high level or medium level of risk which, if not avoided, could result in death or serious injury.
 WARNING	Indicates a hazard with a low level of risk which, if not avoided, could result in minor or moderate injury.
 CAUTION	Indicates a potentially hazardous situation that, if not avoided, could result in equipment damage, data loss, performance deterioration, or unanticipated results.
 TIP	Provides a tip that may help you solve a problem or save time.
 NOTE	Provides additional information to emphasize or supplement important points in the main text.

Command Conventions

The command conventions that may be found in this document are defined as follows.

Convention	Description
Boldface	The keywords of a command line are in boldface .
<i>Italic</i>	Command arguments are in <i>italics</i> .
[]	Items (keywords or arguments) in brackets [] are optional.
{ x y ... }	Optional items are grouped in braces and separated by vertical bars. One item is selected.
[x y ...]	Optional items are grouped in brackets and separated by vertical bars. One item is selected or no item is selected.
{ x y ... }*	Optional items are grouped in braces and separated by vertical bars. A minimum of one item or a maximum of all items can be selected.
[x y ...]*	Optional items are grouped in brackets and separated by vertical bars. Several items or no item can be selected.
&<1-n>	The parameter before the & sign can be repeated 1 to n times.
#	A line starting with the # sign is comments.

Change History

Updates between document issues are cumulative. Therefore, the latest document issue contains all updates made in previous issues.

Changes in Issue 06 (2013-03-05)

Based on issue 05 (2012-12-12), this issue has the following updates:

The following sections are modified:

- [2.3 System Configuration and Physical Specifications](#)

Changes in Issue 05 (2012-12-12)

Based on issue 04 (2012-10-20), this issue has the following updates:

The following sections are modified:

- [2.3 System Configuration and Physical Specifications](#)

Changes in Issue 04 (2012-10-20)

Based on issue 03 (2012-09-03), this issue has the following updates:

The following sections are modified:

- **5.1.1 Board Classification**
- **2.3 System Configuration and Physical Specifications**

Changes in Issue 03 (2012-09-03)

Based on issue 02 (2012-05-23), this issue has the following updates:

The following sections are modified:

- **3.1.1 Configuration and Operation Modes of Power Supplies**
- **2.3 System Configuration and Physical Specifications**

Changes in Issue 02 (2012-05-23)

Based on issue 01 (2012-03-15), this issue has the following updates:

The following sections are modified:

- **5.13 X40SFC-40-Port 10GE Optical Interface Card (FC, SFP+)**

Changes in Issue 01 (2012-03-15)

Initial commercial release.

Contents

About This Document.....	ii
1 Cabinets.....	1
1.1 Introduction to the N66E Cabinet.....	2
1.1.1 Appearance of the N66E Cabinet.....	2
1.1.2 Technical Specifications of the N66E Cabinet.....	2
1.1.3 Components of the N66E Cabinet.....	3
1.1.4 Operating Environment of the N66E Cabinet.....	4
1.1.5 Structural Features of the N66E Cabinet.....	5
1.2 Introduction to the N68E Cabinet.....	8
1.2.1 Appearance of the N68E cabinet	8
1.2.2 Technical Specifications of the N68E cabinet.....	9
1.2.3 Components of the N68E cabinet.....	10
1.2.4 Operating Environment of the N68E cabinet.....	10
1.2.5 Structural Features of the N68E cabinet.....	11
2 Chassis.....	15
2.1 Introduction.....	16
2.2 Hardware Structure.....	16
2.2.1 S7712.....	16
2.2.2 S7706.....	20
2.2.3 S7703.....	23
2.3 System Configuration and Physical Specifications.....	25
2.3.1 System Configuration.....	25
2.3.2 Physical Specifications.....	27
3 Power Supply.....	30
3.1 Introduction.....	31
3.1.1 Configuration and Operation Modes of Power Supplies.....	31
3.1.2 Power Supply Principle.....	37
3.2 1600 W DC Power Supply.....	38
3.2.1 Function Overview.....	38
3.2.2 Appearance and Panel.....	38
3.2.3 Technical Specifications.....	40
3.3 800 W AC Power Supply.....	41

3.3.1 Function Overview.....	41
3.3.2 Appearance and Panel.....	41
3.3.3 Technical Specifications.....	43
3.4 2200 W AC Power Supply.....	43
3.4.1 Function Overview.....	43
3.4.2 Appearance and Panel.....	44
3.4.3 Technical Specifications.....	45
4 Heat Dissipation System.....	46
4.1 Introduction.....	47
4.1.1 Heat Dissipation System of the S7712.....	47
4.1.2 Heat Dissipation System of the S7706.....	47
4.1.3 Heat Dissipation System of the S7703.....	48
4.2 Fan Module.....	48
4.2.1 Function Overview.....	48
4.2.2 Panel.....	50
4.2.3 Technical Specifications of the Fan Modules on the S7700.....	51
4.3 Air Filter.....	52
4.3.1 Air Filter of the S7712.....	52
4.3.2 Air Filter of the S7706.....	52
4.3.3 Air Filter of the S7703.....	53
5 Boards.....	54
5.1 Introduction.....	57
5.1.1 Board Classification.....	57
5.1.2 Slot Distribution and Board Dimensions.....	58
5.1.3 Relation Between Boards.....	61
5.1.4 Interfaces on the Boards.....	63
5.2 SRU-Main Control Unit.....	65
5.2.1 Introduction.....	65
5.2.2 Function and Application.....	65
5.2.3 Panel.....	66
5.2.4 Interfaces.....	68
5.2.5 Interface Attributes.....	68
5.2.6 Technical Specifications.....	69
5.3 MCUA-Main Control Unit.....	70
5.3.1 Introduction.....	70
5.3.2 Function and Application.....	70
5.3.3 Panel.....	71
5.3.4 Interfaces.....	72
5.3.5 Interface Attributes.....	73
5.3.6 Technical Specifications.....	74
5.4 FSUA - Enhanced Flexible Service Unit.....	74
5.4.1 Introduction.....	74

5.4.2 Function and Application.....	75
5.4.3 Panel.....	75
5.4.4 Technical Specifications.....	76
5.5 VSTSA - Stacking Card on the Main Control Board.....	76
5.5.1 Introduction.....	76
5.5.2 Function and Application.....	77
5.5.3 Panel.....	77
5.5.4 Interfaces.....	78
5.5.5 Technical Specifications.....	79
5.6 CMU - Centralized Monitoring Unit.....	79
5.6.1 Introduction.....	79
5.6.2 Function and Application.....	80
5.6.3 Panel.....	80
5.6.4 Interfaces.....	81
5.6.5 Interface Attributes.....	81
5.6.6 Technical Specifications.....	82
5.7 SPU - VAMPA VAS Board.....	82
5.7.1 Introduction.....	83
5.7.2 Function and Application.....	83
5.7.3 Panel.....	83
5.7.4 Interfaces.....	84
5.7.5 Interface Attributes.....	84
5.7.6 Technical Specifications.....	85
5.8 G48S - 48-Port 100/1000BASE-X Interface Card (SFP).....	85
5.8.1 Introduction.....	85
5.8.2 Function and Application.....	86
5.8.3 Panel.....	86
5.8.4 Interfaces.....	87
5.8.5 Interface Attributes.....	87
5.8.6 Technical Specifications.....	91
5.9 G48T - 48-Port 10/100/1000BASE-T Interface Card (RJ45).....	91
5.9.1 Introduction.....	91
5.9.2 Function and Application.....	92
5.9.3 Panel.....	92
5.9.4 Interfaces.....	93
5.9.5 Interface Attributes.....	93
5.9.6 Technical Specifications.....	94
5.10 G48VA - 48-Port 10/100/1000BASE-T PoE Interface Card(EA,RJ45,PoE).....	94
5.10.1 Introduction.....	94
5.10.2 Function and Application.....	95
5.10.3 Panel.....	95
5.10.4 Interfaces.....	96

5.10.5 Interface Attributes.....	96
5.10.6 Technical Specifications.....	97
5.11 G48CEAT - 36-Port 10/100/1000BASE-T and 12-Port 100/1000BASE-X Interface Card(EA, RJ45/SFP)	97
5.11.1 Introduction.....	97
5.11.2 Function and Application.....	98
5.11.3 Panel.....	98
5.11.4 Interfaces.....	99
5.11.5 Interface Attributes.....	99
5.11.6 Technical Specifications.....	102
5.12 F48T - 48-Port 10/100BASE-T Interface Card (RJ45).....	103
5.12.1 Introduction.....	103
5.12.2 Function and Application.....	103
5.12.3 Panel.....	103
5.12.4 Interfaces.....	104
5.12.5 Interface Attributes.....	105
5.12.6 Technical Specifications.....	105
5.13 X40SFC-40-Port 10GE Optical Interface Card (FC, SFP+).....	106
5.13.1 Introduction.....	106
5.13.2 Function and Application.....	106
5.13.3 Panel.....	106
5.13.4 Interfaces.....	107
5.13.5 Interface Attributes.....	107
5.13.6 Technical Specifications.....	109
5.14 X16SFC-16-Port 10GE Optical Interface Card (FC, SFP+).....	110
5.14.1 Introduction.....	110
5.14.2 Function and Application.....	110
5.14.3 Panel.....	110
5.14.4 Interfaces.....	111
5.14.5 Interface Attributes.....	112
5.14.6 Technical Specifications.....	114
5.15 G24CA - 24-Port 100/1000BASE-X and 8-Port 10/100/1000BASE-T Interface Card (SFP/RJ45).....	114
5.15.1 Introduction.....	114
5.15.2 Function and Application.....	115
5.15.3 Panel.....	115
5.15.4 Interfaces.....	116
5.15.5 Interface Attributes.....	117
5.15.6 Technical Specifications.....	120
5.16 S24XA-24-Port 100M/1000M Ethernet Optical Interface + 2-Port 10GE Optical Interface Line Card (EA, SFP/XFP).....	120
5.16.1 Introduction.....	121
5.16.2 Function and Application.....	121
5.16.3 Panel.....	121

5.16.4 Interfaces.....	122
5.16.5 Interface Attributes.....	122
5.16.6 Technical Specifications.....	128
5.17 T24XA - 24-Port 10/100/1000BASE-T and 2-Port 10GBASE-X Interface Card(EA,RJ45/XFP).....	128
5.17.1 Introduction.....	128
5.17.2 Function and Application.....	128
5.17.3 Panel.....	129
5.17.4 Interfaces.....	130
5.17.5 Interface Attributes.....	130
5.17.6 Technical Specifications.....	132
5.18 G24S - 24-Port 100/1000BASE-X Interface Card (SFP).....	133
5.18.1 Introduction.....	133
5.18.2 Function and Application.....	133
5.18.3 Panel.....	134
5.18.4 Interfaces.....	135
5.18.5 Interface Attributes.....	135
5.18.6 Technical Specifications.....	138
5.19 G24TFA-24-Port 10/100/1000BASE-T Interface Card(FA,RJ45).....	138
5.19.1 Introduction.....	138
5.19.2 Function and Application.....	138
5.19.3 Panel.....	139
5.19.4 Interfaces.....	140
5.19.5 Interface Attributes.....	140
5.19.6 Technical Specifications.....	140
5.20 X12SA - 12-Port 10GE Optical Interface Card (SA, SFP+).....	141
5.20.1 Introduction.....	141
5.20.2 Function and Application.....	141
5.20.3 Panel.....	141
5.20.4 Interfaces.....	142
5.20.5 Interface Attributes.....	143
5.20.6 Technical Specifications.....	144
5.21 X4UX - 4-Port 10GBASE-X Interface Card (XFP).....	144
5.21.1 Introduction.....	144
5.21.2 Function and Application.....	145
5.21.3 Panel.....	145
5.21.4 Interfaces.....	146
5.21.5 Interface Attributes.....	146
5.21.6 Technical Specifications.....	148
5.22 X2UX - 2-Port 10GBASE-X Interface Card (XFP).....	149
5.22.1 Introduction.....	149
5.22.2 Function and Application.....	149
5.22.3 Panel.....	149

5.22.4 Interfaces.....	150
5.22.5 Interface Attributes.....	151
5.22.6 Technical Specifications.....	153
6 Cables.....	154
6.1 DC Power Cable.....	155
6.1.1 Introduction.....	155
6.1.2 Structure.....	155
6.1.3 Technical Specifications.....	155
6.2 AC Power Cable.....	157
6.2.1 Introduction.....	157
6.2.2 Structure.....	158
6.2.3 Technical Specifications.....	158
6.3 Ground Cable.....	159
6.3.1 Introduction.....	159
6.3.2 Structure.....	159
6.3.3 Technical Specifications of the Ground Cables.....	160
6.4 Console Cable.....	160
6.4.1 Introduction.....	160
6.4.2 Structure.....	160
6.4.3 Technical Specifications.....	161
6.5 Ethernet Cable.....	162
6.5.1 Introduction.....	162
6.5.2 Structure.....	162
6.5.3 Technical Specifications.....	164
6.6 Optical Fiber.....	164
6.6.1 Introduction.....	165
6.6.2 Optical Connector.....	166
6.6.3 Technical Specifications.....	166
6.7 Clock Cable.....	167
6.7.1 Introduction.....	167
6.7.2 Structure.....	168
6.7.3 Technical Specifications.....	169
6.8 Stack Cables.....	171
6.8.1 Introduction.....	171
6.8.2 Structure.....	171
6.8.3 Technical Specifications.....	171
7 List of Indicators.....	173
7.1 Fan Module Indicators.....	174
7.2 Power Supply Indicators.....	174
7.3 SRU Indicators.....	175
7.4 MCUA Indicators.....	176
7.5 LPU Indicators.....	177

7.6 CMU Indicators.....	178
8 List of Boards.....	180
8.1 Boards Supported by the S7700.....	181
8.2 Power Consumption and Weight.....	183
9 Attribute List of Interfaces and Its Pluggable Modules.....	185
9.1 Electrical Interface Attributes.....	186
9.2 Attributes of 10GE Optical Interfaces and 10GE Optical Modules.....	186
9.3 Attributes of GE Optical Interfaces and GE Optical Modules	188
9.4 Attributes of FE Optical Interfaces FE Optical Modules.....	190
9.5 Colored Optical Module Attributes.....	191
9.6 Attributes of a 40G Optical Module.....	194

1 Cabinets

About This Chapter

This chapter describes the N66E and N68E cabinets.

 **NOTE**

- S7700The N68E and N66E cabinets are standard configurations. The cabinets facilitate maintenance and capacity expansion. In addition, two switches can be located in a cabinet side by side.
- In this document, the cabinets as shown in [Figure of Combined N66E cabinets](#) and [Figure of Combined N68E cabinets](#) are not equipped with side panels. When combining two cabinets, you must install side panels on the cabinets. Otherwise, heat dissipation of the S7700 is affected.

[1.1 Introduction to the N66E Cabinet](#)

This topic describes the appearance, technical specifications, components, operating environment, and structural features of the N66E cabinet.

[1.2 Introduction to the N68E Cabinet](#)

This section describes the appearance, technical specifications, components, and structural features of the N68E cabinet.

1.1 Introduction to the N66E Cabinet

This topic describes the appearance, technical specifications, components, operating environment, and structural features of the N66E cabinet.

1.1.1 Appearance of the N66E Cabinet

This topic describes the appearance of the N66E cabinet. Being compliant with the IEC 60297-2 standard, the N66E cabinet is designed with a modular structure, which facilitates expansion and maintenance. The surface of the cabinet and the rack is purplish grey.

Figure 1-1 shows the N66E cabinet.

Figure 1-1 N66E cabinet



1.1.2 Technical Specifications of the N66E Cabinet

This topic describes the technical specifications of the N66E cabinet, including the maximum installation height inside the cabinet, dimensions, and weight of an empty cabinet.

Table 1-1 lists the technical specifications of the N66E cabinet.

Table 1-1 Technical specifications of the N66 cabinet

Cabinet Type	Maximum Installation Height Inside the Cabinet	Dimensions (W x D x H)	Weight of an Empty Cabinet
N66E	46 U	600 mm x 600 mm x 2200 mm	73 kg ± 1 kg
		24" x 24" x 87"	

 **NOTE**

- 1 U = 1.75 in. or 44.45 mm. and U is the height unit defined in the IEC 60297 standard.
- The weight of an empty cabinet consists of the weight of the front door, rear door, and side panels.

1.1.3 Components of the N66E Cabinet

This topic describes the components of the N66E cabinet. N66E cabinets are classified into front-serviceable cabinets and rear-serviceable cabinets. S7700s use rear-serviceable cabinets. A rear-serviceable cabinet consists of a front door, a rear door, two side panels, and a rack.

[Figure 1-2](#) show the components of the rear-serviceable cabinet.

Figure 1-2 Components of the rear-serviceable N66E cabinet

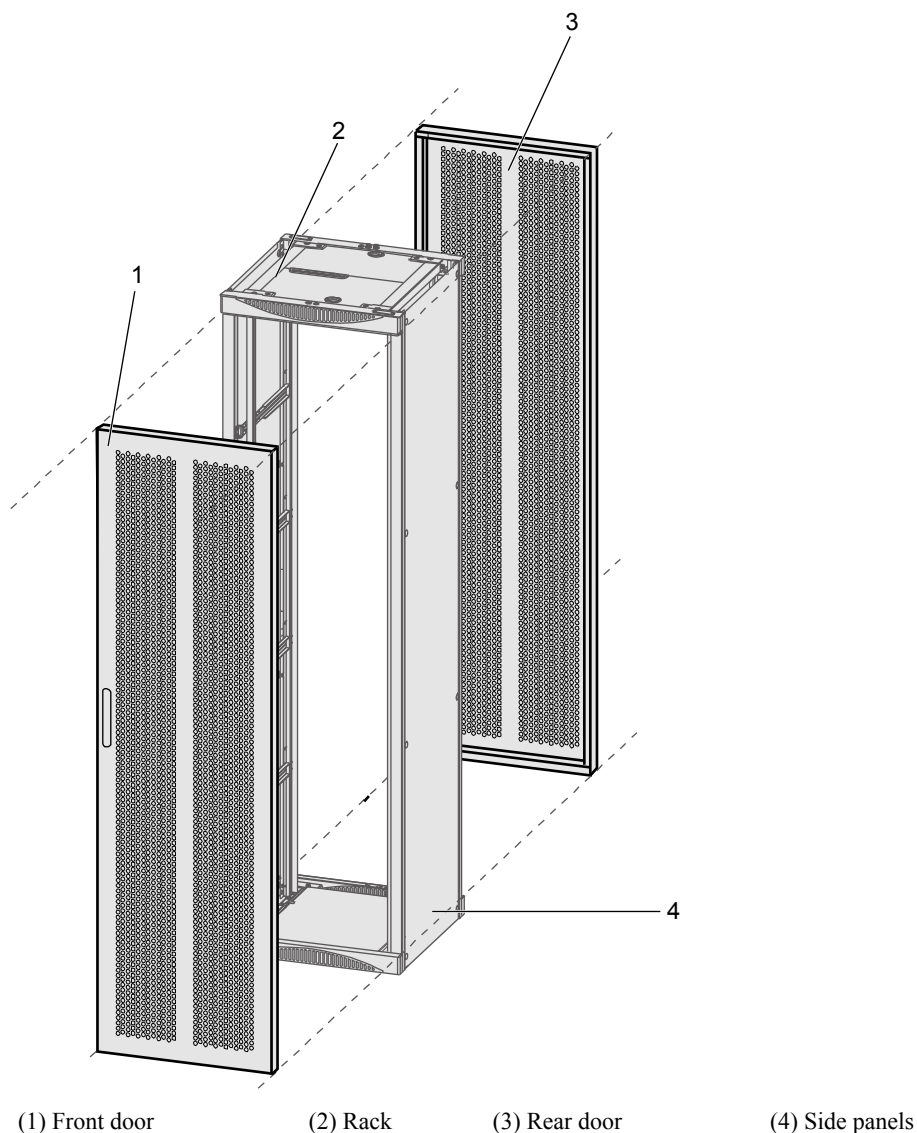

1.1.4 Operating Environment of the N66E Cabinet

This topic describes the ambient temperature and relative humidity in the operating environment of the N66E cabinet.

To ensure long-term reliability of the equipment, the equipment room must have a stable temperature and humidity. [Table 1-2](#) lists the requirements for the operating environment of the N66E cabinet.

Table 1-2 Requirements for the operating environment of the N66E cabinet

Ambient Temperature	Relative Humidity
-25°C to +55°C	5% to 100% RH

 **NOTE**

The temperature and humidity of the equipment room refers to the values measured 1.5 m above the ground and 0.4 m in front of the equipment.

1.1.5 Structural Features of the N66E Cabinet

This topic describes the structural features of the N66E cabinet, including the cabinet material, cabling mode, heat dissipation, protection performance, ESD jack, installation scenarios, and cabinet combination.

Cabinet Material

The surface of the cabinet and the rack is purplish grey.

The N66E cabinet is made of welded electro-galvanized steel sheets and cold-rolled steel sheets. The fireproof performance of the internal materials complies with the Underwriter Laboratories (UL) standards.

Cabling Mode

Cable apertures are reserved on the top and at the bottom of the N66E cabinet, so that the N66E cabinet supports overhead cabling and underfloor cabling:

- In the overhead cabling mode, external cables enter the cabinet through the top of the cabinet. **Figure 1-3** shows the cable apertures.
- In the underfloor cabling mode, external cables enter the cabinet through the bottom of the cabinet.

 **NOTE**

S7700 is in the overhead cabling mode.

Figure 1-3 Cable apertures on the cabinet top

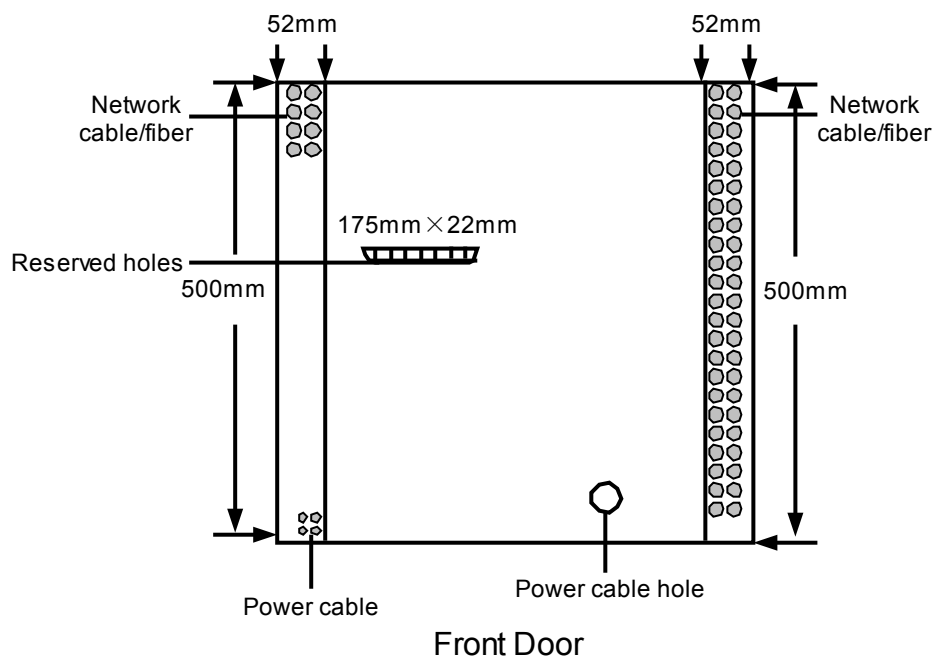

Heat Dissipation

The front door, rear door, and top plate of the N66E cabinet have high-density air vents. Therefore, the cabinet supports front air intake, rear air exhaust, and upper air exhaust and provides good heat dissipation performance.

 **NOTE**

- The S7700 adopts an air channel from the left to the rear side of the equipment for heat dissipation.
- The airflow of S7700 in the cabinet is: front of the cabinet -> left side of the equipment -> inside the equipment -> rear of the equipment -> rear of the cabinet, as shown in [Figure 1-4](#). This ensures good heat dissipation.

Figure 1-4 Airflow in the cabinet

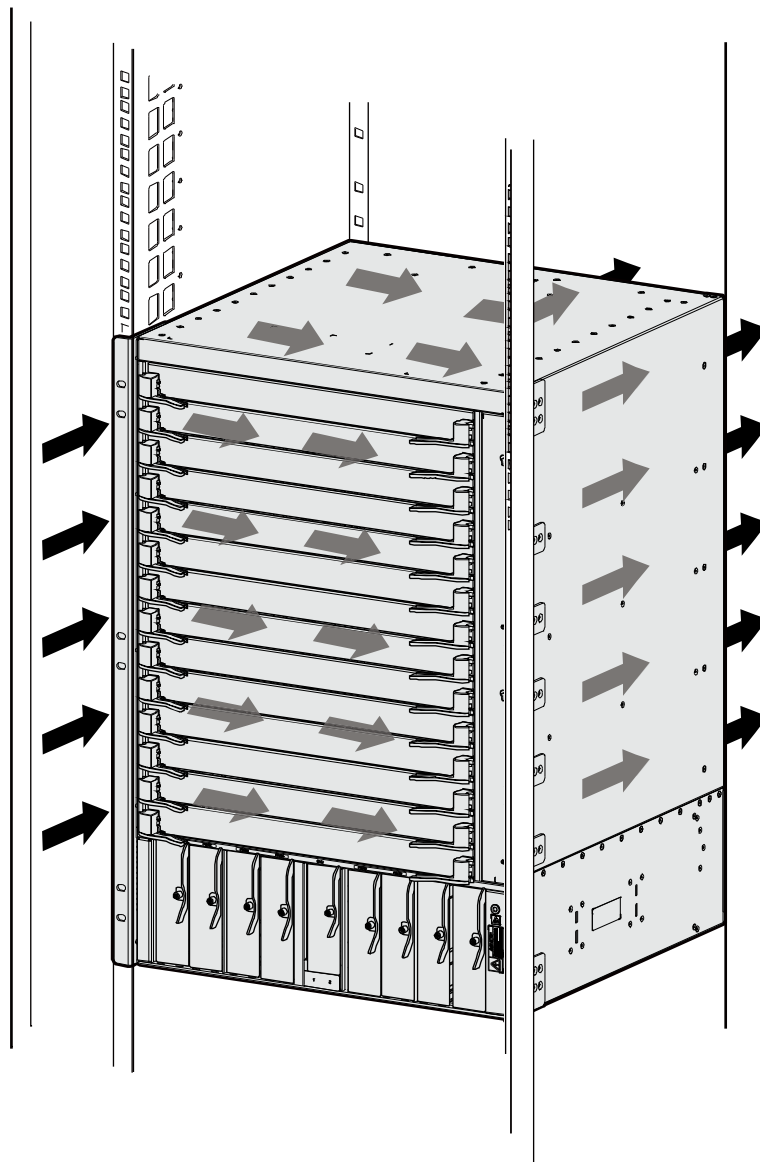

Protective Performance

The protection performance of the N66E cabinet is described as follows:

- The cabinet design takes full account of electromagnetic compatibility (EMC). Therefore, the N66E cabinet has excellent electromagnetic shielding performance.
- The air vents on the bottom plate of the cabinet are installed with air filters, which enhance the dust-proof capability of the N66E cabinet.
- The grounding resistance of the N66E cabinet is equal to or lower than 0.1 ohm.

ESD Jack

When wear an ESD wrist strap, ensure that the connector of the wrist strap is connected properly to the ESD jack in the middle of the N66E cabinet, as shown in [Figure 1-5](#).

Figure 1-5 ESD jack on the N66E cabinet

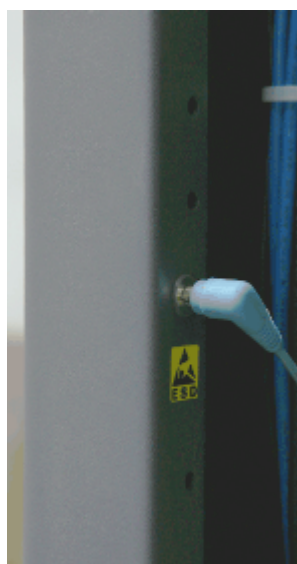

Installation Scenarios

The installation scenarios of the N66E cabinet are as follows:

- The cabinet can be installed on the concrete floor.
- The cabinet can also be installed on the antistatic floor. In this case, the N6X series supports are required.

Cabinet Combination

The N66E cabinets can be installed side by side. When installing the cabinets side by side, connect them by using connecting plates, as shown in [Figure 1-6](#).

Figure 1-6 Combined N66E cabinets

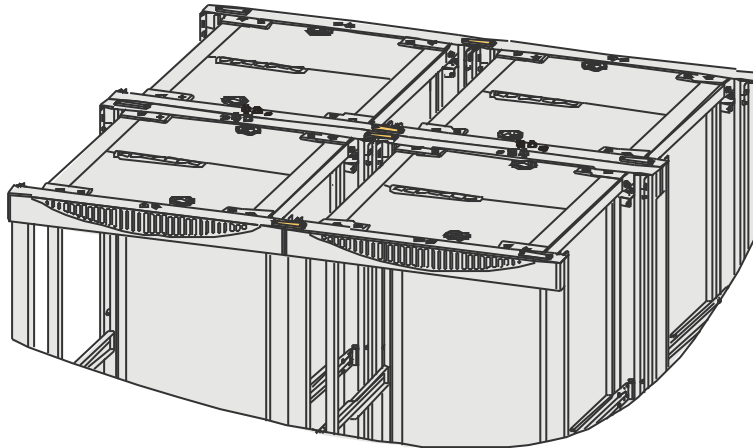

1.2 Introduction to the N68E Cabinet

This section describes the appearance, technical specifications, components, and structural features of the N68E cabinet.

1.2.1 Appearance of the N68E cabinet

The N68E cabinet complies with the requirement of the Dimensions of Mechanical Structures of the 482.6 mm (19 Inch) Series (IEC 60297-2 Standard). The N68E cabinet is designed with a modular structure, which facilitates expansion and maintenance. The surface of the cabinet and the rack is NC purplish grey.

Figure 1-7 shows the appearance of the N68E cabinet.

Figure 1-7 Appearance of the N68E cabinet



1.2.2 Technical Specifications of the N68E cabinet

The technical specifications of the N68E cabinet consist of the maximum installation height inside the cabinet, dimensions, and weight of an empty cabinet.

Table 1-3 lists the technical specifications of the N68E cabinet.

Table 1-3 Technical specifications of the N68E cabinet

Cabinet Type	Maximum Installation Height Inside the Cabinet	Dimension (W x D x H)	Weight of an Empty Cabinet
N68E	46U	600 mm x 800 mm x 2,200 mm	100kg
		24" x 31" x 87"	

 **NOTE**

- 1 U = 1.75 in. or 44.45 mm. U is the height unit defined in the IEC 60297 standard.
- The weight of an empty cabinet includes the weight of the front door, rear door, left side panel, and right side panel.

1.2.3 Components of the N68E cabinet

The N68E cabinet consists of a front door, a rear door, two side panels, and a rack.

Figure 1-8 shows the structure of the N68E cabinet.

Figure 1-8 Structure of the N68E cabinet

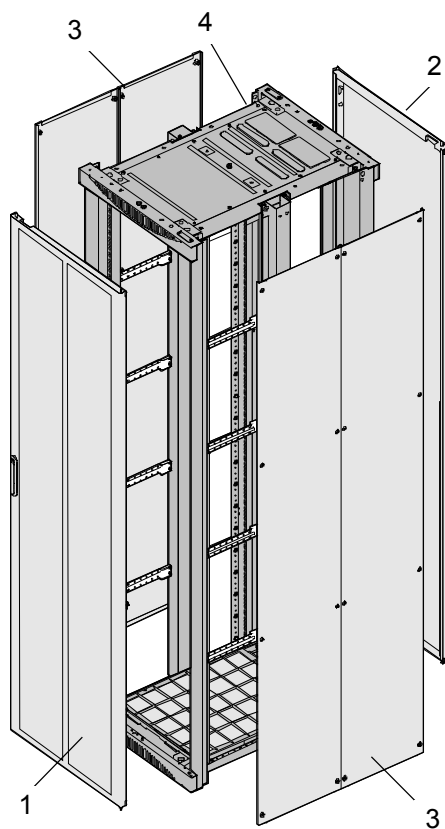

1 Front door

2 Rear door

3 Side panels

4 Rack

1.2.4 Operating Environment of the N68E cabinet

The operating environment of the N68E cabinet is related to the ambient temperature and relative humidity.

To ensure the normal operation of equipment, the equipment room must have a stable temperature and humidity.

Table 1-4 lists the requirements for the operating environment of the N68E cabinet.

Table 1-4 Requirements for the operating environment of the N68E cabinet

Ambient Temperature	Relative Humidity
<ul style="list-style-type: none">● Long term: 5°C to 40°C● Short term: -5°C to +45°C	<ul style="list-style-type: none">● Long term: 5% to 85% RH● Short term: 5% to 90% RH

 **NOTE**

- The temperature and humidity of the equipment room refers to the values measured 1.5 m above the ground and 0.4 m in front of the equipment.
- The short term means that the operating time does not exceed 48 hours continuously or 15 days a year.

1.2.5 Structural Features of the N68E cabinet

The N68E cabinet has the following structural features: cabinet material, cabling mode, ESD jack, heat dissipation, protection performance, installation scenarios, cabinet combination.

Cabinet Material

The N68E cabinet is a cabinet with electro-galvanized steel sheets and cold-rolled steel sheets assembled by screws. The fireproof performance of internal materials complies with the standards of the Underwriter Laboratories (UL).

Cabling Mode

Cable apertures are reserved on the top and at the bottom of the N68E cabinet, so that the N68E cabinet supports overhead cabling and underfloor cabling:

- In the overhead cabling mode, external cables enter the cabinet through the top of the cabinet. [Figure 1-9](#) shows the cable apertures.
- In the underfloor cabling mode, external cables enter the cabinet through the bottom of the cabinet.

 **NOTE**

S7700 is in the overhead cabling mode.

Figure 1-9 Cable apertures on the cabinet top

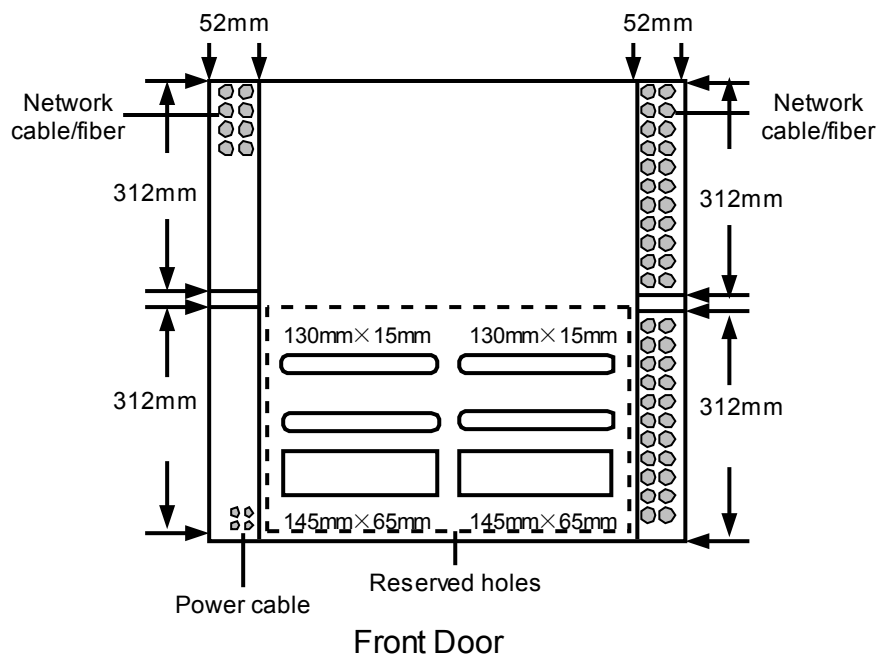

ESD Jack

Before installing the N68E cabinet, you must wear an ESD wrist strap and ensure that the connector of the ESD wrist strap is connected properly to the ESD jack in the middle of the N68E cabinet, as shown in [Figure 1-10](#).

Figure 1-10 ESD jack in the middle of the N68E cabinet



Heat Dissipation

The front door, rear door, and bottom plate of the N68E cabinet have high-density air vents. Therefore, the N68E cabinet supports front air intake, back air exhaust, and upper air exhaust and provides good heat dissipation performance.

NOTE

- The S7700 adopts an air channel from the left to the rear side of the equipment for heat dissipation.
- The airflow of S7700 in the cabinet is: front of the cabinet -> left side of the equipment -> inside the equipment -> rear of the equipment -> rear of the cabinet, as shown in [Figure 1-11](#). This ensures good heat dissipation.

Figure 1-11 Airflow in the cabinet

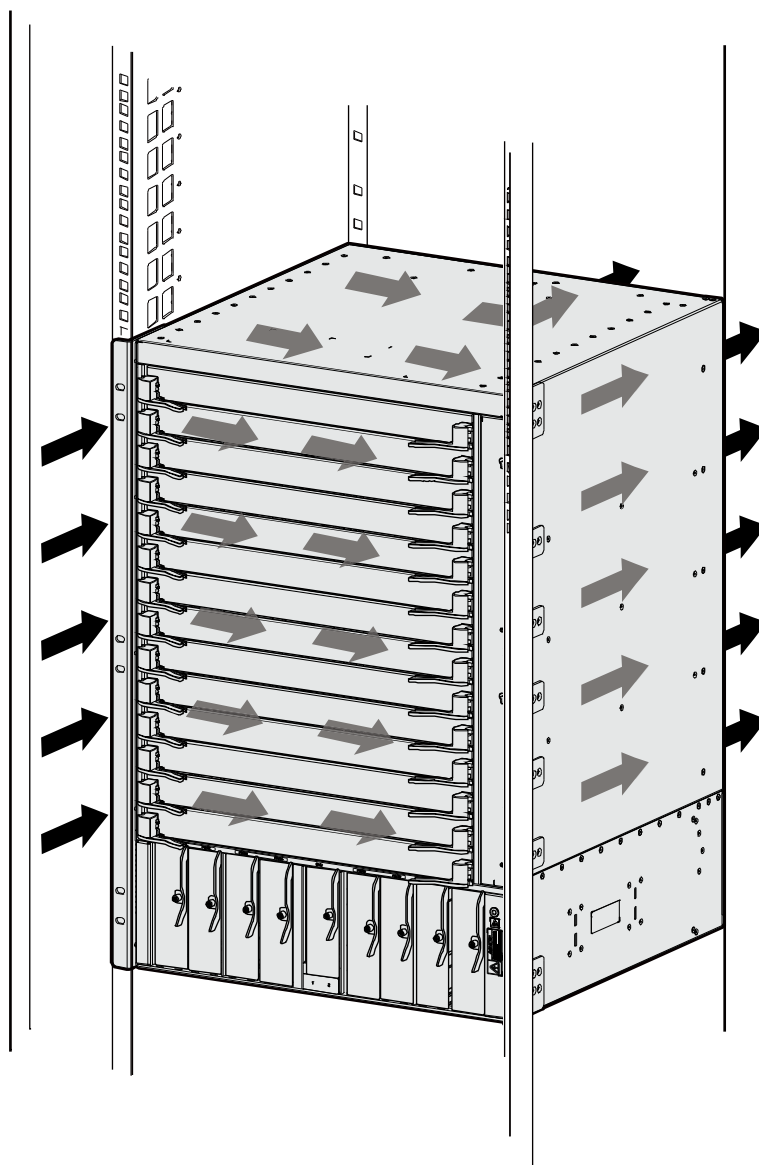

Protection Performance

The protection performance of the N68E cabinet is described as follows:

- The cabinet design takes full account of electromagnetic compatibility (EMC). Therefore, the N68E cabinet has excellent electromagnetic shielding performance.
- The air vents on the bottom plate of the cabinet are installed with air filters. The same enhances the dust-proof capability of the N68E cabinet.
- The grounding resistance of the N68E cabinet does not exceed 0.1 ohm.

Installation Scenarios

The installation scenarios of the N68E cabinet are as follows:

- The N68E cabinet can be installed on the concrete floor.
- The N68E cabinet can also be installed on the antistatic floor. In such a case, the N6X series supports are required.

Cabinet Combination

The N68E cabinets can be installed side by side. When installing the N68E cabinets side by side, connect them by using connecting plates, as shown in [Figure 1-12](#).

Figure 1-12 Combined N68E cabinets

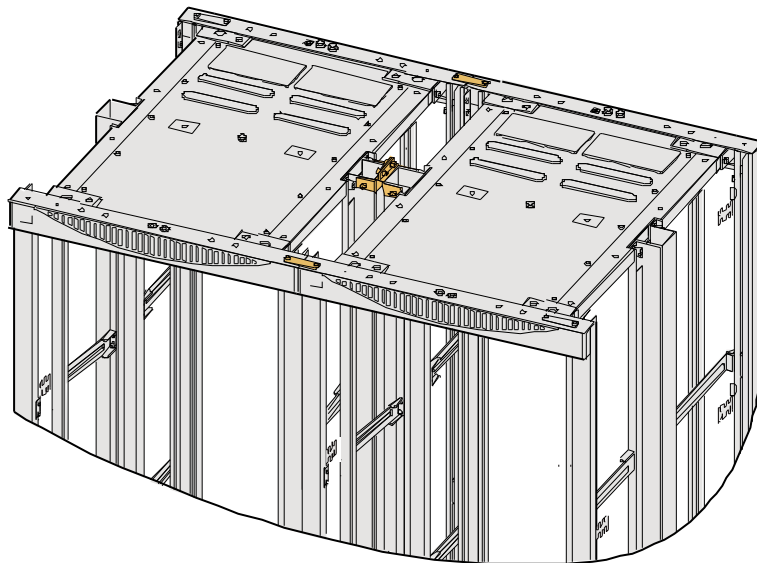

2 Chassis

About This Chapter

This chapter describes the characteristics, structure, system parameters, and physical specifications of the S7700.

[2.1 Introduction](#)

This section describes the characteristics of the S7700.

[2.2 Hardware Structure](#)

This section describes the hardware structure of the S7700.

[2.3 System Configuration and Physical Specifications](#)

This section describes the system configuration and physical specifications of the S7700.

2.1 Introduction

This section describes the characteristics of the S7700.

Position

The S7700 is a high-end Ethernet switch with a large capacity and high performance. It functions as an access switch or aggregation switch on a metropolitan area network (MAN) or a core switch on an enterprise network, providing fast Ethernet (FE), gigabit Ethernet (GE), and 10GE interfaces.

Models

The following models of S7700 products are available:

- S7703 switch (S7703 for short): supports double MCUs, three LPUs, and AC or DC power supplies in 1+1 backup mode.
- S7706 switch (S7706 for short): supports double SRUs, six LPUs, and DC power supplies in 1+1 backup mode or AC power supplies in 1+1 or 2+2 backup mode.
- S7712 switch (S7712 for short): supports double SRUs, 12 LPUs, and DC power supplies in 1+1 backup mode or AC power supplies in 1+1 or 2+2 backup mode.

The S7703, S7706, and S7712 have different capacities and structures but they use the same software platform, hardware platform, LPUs, and software. Two types of main processing units (MPUs) are available:

- SRU: used by the S7706 and the S7712.
- MCU: used by the S7703 and integrates the functions of the centralized monitoring unit (CMU) on the S7706 and S7712.

Select the product type according to the networking requirements.

2.2 Hardware Structure

This section describes the hardware structure of the S7700.

2.2.1 S7712

The S7712 is 15 U (1 U = 44.45 mm) high. When the chassis has no cable management frame installed, the dimensions are 442 mm x 489 mm x 663.95 mm (W x D x H). When the chassis has cable management frames installed, the dimensions are 442 mm x 585 mm x 663.95 mm (W x D x H). [Figure 2-1](#) and [Figure 2-2](#) show the appearance and components of the S7712. [Figure 2-3](#) shows the layout of slots on the S7712.

Figure 2-1 Appearance and components of the S7712 (1)

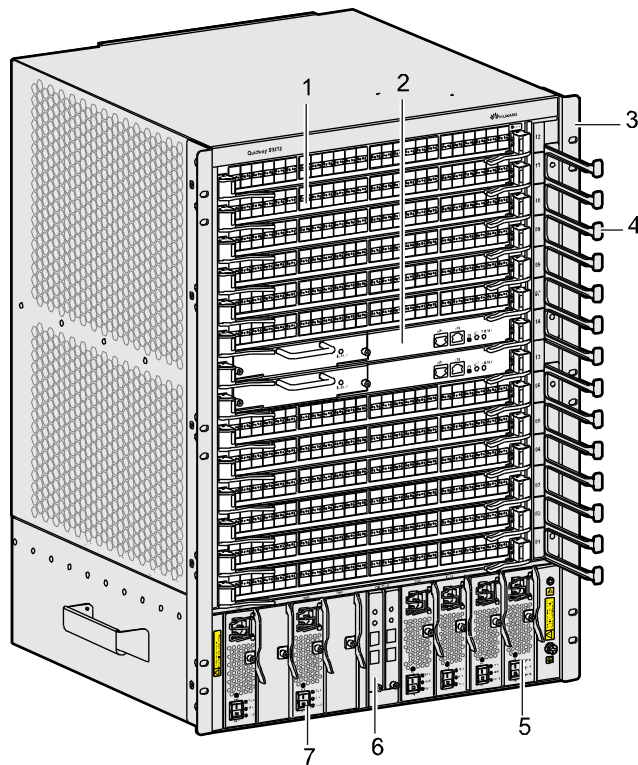

- | | | |
|---------------------------|---------------------|----------------------|
| 1. LPU | 2. SRU | 3. Rack-mounting ear |
| 4. Cable management frame | 5. PoE power module | 6. CMU |
| 7. Power supply | | |

Figure 2-2 Appearance and components of the S7712 (2)

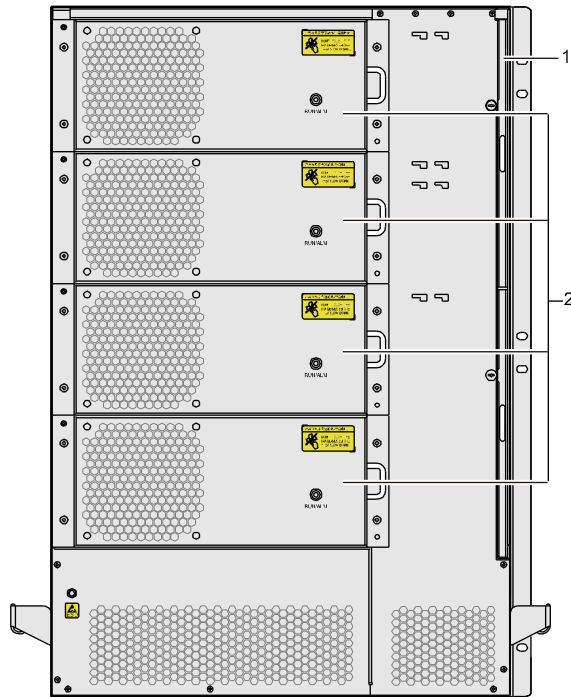

1. Air filter

2. Fan

Figure 2-3 Layout of slots on the S7712

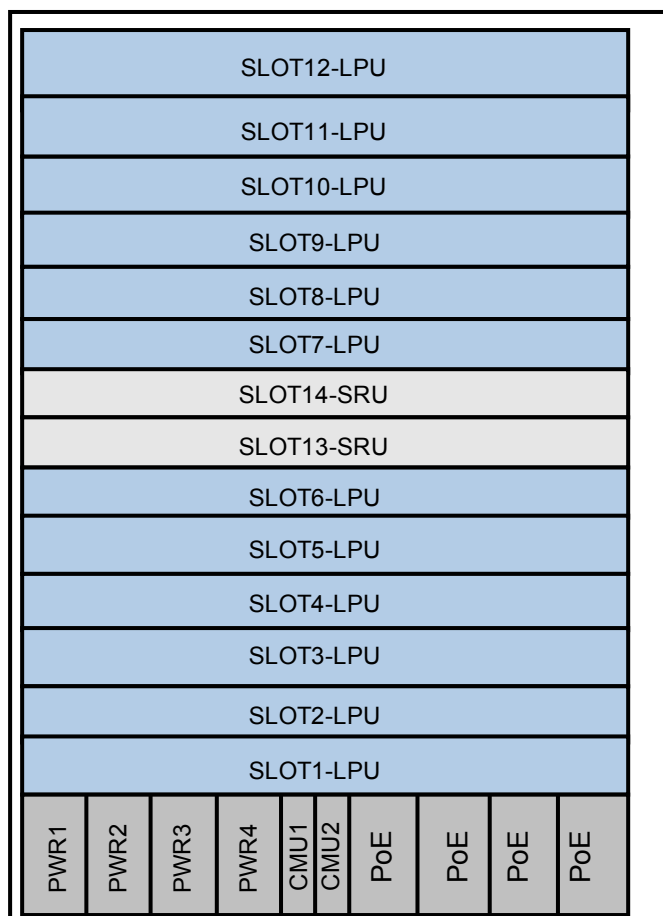

The S7712 uses an integrated chassis of which the main components are described in [Table 2-1](#).

Table 2-1 Components of the S7712

Component	Description	Reference
SRU	The SRUs are installed in slot 13 and slot 14 and work in 1+1 hot backup mode with the data switching units working in load balancing mode. The interval between slot 13 and slot 14 is 1.4 inches.	See 5.2 SRU-Main Control Unit .
LPU	The LPUs are installed in slots 1-12. The interval between each two slots is 1.4 inches.	See 5 Boards .
CMU	The CMUs are installed in slots CMU1 and CMU2, working in 1+1 hot backup mode.	See 5.6 CMU - Centralized Monitoring Unit .

Component	Description	Reference
Fan module	The fan modules are installed at the rear of the equipment. The equipment must be equipped with four fan modules.	See 4.2 Fan Module .
Power supply	The power supplies are installed in slots PWR1 to PWR4. The S7712 can use DC or AC power supplies.	See 3 Power Supply .
Cable management frame	The cable distribution posts are located on the right side of the board cage of the S7712.	-
Cable	The cables of the S7712 include internal cables (such as power cables and signal cables), optical fibers, and external cables.	See 6 Cables .

 **NOTE**

Only AC power supplies can be installed in PoE power slots. On an S7700, the 2200 W AC power supply can only be installed in the PoE slot.

- When an AC power supply is inserted into the PoE power slot, it is used as a PoE power supply, and provides power for powered devices (PDs) by using the Ethernet PoE electrical interface board.
- When an AC power supply is inserted into slots PWR1 to PWR4, it provides power for the entire device.
- The S7712 has PoE chassis and non-PoE chassis, which are identified by the nameplates and silkscreens on power slots.

2.2.2 S7706

The S7706 is 10 U (1 U = 44.45 mm) high. When the chassis has no cable management frame installed, the dimensions are 442 mm x 489 mm x 441.7 mm (W x D x H). When the chassis has cable management frames installed, the dimensions are 442 mm x 585 mm x 441.7 mm (W x D x H). [Figure 2-4](#) and [Figure 2-5](#) show the appearance and components of the S7706. [Figure 2-6](#) shows the layout of slots on the S7706.

Figure 2-4 Appearance and components of the S7706 (1)

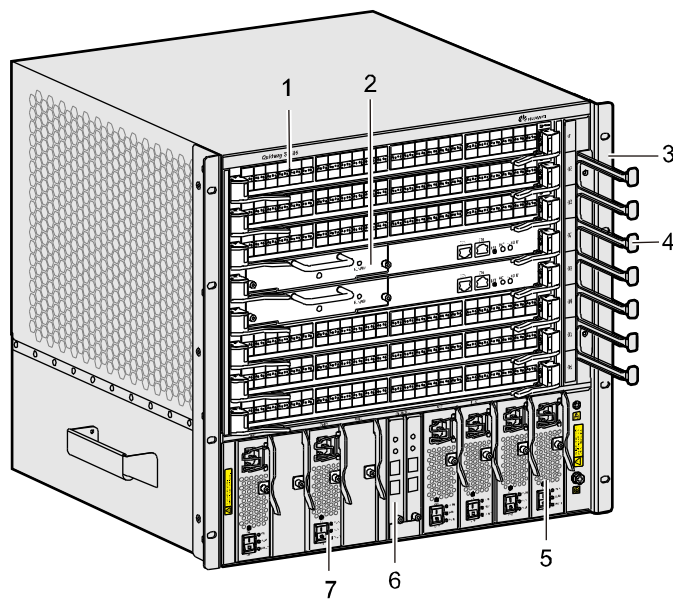

- | | | |
|---------------------------|---------------------|----------------------|
| 1. LPU | 2. SRU | 3. Rack-mounting ear |
| 4. Cable management frame | 5. PoE power module | 6. CMU |
| 7. Power supply | | |

Figure 2-5 Appearance and components of the S7706 (2)

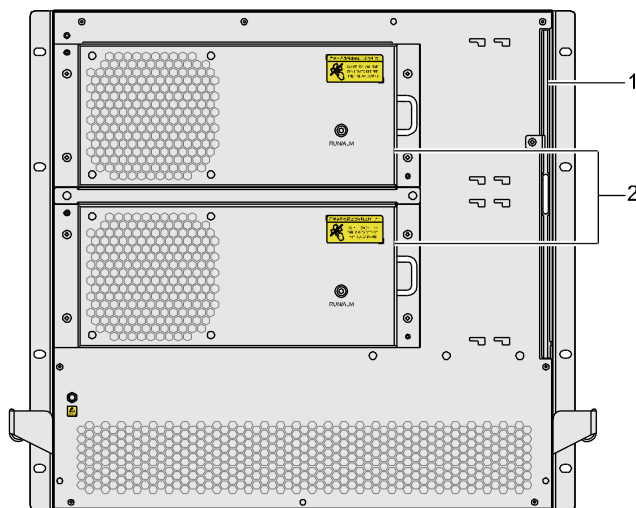

- | | |
|---------------|--------|
| 1. Air filter | 2. Fan |
|---------------|--------|

Figure 2-6 Layout of slots on the S7706

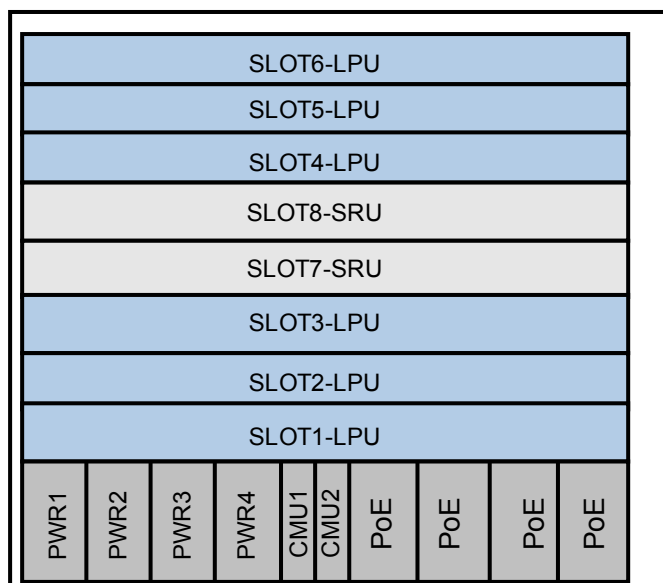

The S7706 uses an integrated chassis of which the main components are described in [Table 2-2](#).

Table 2-2 Components of the S7706

Component	Description	Reference
SRU	The SRUs are installed in slot 7 and slot 8 and work in 1+1 hot backup mode with the data switching units working in load balancing mode. The interval between slot 7 and slot 8 is 1.4 inches.	See 5.2 SRU-Main Control Unit .
LPU	The LPUs are installed in slots 1-6. The interval between each two slots is 1.4 inches.	See 5 Boards .
CMU	The CMUs are installed in slots CMU1 and CMU2, working in 1+1 hot backup mode.	See 5.6 CMU - Centralized Monitoring Unit .
Fan module	The fan modules are installed at the rear of the equipment. The equipment must be equipped with two fan modules.	See 4.2 Fan Module .
Power supply	The power supplies are installed in slots PWR1 to PWR4. The S7706 can use DC or AC power supplies.	See 3 Power Supply .
Cable management frame	The cable distribution posts are located on the right side of the board cage of the S7706.	-

Component	Description	Reference
Cable	The cables of the S7706 include internal cables (such as power cables and signal cables), optical fibers, and external cables.	See 6 Cables .

NOTE

- Only AC power supplies can be installed in PoE power slots. On an S7700, the 2200 W AC power supply can only be installed in the PoE slot.
- When an AC power supply is inserted into the PoE power slot, it is used as a PoE power supply, and provides power for powered devices (PDs) by using the Ethernet PoE electrical interface board.
- When an AC power supply is inserted into slots PWR1 to PWR4, it provides power for the entire device.
- The S7706 has PoE chassis and non-PoE chassis, which are identified by the nameplates and silkscreens on power slots.

2.2.3 S7703

The S7703 is 4 U (1 U = 44.45 mm) high. When the chassis has no cable management frame installed, the dimensions are 442 mm x 489 mm x 175 mm (W x D x H). When the chassis has cable management frames installed, the dimensions are 442 mm x 585 mm x 175 mm (W x D x H). [Figure 2-7](#) and [Figure 2-8](#) show the appearance and components of the S7703. [Figure 2-9](#) shows the layout of slots on the S7703.

Figure 2-7 Appearance and components of the S7703 (1)

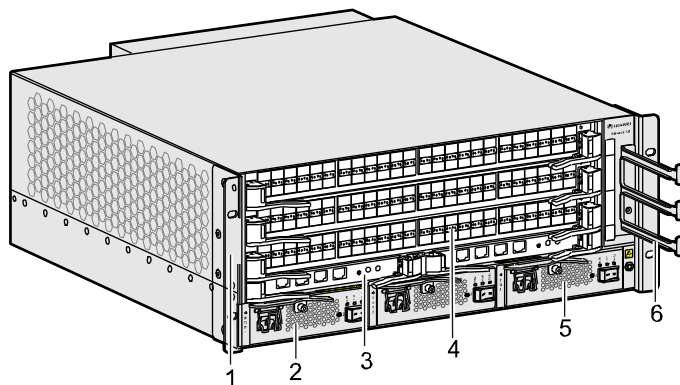

- | | | |
|----------------------|---------------------|---------------------------|
| 1. Rack-mounting ear | 2. Power supply | 3. MCU |
| 4. LPU | 5. PoE power module | 6. Cable management frame |

Figure 2-8 Appearance and components of the S7703 (2)

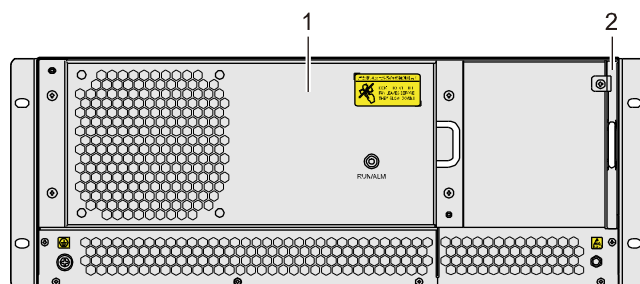

1. Fan

2. Air filter

Figure 2-9 Layout of slots on the S7703

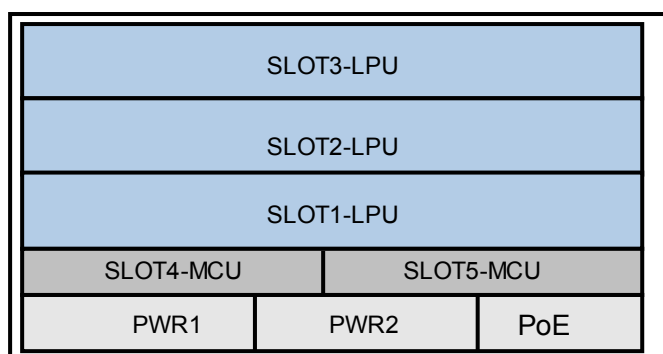

The S7703 uses an integrated chassis of which the main components are described in [Table 2-3](#).

Table 2-3 Components of the S7703

Component	Description	Reference
MCU	The MCUs are installed in slot 4 and slot 5 and work in 1+1 hot backup mode. The interval between slot 4 and slot 5 is 0.8 inches.	See 5.3 MCUA-Main Control Unit .
LPU	The LPUs are installed in slots 1-3. The interval between each two slots is 1.4 inches.	See 5 Boards .
Fan module	The fan modules are installed at the rear of the equipment. The equipment must be equipped with one fan module.	See 4.2 Fan Module .
Power supply	The power supplies are installed in slots PWR1 and PWR2. The S7703 can use DC or AC power supplies.	See 3 Power Supply .

Component	Description	Reference
Cable management frame	The cable distribution posts are located on the right side of the board cage of the S7703.	-
Cable	The cables of the S7703 include internal cables (such as power cables and signal cables), optical fibers, and external cables.	See 6 Cables .

 **NOTE**

- Only AC power supplies can be installed in PoE power slots. On an S7700, the 2200 W AC power supply can only be installed in the PoE slot.
- When an AC power supply is inserted into the PoE power slot, it is used as a PoE power supply, and provides power for powered devices (PDs) by using the Ethernet PoE electrical interface board.
- When an AC power supply is inserted into slots PWR1 to PWR2, it provides power for the entire device.

2.3 System Configuration and Physical Specifications

This section describes the system configuration and physical specifications of the S7700.

2.3.1 System Configuration

This section describes the switching capacity, backplane capacity, and forwarding rate of the S7700.

Table 2-4 System configuration of the S7700

Item	S7712	S7706	S7703	Notes
Processor	700MHz (Dominant frequency)	700MHz (Dominant frequency)	500 MHz (Dominant frequency)	-
DDR2 SDRAM	1GB	1GB	512 MB	-
NVRAM	512 KB	512 KB	512 KB	Battery supply
Flash	64MB	64MB	64 MB	-
CF card	512 MB	512 MB	512 MB	The CF card serves as a mass storage device to save data files and logs.

Item	S7712	S7706	S7703	Notes
Switching capacity (bit/s)	2T NOTE The switching capacity can be expanded to 5.12 Tbit/s in the future.	2T NOTE The switching capacity can be expanded to 5.12 Tbit/s in the future.	768G NOTE The switching capacity can be expanded to 1.92 Tbit/s in the future.	Bidirectional, sum of switching capacities of the two MPUs
Backplane capacity (bit/s)	12T	6T	3T	-
Forwarding capability (pps)	1344M NOTE The forwarding capability can be expanded to 3360 Mpps in the future.	1152M NOTE The forwarding capability can be expanded to 2880 Mpps in the future.	576M NOTE The forwarding capability can be expanded to 1440 Mpps in the future.	-
Number of LPU slots	12	6	3	LPU (Optional)
Number of SRU/MCU slots	2	2	2	S7706/S7712: SRU S7703: full mesh
Max transmission rate of an LPU port	48×GE, 40×10GE	48×GE, 40×10GE	48×GE, 40×10GE	-

Calculating Switching Capacity and Interface Capacity

- Calculating the switching capacity
 - Switching capacities of S7706 and S7712
Switching capacity = Switching capacity of an SRU x Number of SRUs
 - Switching capacity of S7703
The bidirectional forwarding rate in each slot is 128 Gbit/s.
Use S7703 as an example. Switching capacity = 128 x 3 x 2 = 768 (Gbit/s). The value 3 indicates the number of slots on S7703 and the value 2 indicates bidirectional forwarding.
- Calculating the interface capacity
The interface capacity of the S7700 is calculated using the following formula:
Interface capacity = Maximum interface rate x Interface density
 - The maximum interface rate is the maximum transmission rate on each interface.

- The interface density indicates the number of a specified type of interfaces on the S7700.

For example:

Each LPU of the supports a maximum of 48 GE interfaces. Take S7712 for example. A switch has 12 slots, which can accommodate twelve 48-port GE interface LPUs. The entire device can provide a maximum of 576 GE interfaces. That is, the interface density is 576. The transmission rate of each GE interface is 1 Gbit/s; therefore, the interface capacity of the S7712 is 576 Gbit/s.

2.3.2 Physical Specifications

This section describes the dimensions, power consumption, weight, voltage, and working environment parameters of the S7700.

Table 2-5 Physical specifications of the S7700

Item	S7712	S7706	S7703
Dimensions (W x D x H, excluding the rack-mounting ears)	442 mm x 489 mm x 663.95 mm (15 U high)	442 mm x 489 mm x 441.7 mm (10 U high)	442 mm x 489 mm x 175 mm (4 U high)
Cabinet	N66E or N68E	N66E or N68E	N66E or N68E
Maximum power (full configuration) NOTE The heat dissipation value of a device equals the current power consumption of the device.	3000 W	1600 W	800 W
Noise at normal temperature (acoustic power)	≤ 72 dB	≤ 72 dB	≤ 72 dB
Weight (empty/fully loaded)	25 kg/70 kg	15 kg/42 kg	10 kg/22 kg
DC input	Rated voltage	-48 V DC/-60 V DC	

Item		S7712	S7706	S7703
	Maximum voltage range	-48 V: -38.4 V DC to -57.6 V DC -60 V: -48 V DC to -72 V DC		
AC input	Rated voltage	220 V AC, 50/60 Hz	110/220 V AC, 50/60 Hz	110/220 V AC, 50/60 Hz
	Rated voltage range	200 V AC to 240 V AC, 47 Hz to 63 Hz	100 V AC to 120 V AC and 200 V AC to 240 V AC, 47 Hz to 63 Hz	100 V AC to 120 V AC and 200 V AC to 240 V AC, 47 Hz to 63 Hz
	Maximum voltage range	90 V AC to 290 V AC (The output power is half of the maximum power when the input voltage is in the range of 90 V AC to 175 V AC.)		
PoE	Power input mode	Built-in. Only the AC power supply is supported.	Built-in. Only the AC power supply is supported.	Built-in. Only the AC power supply is supported.
	Redundancy mode of power supplies	The S7712 supports power supplies in 3+1, 2+2, or 4+0 mode.	The S7706 supports power supplies in 3+1, 2+2, or 4+0 mode.	The S7703 does not support backup of AC power modules.
	Output power consumption	8800 W	8800 W	2200 W
Environment parameters	<ul style="list-style-type: none"> ● Operating temperature and altitude: <ul style="list-style-type: none"> - -60 m to 1800 m: 0°C to 45°C - 1800 m to 4000 m: Temperature decreases by 1°C every time the altitude increases 200 m. - 4000 m: 0°C to 35°C ● Operating relative humidity: 5% RH to 85% RH (non-condensing) ● Storage temperature: -40°C to +70°C ● Storage altitude: < 5000 m ● Storage relative humidity: 0% RH to 95% RH (non-condensing) 			

 **NOTE**

The temperature and humidity are measured 1.5 m above the floor and 0.4 m at the front of the cabinet. There should be no protection board at the front or back of the cabinet.

3 Power Supply

About This Chapter

This chapter describes the AC power supply and DC power supply of the S7700.

[3.1 Introduction](#)

This section provides an overview of AC power supplies and DC power supplies on the S7700.

[3.2 1600 W DC Power Supply](#)

This section describes the panel, functions, and technical specifications of 1600 W DC power supplies on the S7700.

[3.3 800 W AC Power Supply](#)

This section describes the appearance, panel, functions, and technical specifications of an 800 W AC power supply on the S7700.

[3.4 2200 W AC Power Supply](#)

This section describes the appearance, panel, functions, and technical specifications of the 2200 W AC power supply.

3.1 Introduction

This section provides an overview of AC power supplies and DC power supplies on the S7700.



CAUTION

- Do not install an AC power supply and a DC power supply on the same S7700.
 - Ensure that the S7700 is properly grounded before powering it on.
 - Power off the S7700 before removing a power supply.
 - Do not operate power supplies when the switch is running.
 - When powering off the S7700, shut down all the power supplies of the S7700.
-

3.1.1 Configuration and Operation Modes of Power Supplies



NOTE

This section describes the configuration of the power supplies that ensure proper operation of the S7700.

S7712

On the S7712, system power supplies are located in slots PWR1 to PWR4. The S7712 supports both DC and AC power supplies. PWR1 and PWR2 are in area A, and PWR3 and PWR4 are in area B. Area A and area B work in backup mode, as shown in [Figure 3-1](#). PWR1 and PWR2 work in load balancing mode. PWR3 and PWR4 work in load balancing mode.

A DC power supply and an AC power supply cannot be located in the same area.

Figure 3-1 Configuration of S7712 power supplies

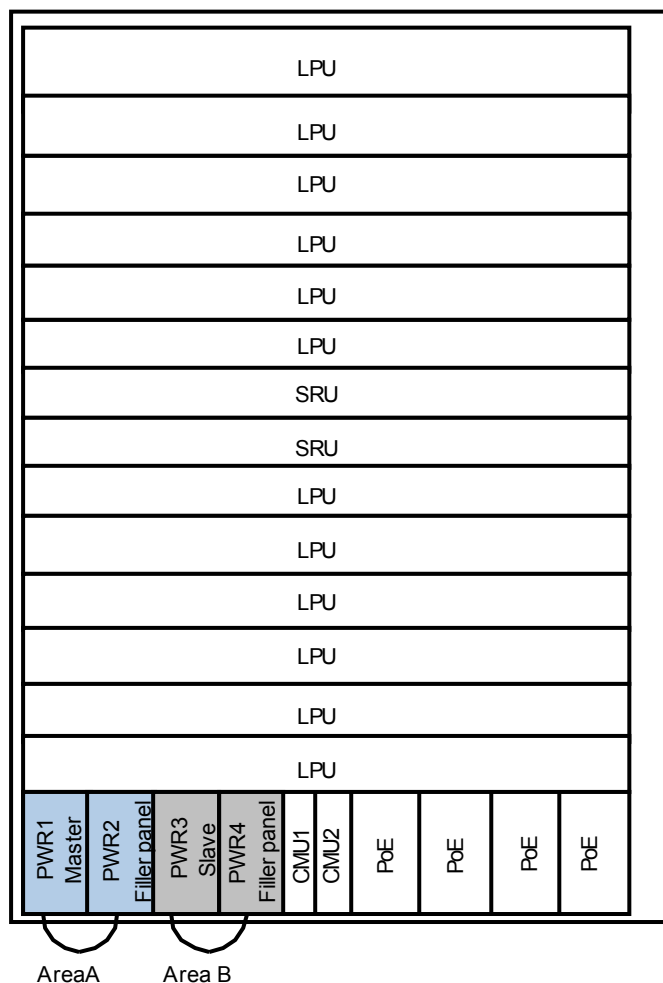

The S7712 both DC and AC power supplies.

- Configuration of S7712 DC power supplies

The S7712 supports two 1600 W DC power supplies in 1+1 backup mode.

Two 1600 W DC power supplies are installed in active area A and standby area B. Filler panels are installed in empty slots of area A and area B, as shown in [Figure 3-1](#). This configuration provides a maximum of 1600 W power.

Example:

- DC power supplies are installed in PWR1 and PWR3, and the filler panels are installed in PWR2 and PWR4.
- DC power supplies are installed in PWR1 and PWR4, and the filler panels are installed in PWR2 and PWR3.
- DC power supplies are installed in PWR2 and PWR3, and the filler panels are installed in PWR1 and PWR4.
- DC power supplies are installed in PWR2 and PWR4, and the filler panels are installed in PWR1 and PWR3.

- Configuration of S7712 AC power supplies

The S7712 supports two AC power supplies in 1+1 backup mode or four AC power supplies in 2+2 backup mode.

Use the 1+1 or 2+2 backup mode according to the power supply requirements of the system.

- 220 V AC power supplies in 1+1 backup mode (800 W)

This configuration provides a maximum of 800 W power. This backup mode is used if the S7712 has a few LPUs and the total power consumption of the device is less than 800 W.

AC power supplies are installed in active area A and standby area B. Filler panels are installed in empty slots of area A and area B, as shown in [Figure 3-1](#).

Example:

- AC power supplies are installed in PWR1 and PWR3, and the filler panels are installed in PWR2 and PWR4.
- AC power supplies are installed in PWR1 and PWR4, and the filler panels are installed in PWR2 and PWR3.
- AC power supplies are installed in PWR2 and PWR3, and the filler panels are installed in PWR1 and PWR4.
- AC power supplies are installed in PWR2 and PWR4, and the filler panels are installed in PWR1 and PWR3.
- 220 V AC power supplies in 2+2 backup mode (1600 W)

This configuration provides a maximum of 1600 W power. Four AC power supplies are installed in active area A and standby area B. The AC power supplies are installed in slots PWR1 to PWR4.

- The S7712 does not support 110 V AC input power.

A maximum of four PoE power supplies can be installed on an S7712. The PoE power supplies work in 3+1 or 2+2 backup mode, or do not work in backup mode.

- 800 W power supply

- When the power supplies do not work in backup mode, a maximum of 3200 W power is provided.
- When the power supplies work in 3+1 backup mode, a maximum of 2400 W power is provided. PoE4 slot shown in [Figure 3-1](#) is provided for backup PoE power supply.
- When the power supplies work in 2+2 backup mode, a maximum of 1600 W power is provided. PoE3 and PoE4 slots shown in [Figure 3-1](#) are provided for backup PoE power supplies.

- 2200 W power supply

- When the power supplies do not work in backup mode, a maximum of 8800 W power is provided.
- When the power supplies work in 3+1 backup mode, a maximum of 6600 W power is provided. PoE4 slot shown in [Figure 3-1](#) is provided for backup PoE power supply.
- When the power supplies work in 2+2 backup mode, a maximum of 4400 W power is provided. PoE3 and PoE4 slots shown in [Figure 3-1](#) are provided for backup PoE power supplies.

 **NOTE**

The 2200 W AC power supply provides only PoE power, but does not provide power for the entire device.

S7706

On the S7706, system power supplies are located in slots PWR1 to PWR4. The DC power supplies and AC power supplies are supported. PWR1 and PWR2 are in area A, and PWR3 and PWR4 are in area B. Area A and area B work in backup mode, as shown in [Figure 3-2](#). PWR1 and PWR2 work in load balancing mode. PWR3 and PWR4 work in load balancing mode.

A DC power supply and an AC power supply cannot be located in the same area.

Figure 3-2 Configuration of S7706 power supplies

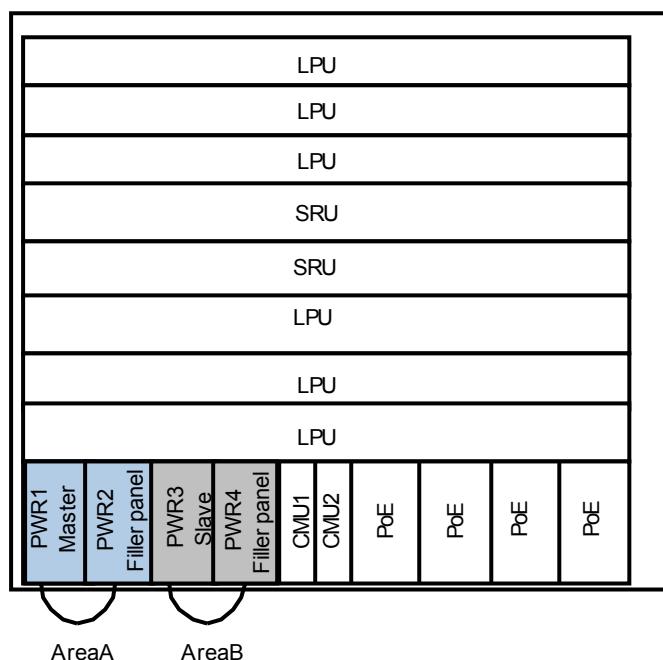

You can use DC power supplies or AC power supplies on the S7706.

- Configuration of S7706 DC power supplies

The S7712 supports two 1600 W DC power supplies in 1+1 backup mode.

Two 1600 W DC power supplies are installed in active area A and standby area B. Filler panels are installed in empty slots of area A and area B, as shown in [Figure 3-2](#). This configuration provides a maximum of 1600 W power.

Example:

- DC power supplies are installed in PWR1 and PWR3, and the filler panels are installed in PWR2 and PWR4.
- DC power supplies are installed in PWR1 and PWR4, and the filler panels are installed in PWR2 and PWR3.
- DC power supplies are installed in PWR2 and PWR3, and the filler panels are installed in PWR1 and PWR4.
- DC power supplies are installed in PWR2 and PWR4, and the filler panels are installed in PWR1 and PWR3.

- Configuration of S7706 AC power supplies

- 220 V AC power supplies in 1+1 backup mode (800 W)
This configuration provides a maximum of 800 W power. Two power supplies are installed in active area A and standby area B. Filler panels are installed in empty slots of area A and area B, as shown in [Figure 3-2](#).
Example:
 - AC power supplies are installed in PWR1 and PWR3, and the filler panels are installed in PWR2 and PWR4.
 - AC power supplies are installed in PWR2 and PWR3, and the filler panels are installed in PWR1 and PWR4.
 - AC power supplies are installed in PWR2 and PWR4, and the filler panels are installed in PWR1 and PWR3.
 - AC power supplies are installed in PWR1 and PWR4, and the filler panels are installed in PWR2 and PWR3.
- 220 V AC power supplies in 2+2 backup mode (1600 W)
This configuration provides a maximum of 1600 W power. Four AC power supplies are installed in active area A and standby area B. The AC power supplies are installed in slots PWR1 to PWR4.
- 110 V AC power supplies in 2+2 backup mode (800 W)
One 110 V AC power supply provides 400 W power. To meet power requirement of the S7706, the backup mode must be used for 110 V AC power supplies. The AC power supplies are installed in the PWR1 to PWR4 slots.

A maximum of four PoE power supplies can be installed on an S7706. The PoE power supplies work in 3+1 or 2+2 backup mode, or do not work in backup mode.

- 800 W power supply unit
 - When the power supplies do not work in backup mode, a maximum of 3200 W power is provided.
 - When the power supplies work in 3+1 backup mode, a maximum of 2400 W power is provided. PoE4 slot shown in [Figure 3-2](#) is provided for backup PoE power supply.
 - When the power supplies work in 2+2 backup mode, a maximum of 1600 W power is provided. PoE3 and PoE4 slots shown in [Figure 3-2](#) are provided for backup PoE power supplies.
- 2200 W power supply
 - No backup: When 220 V power source is used, the power supplies provide a maximum of 8800 W power. When 110 V power source is used, the power supplies provide a maximum of 4400 W power.
 - 3+1 backup: The power supply in PoE4 slot works as a backup PoE power supply, as shown in [Figure 3-2](#). When 220 V power source is used, the power supplies provide a maximum of 6600 W power. When 110 V power source is used, the power supplies provide a maximum of 3300 W power.
 - 2+2 backup: The power supplies in PoE3 and PoE4 slots work as backup PoE power supplies, as shown in [Figure 3-2](#). When 220 V power source is used, the power supplies provide a maximum of 4400 W power. When 110 V power source is used, the power supplies provide a maximum of 2200 W power.

 **NOTE**

The 2200 W AC power supply provides only PoE power, but does not provide power for the entire device. When the input voltage for an S7706 is 110 V, confirm with Huawei technical personnel to determine the power supply configuration.

S7703

On the S7703, system power supplies are located in slots PWR1 to PWR2. The S7703 supports both DC and AC power supplies. PWR1 is in area A, and PWR2 is in area B. Area A and area B work in backup mode, as shown in [Figure 3-3](#).

Figure 3-3 Configuration of S7703 power supplies

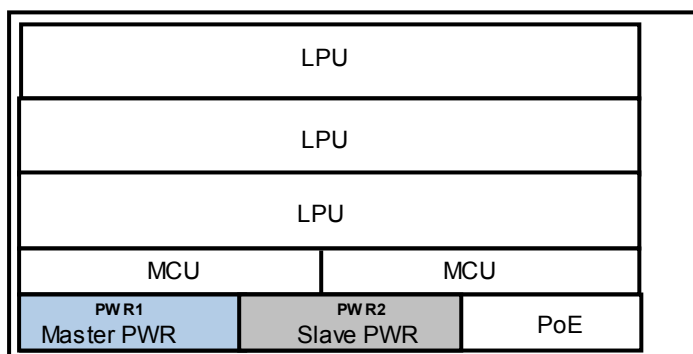

The following describes the AC and DC power supply configurations:

- Configuration of S7703 DC power supplies
DC power supplies in 1+1 backup mode (1600 W)
Two power supplies are installed in active area A and standby area B and work in backup mode, as shown in [Figure 3-3](#).
- Configuration of S7703 AC power supplies
 - 220 V AC power supplies in 1+1 backup mode (800 W)
This configuration provides a maximum of 800 W power. Two AC power supplies are installed in active area A and standby area B, as shown in [Figure 3-3](#).
 - 110 V AC power supplies in 1+1 backup mode (400 W)
Two 110 V AC power supplies provide 400 W power. The total power consumption of the S7703 is less than 400 W; therefore, the S7703 can use two 110 V AC power supplies in backup mode, as shown in [Figure 3-3](#).

Only one PoE power supply can be installed on an S7703. The PoE power supplies include:

- 800 W PoE power supplies. When 220 V power source is used, an 800 W power supply provides a maximum of 800 W power. When 110 V power source is used, an 800 W power supply provides a maximum of 400 W power.
- 2200 W PoE power supplies. When 220 V power source is used, a 2200 W power supply provides a maximum of 2200 W power. When 110 V power source is used, a 2200 W power supply provides a maximum of 1100 W power.



NOTE

The 2200 W power supply only provides PoE power, but does not provide power for the entire device.
 When the input voltage for an S7703 is 110 V, confirm with Huawei technical personnel to determine the power supply configuration.

3.1.2 Power Supply Principle

Figure 3-4 shows the principle of the DC power supplies on the S7700. Figure 3-5 shows the principle of the AC power supplies.

Figure 3-4 Principle of the DC power supplies on the S7700

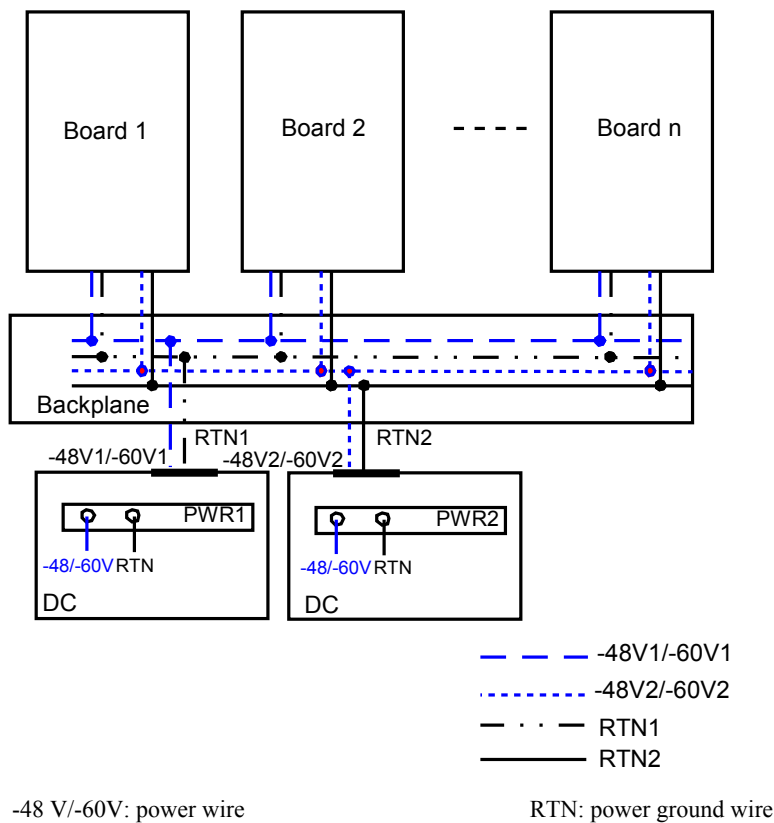
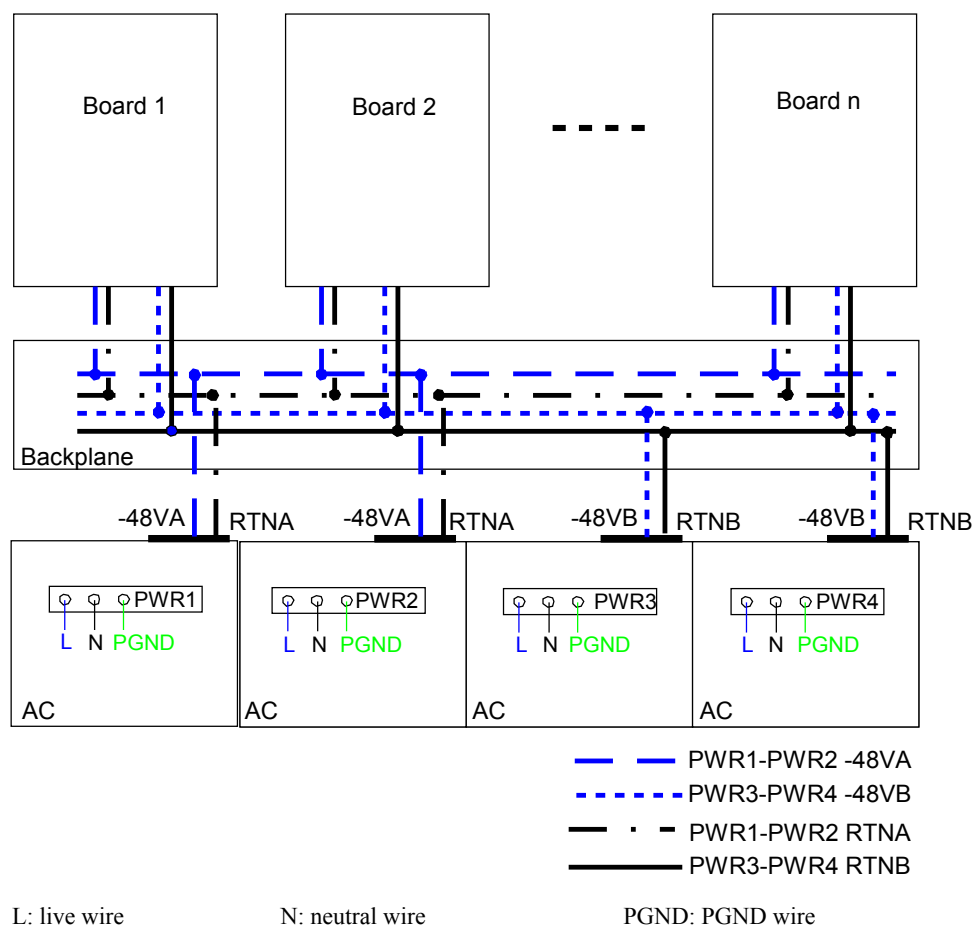

Figure 3-5 Principle of the AC power supplies on the S7700



3.2 1600 W DC Power Supply

This section describes the panel, functions, and technical specifications of 1600 W DC power supplies on the S7700.

3.2.1 Function Overview

The 1600 W DC power supply provides output of -48 V or -60 V. It provides the following functions:

- EMC filtering, lightning proof, and short circuit protection.
- Various alarms, for example, no-input alarm, air breaker off alarm, invalid lightning-proof alarm, and input undervoltage alarm.

3.2.2 Appearance and Panel

The power supplies are installed at the bottom of a chassis and are used for power input and power distribution.

A -48 V or -60 V DC power supply uses the standard structure. [Figure 3-6](#) shows the appearance of a 1600 W DC power supply on an S7700.

Figure 3-6 Appearance of a 1600 W DC power supply

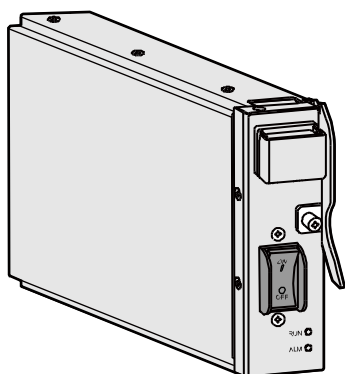
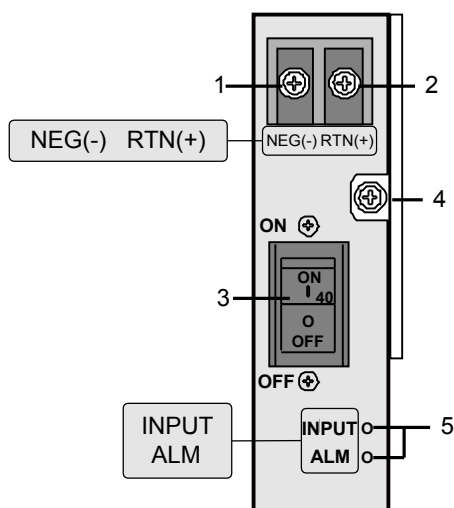

Figure 3-7 shows the panel of a 1600 W DC power supply.

Figure 3-7 Panel of a 1600 W DC power supply



- | | | |
|-----------|--------------|-----------|
| 1. NEG | 2. RTN | 3. Switch |
| 4. Handle | 5. Indicator | |

The indicators of the power supplies are shown on the panel through the light pipe. **Table 3-1** describes the indicators on a 1600 W DC power supply panel.

Table 3-1 Indicators on a 1600 W DC power supply

Indicator	Color	Description
ALM	Red	If the indicator is on, the protection circuit fails. If the indicator is off, the protection circuit is working properly.

Indicator	Color	Description
INPUT	Green	If the indicator is on, the -48 V power input is in the allowed range. If the indicator is off, the -48 V power input is unavailable.

 **NOTE**

- If the DC power supply is switched on, the DC power supply is working.
- If the DC power supply is switched off, the DC power supply is not working.

Table 3-2 describes the relationship between 1600 W DC power input cables and terminals.

Table 3-2 Relationship between 1600 W DC power input cables and terminals

Terminal Identifier	Cable	Cable Color	Connected Terminal
RTN	Power ground cable	Black	OT crimp terminal
NEG	Power cable	Blue	
NOTE RTN: Return			

3.2.3 Technical Specifications

Table 3-3 describes the technical specifications of the 1600 W DC power supply.

Table 3-3 Technical specifications of the 1600 W DC power supply

Item	Specification
Dimensions (W x D x H)	41 mm x 393 mm x 130 mm
Input rated voltage	-48 V/-60V DC
Output voltage	-48 V:-38.4V to -57.6V DC -60V:-48 V to -72V DC
Output current	40 A
Maximum input current	40 A
Maximum output power	1600 W

3.3 800 W AC Power Supply

This section describes the appearance, panel, functions, and technical specifications of an 800 W AC power supply on the S7700.

3.3.1 Function Overview

The 220V AC power supply provides 800W power and the 110V power supply provides 400W power. In addition, the AC power supply supports EMC filtering and provides the following functions:

- Output over-current
- Output over-voltage
- Output under-voltage
- Input over-voltage
- Input under-voltage
- Over-temperature
- Short circuit
- Surge protection

3.3.2 Appearance and Panel

An 800 W AC power supply uses the standard structure with a height of 3 U. [Figure 3-8](#) shows the appearance of an 800 W AC power supply on an S7700.

Figure 3-8 Appearance of an 800 W AC power supply

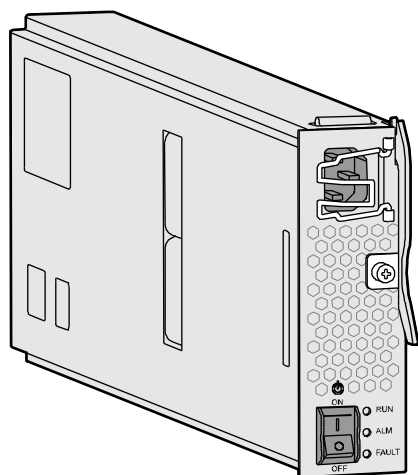

[Figure 3-9](#) shows the panel of an 800 W AC power supply.

Figure 3-9 Panel of an 800 W AC power supply

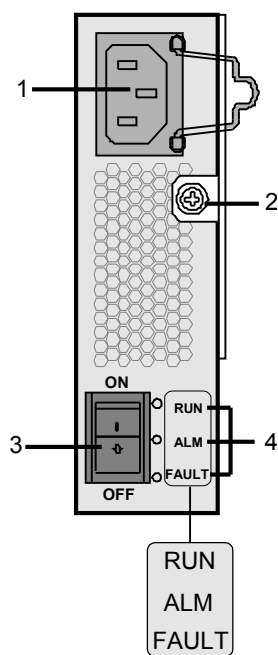

1. Power input

2. Handle

3. Switch

4. Indicator

Table 3-4 describes the indicators on an 800 W AC power supply panel.

Table 3-4 Indicators on an 800 W AC power supply panel

Indicator	Color	Description
RUN	Green	<p>If the indicator is on, the AC power input is in the allowed range.</p> <p>If the indicator is off and the FAULT indicator or ALM indicator is on, a fault has occurred or an alarm other than the overcurrent alarm is generated.</p>
ALM	Yellow	<p>If the indicator is on, a PS-off alarm, overtemperature alarm, overvoltage alarm, undervoltage alarm, or overcurrent alarm is generated.</p> <p>If the indicator blinks, communication with the monitoring device MPU or CMU is interrupted.</p> <p>If the indicator is off, the power supply is working properly.</p>
FAULT	Red	<p>If the indicator is on, the power supply has a fault that cannot be rectified.</p> <p>If the indicator is off, the power supply has no such fault.</p>

3.3.3 Technical Specifications

Table 3-5 describes the technical specifications of the 800 W AC power supply.

Table 3-5 Technical specifications of the 800 W AC power supply

Item	Specification
Dimensions (W x D x H)	41 mm x 393 mm x 130 mm
Weight	< 2.5 kg
Input rated voltage	220 V AC/110 V AC; 50/60 Hz
Rated input voltage range	200 V AC to 240 V AC (220 V AC input)/100 V AC to 120 V AC(110 V AC input); 47 Hz to 63 Hz
Maximum input voltage range	90 V AC to 290 V AC ; 47 Hz to 63 Hz(The output power is half of the maximum power when the input voltage is in the range of 90 V AC to 175 V AC.)
Maximum input current	5 A
Maximum output current	15 A (220 V AC input)/7.5 A (110 V AC input)
Maximum output power	800 W (220 V AC input)/400 W (110 V AC input)

3.4 2200 W AC Power Supply

This section describes the appearance, panel, functions, and technical specifications of the 2200 W AC power supply.

3.4.1 Function Overview

The 220 V power supply provides 2200 W power and the 110 V power supply provides 1100 W power. In addition, the AC power supply supports EMC filtering and provides protection against:

- Output overcurrent
- Output overvoltage
- Output short circuit
- Output undervoltage
- Input overvoltage
- Input undervoltage
- Overtemperature
- Short circuit
- Lightning

3.4.2 Appearance and Panel

A 2200 W AC power supply is 3 U high. **Figure 3-10** shows the appearance of a 2200 W AC power supply.

Figure 3-10 Appearance of a 2200 W AC power supply

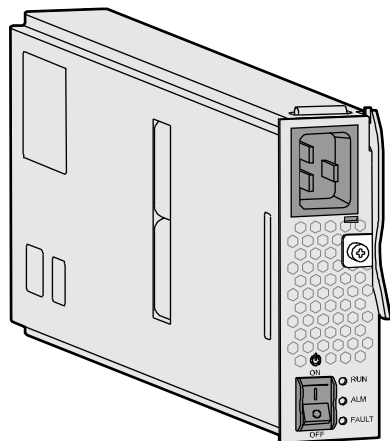
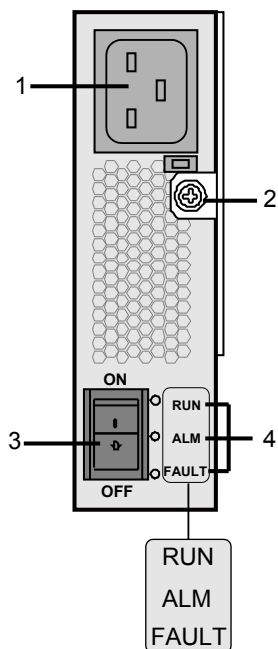

Figure 3-11 shows a 2200 W AC power supply panel.

Figure 3-11 Panel of a 2200 W AC power supply



1. Power input

2. Handle

3. Switch

4. Indicator

Table 3-6 describes the indicators on a 2200 W AC power supply panel.

Table 3-6 Indicators on an AC power supply panel

Indicator	Color	Description
RUN	Green	If the indicator is on, the AC power input is in the allowed range. If the indicator is off and the FAULT indicator or ALM indicator is on, a fault has occurred or an alarm other than the overcurrent alarm is generated.
ALM	Yellow	If the indicator is on, a PS-off alarm, overtemperature alarm, overvoltage alarm, undervoltage alarm, or overcurrent alarm is generated. If the indicator blinks, communication with the monitoring device MPU or CMU is interrupted. If the indicator is off, the power supply is working properly.
FAULT	Red	If the indicator is on, the power supply has a fault that cannot be rectified. If the indicator is off, the power supply has no such fault.

3.4.3 Technical Specifications

Table 3-7 describes the technical specifications of the 2200 W AC power supply.

Table 3-7 Technical specifications of the AC power supply

Item	Specification
Dimensions(W x D x H)	41 mm x 393 mm x 130 mm
Weight	< 6.0 kg
Rated input voltage	220 V AC/110 V AC; 50/60 Hz
Rated input voltage range	200 V AC to 240 V AC(220 V AC input)/100 V AC to 120 V AC(110 V AC input); 47 to 63 Hz
Maximum input voltage range	90 V AC to 290 V AC; 47 to 63 Hz(The output power is half of the maximum power when the input voltage is in the range of 90 V AC to 175 V AC.)
Maximum input current	15.5 A
Maximum output current	42 A(220 V AC input)/21 A(110 V AC input)
Maximum output power	2200 W(220 V AC input)/1100 W(110 V AC input)

4 Heat Dissipation System

About This Chapter

This chapter describes the heat dissipation system of the S7700, including fans and air filters.

[4.1 Introduction](#)

This section provides an overview of the heat dissipation system of the S7700.

[4.2 Fan Module](#)

This section describes the constitutions, panel and function of the fan module.

[4.3 Air Filter](#)

This section describes the air filters of the S7700.

4.1 Introduction

This section provides an overview of the heat dissipation system of the S7700.

4.1.1 Heat Dissipation System of the S7712

The heat dissipation system ensures that the S7712 operates in the normal temperature. For the temperature requirements, see Physical Specifications.

Figure 4-1 shows the airflow in the S7712.

Figure 4-1 Airflow in the S7712

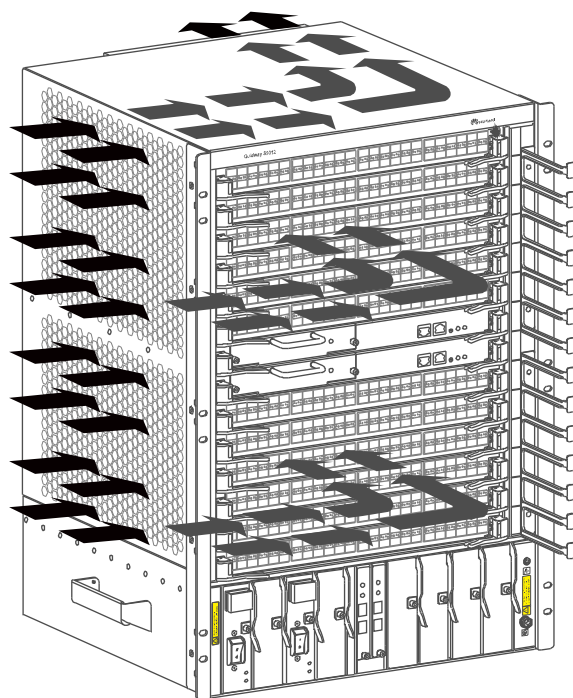

4.1.2 Heat Dissipation System of the S7706

The heat dissipation system ensures that the S7706 operates in the normal temperature. For the temperature requirements, see Physical Specifications.

Figure 4-2 shows the airflow in the S7706.

Figure 4-2 Airflow in the S7706

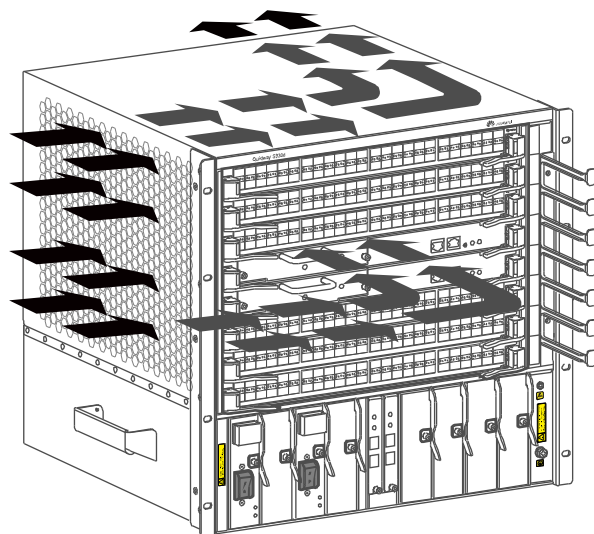

4.1.3 Heat Dissipation System of the S7703

The heat dissipation system ensures that the S7703 operates in the normal temperature. For the temperature requirements, see Physical Specifications.

Figure 4-3 shows the airflow in the S7703.

Figure 4-3 Airflow in the S7703

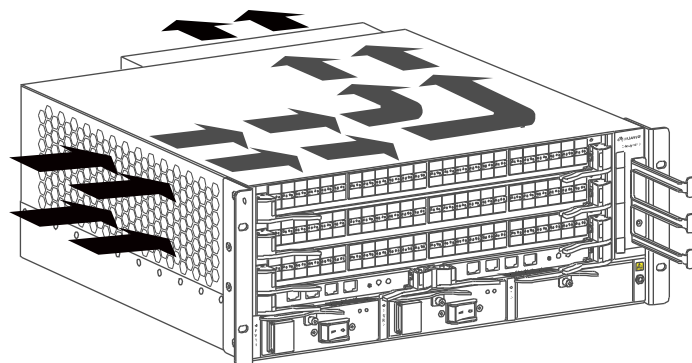

4.2 Fan Module

This section describes the constitutions, panel and function of the fan module.

4.2.1 Function Overview

The heat dissipation system of the S7700 is divided into several zones, and the fan speed can be dynamically adjusted.

 **CAUTION**

When a fan on the S7700 is faulty, a trap is reported. If all fans are faulty, shut down the device.

The S7700 uses modular fan modules. The numbers of fans used by different switch models are different. Installed at the rear of the chassis, the fan modules are used to cool down the S7700. The fan modules are hot swappable and interchangeable.

Each S7700 fan module serves a zone in the chassis and uses the intelligent fan-speed adjustment technology. The fan module monitors the temperature of key components and controls the temperature in each zone. If a component overheats, the fan speed increases. When the temperature falls within the allowed range, the fan speed decreases. The fan modules improve system reliability and reduce power consumption and noise.

Heat Dissipation Zones

The heat dissipation systems of S7706 and S7712 are divided into multiple zones. If there are empty slots in a zone, the fans corresponding to this zone operate at a low speed, reducing power consumption and noise.

As shown in [Figure 4-4](#), the S7706 has two fan modules, serving two zones. Each zone contains four boards.

Figure 4-4 S7706 heat dissipation zones

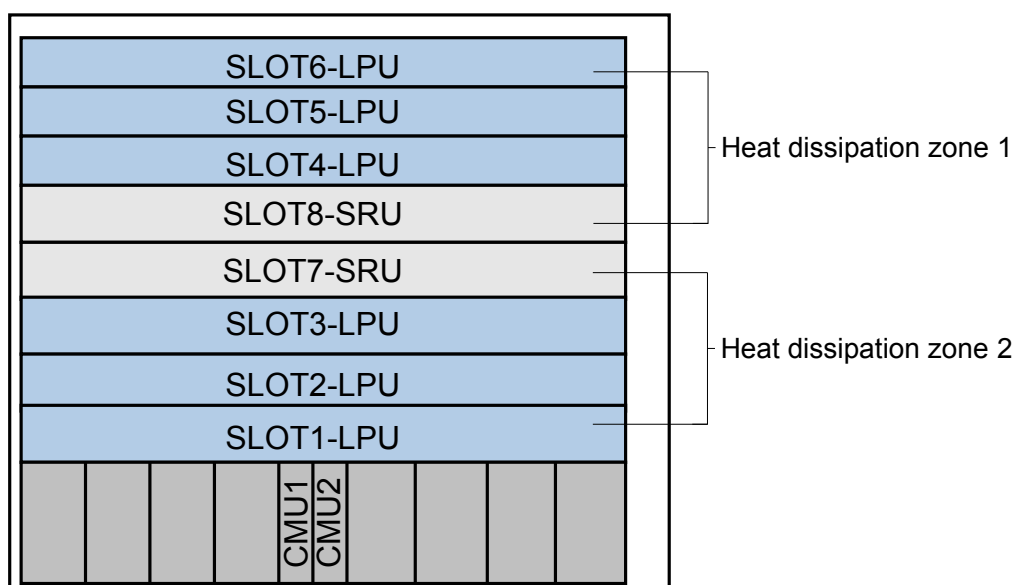

As shown in [Figure 4-5](#), the S7712 has four fan modules, serving four zones. Each zone contains four boards. The boards in slots 4 and 9 belong to two zones.

Figure 4-5 S7712 heat dissipation zones

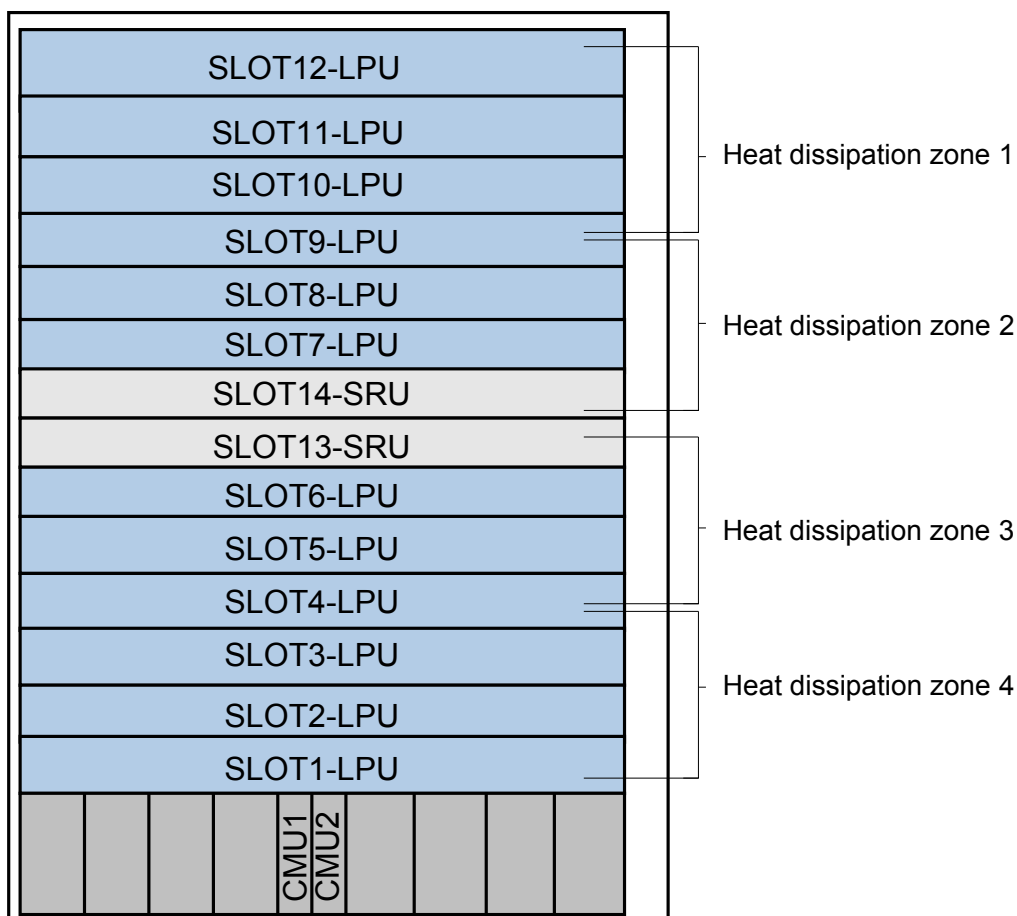

Dynamic Fan-Speed Adjustment

The S7700 supports intelligent fan speed adjustment. The system monitors temperature of key components. When the temperature of a component exceeds the preset value, the system increases the fan speed. When the temperature of all components falls below the preset value, the system reduces the fan speed. Intelligent fan speed adjustment ensures stable operation of the system and reduces power consumption and noises.

By default, the S7700 adjusts the fan speed based on the board temperature. You can configure the S7700 to adjust the fan speed according to the board temperature and optical module temperature. When the temperature limit is exceeded, the S7700 increases the fan speed. For example, when the board temperature decreases, but the optical module temperature increases, the S7700 increases the fan speed.

4.2.2 Panel

The fan module consists of the fan frame, dual fans, and fan control board (FCB).

Figure 4-6 shows the panel of the fan module on an S7700.

Figure 4-6 Panel of a fan module

Table 4-1 describes indicators on a fan module panel.

Table 4-1 Indicators on a fan module

Indicator	Color	Description
RUN/ALM	Green	If the indicator blinks (0.5 Hz), the fan module is working properly, and the communication is normal. If the indicator blinks (4 Hz), the fan module is working properly, but the communication is abnormal.
	Red	If the indicator blinks (0.5 Hz), an alarm is generated, but you cannot determine whether the fan module needs to be replaced. It is recommended that you observe the situation for a period of time. If the indicator is steady red, the fan module is faulty and you need to replace it.

4.2.3 Technical Specifications of the Fan Modules on the S7700

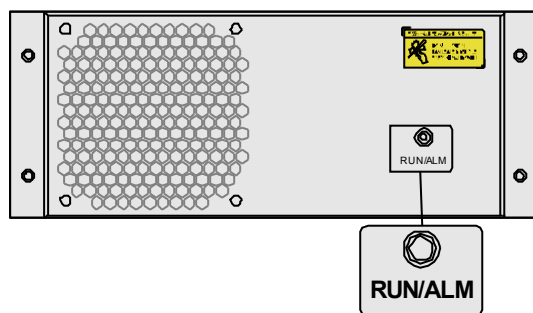
Table 4-2 shows the technical specifications of the fan modules on the S7700.

Table 4-2 Technical specifications of the fan module

Item	Specification
Dimensions (W x D x H)	323.9 mm x 74.8 mm x 126.6 mm
Weight	1140 ± 20 g
Maximum power consumption	31.6 W
Maximum wind pressure	319 Pa
Maximum air volume	163 CFM

Item	Specification
Maximum noise	62 dB
Operating voltage	-38.4 V DC to -72 V DC

4.3 Air Filter

This section describes the air filters of the S7700.

4.3.1 Air Filter of the S7712

On the S7712, air filters are separated from fan trays. Each S7712 switch requires two air filters of the same type, which are installed from rear of the switch. [Figure 4-7](#) shows an air filter.

Figure 4-7 S7712 air filter

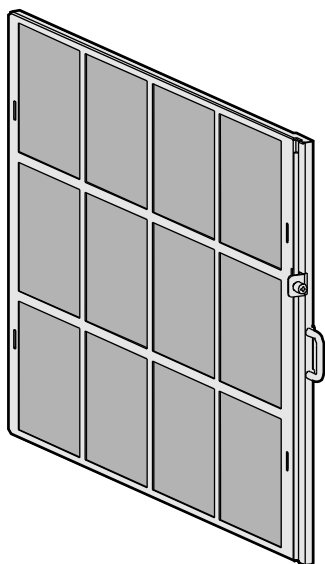

The air filters can be removed. For the method of removing and installing the air filters, see Precautions for Replacing Air Filters in the *S7700 Smart Routing Switch Parts Replacement*.

4.3.2 Air Filter of the S7706

On the S7706, the air filter is separated from fan trays. Each S7706 switch requires one air filter, which is installed from rear of the switch. [Figure 4-8](#) shows an air filter.

Figure 4-8 S7706 air filter

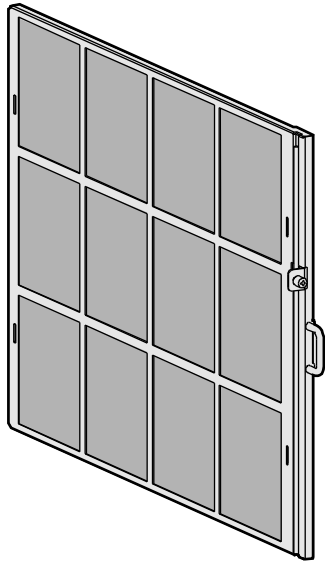

The air filter can be removed. For the method of removing and installing the air filter, see Precautions for Replacing Air Filters in the *S7700 Smart Routing Switch Parts Replacement*.

4.3.3 Air Filter of the S7703

On the S7703, the air filter is separated from fan trays. Each S7703 switch requires one air filter, which is installed from rear of the switch. [Figure 4-9](#) shows an air filter.

Figure 4-9 S7703 air filter

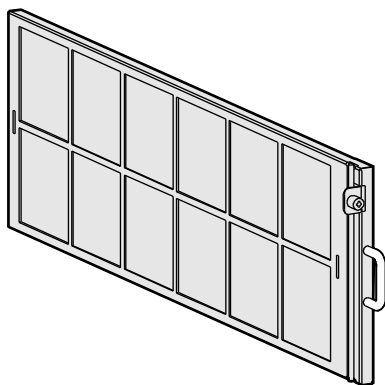

The air filter can be removed. For the method of removing and installing the air filter, see Precautions for Replacing Air Filters in the *S7700 Smart Routing Switch Parts Replacement*.

5 Boards

About This Chapter

This chapter describes the boards supported by the S7700.

[5.1 Introduction](#)

This section provides an overview of the boards supported by the S7700, including board classification, slot distribution, relation between boards, board appearances, and interfaces on each board.

[5.2 SRU-Main Control Unit](#)

The SRU is the main control unit of the S7706 and S7712.

[5.3 MCUA-Main Control Unit](#)

The MCUA is the main control unit of the S7703.

[5.4 FSUA - Enhanced Flexible Service Unit](#)

The FSUA is an optional and pluggable unit installed on the SRU to enhance the functions of the SRU.

[5.5 VSTSA - Stacking Card on the Main Control Board](#)

This section describes the stacking card, including the functions and features, applicable devices, slots, panel, indicators, interfaces, and technical specifications.

[5.6 CMU - Centralized Monitoring Unit](#)

The CMU manages the power supplies and fans of the system uniformly.

[5.7 SPU - VAMPA VAS Board](#)

This section describes the VAMPA value-added service (VAS) board, including the appearance, functions and features, applicable devices, slots, panel, indicators, interfaces, and technical specifications.

[5.8 G48S - 48-Port 100/1000BASE-X Interface Card \(SFP\)](#)

This section describes the 48-Port 100/1000BASE-X Interface Card (EA, SFP), 48-Port 100/1000BASE-X Interface Card (EC, SFP), 48-Port 100/1000BASE-X Interface Card (ED, SFP) and 48-Port 100/1000BASE-X Interface Card (FA, SFP), including the appearance, functions and features, panel, interface attributes, and technical specifications.

[5.9 G48T - 48-Port 10/100/1000BASE-T Interface Card \(RJ45\)](#)

This section describes the 48-Port 100/1000BASE-T Interface Card (EA, RJ45), 48-Port 10/100/1000BASE-T Interface Card (EC, RJ45) and 48-Port 1000BASE-T Interface Card (FA, RJ45), including the appearance, functions and features, panel, and technical specifications.

[5.10 G48VA - 48-Port 10/100/1000BASE-T PoE Interface Card\(EA,RJ45,PoE\)](#)

This section describes the 48-Port 10/100/1000BASE-T PoE Interface Card, including the appearance, functions and features, applicable device, slot, panel, indicators, interfaces, and technical specifications.

[5.11 G48CEAT - 36-Port 10/100/1000BASE-T and 12-Port 100/1000BASE-X Interface Card \(EA, RJ45/SFP\)](#)

This section describes the 36-Port 10/100/1000BASE-T and 12-Port 100/1000BASE-X Interface Card(EA,RJ45/SFP), including the appearance, functions and features, applicable devices, slots, panel, indicators, interfaces, and technical specifications.

[5.12 F48T - 48-Port 10/100BASE-T Interface Card \(RJ45\)](#)

This section describes the 48-Port 10/100BASE-T Interface Card (EA, RJ45), 48-Port 10/100BASE-T Interface Card (EC, RJ45) and 48-Port 10/100BASE-T Interface Card (FA, RJ45) , including the appearance, functions and features, panel, and technical specifications.

[5.13 X40SFC-40-Port 10GE Optical Interface Card \(FC, SFP+\)](#)

This section describes the X40SFC-40-port 10GE optical interface card (FC, SFP+), including the functions and features, applicable device models and slots, panel, indicators, interface attributes, and technical specifications.

[5.14 X16SFC-16-Port 10GE Optical Interface Card \(FC, SFP+\)](#)

This section describes the X16SFC-16-port 10GE optical interface card (FC, SFP+), including the functions and features, applicable device models and slots, panel, indicators, interface attributes, and technical specifications.

[5.15 G24CA - 24-Port 100/1000BASE-X and 8-Port 10/100/1000BASE-T Interface Card \(SFP/RJ45\)](#)

This section describes the 24-Port 100/1000BASE-X and 8-Port 10/100/1000BASE-T Interface Card (SA, SFP/RJ45), including the appearance, functions and features, panel, interface attributes, and technical specifications.

[5.16 S24XA-24-Port 100M/1000M Ethernet Optical Interface + 2-Port 10GE Optical Interface Line Card \(EA, SFP/XFP\)](#)

This section describes the 24-port 100/1000BASE-X and 2-port 10GBASE-X interface line card (EA, SFP/XFP), including the appearance, functions and features, panel, interface attributes, and technical specifications.

[5.17 T24XA - 24-Port 10/100/1000BASE-T and 2-Port 10GBASE-X Interface Card\(EA,RJ45/XFP\)](#)

This section describes the 24-Port 10/100/1000BASE-T and 2-Port 10GBASE-X Interface Card (EA,RJ45/XFP), including the appearance, functions and features, panel, interface attributes, and technical specifications.

[5.18 G24S - 24-Port 100/1000BASE-X Interface Card \(SFP\)](#)

This section describes the 24-Port 100/1000BASE-X Interface Card (SFP), including the appearance, functions and features, panel, interface attributes, and technical specifications.

[5.19 G24TFA-24-Port 10/100/1000BASE-T Interface Card\(FA,RJ45\)](#)

This section describes the 24-Port 10/100/1000BASE-T Interface Card(FA,RJ45), including the appearance, functions and features, panel, interface attributes, and technical specifications.

[5.20 X12SA - 12-Port 10GE Optical Interface Card \(SA, SFP+\)](#)

This section describes the 12-port 10GE optical interface card (SA, SFP+), including the appearance, functions and features, applicable device, slot, panel, indicators, interfaces, and technical specifications.

[5.21 X4UX - 4-Port 10GBASE-X Interface Card \(XFP\)](#)

This section describes the 4-Port 10GBASE-X Interface Card (EA, XFP) and 4-Port 10GBASE-X Interface Card (EC, XFP), including the appearance, functions and features, panel, interface attributes, and technical specifications.

[5.22 X2UX - 2-Port 10GBASE-X Interface Card \(XFP\)](#)

This section describes the 2-Port 10GBASE-X Interface Card (EA, XFP) and 2-Port 10GBASE-X Interface Card (EC, XFP), including the appearance, functions and features, panel, interface attributes, and technical specifications.

5.1 Introduction

This section provides an overview of the boards supported by the S7700, including board classification, slot distribution, relation between boards, board appearances, and interfaces on each board.

5.1.1 Board Classification

The S7700 supports main control boards and line processing units (LPUs). The S7712 and S7706 use SRUs as MPUs, and the S7703 uses MCUs as MPUs.

Table 5-1 lists the names, types, and description of boards on an S7700.

Table 5-1 Boards supported by the S7700

Type	Name	Description
SRU	SRUA	Main control board applied to the S7712 and S7706. The unidirectional switching capacity is 192 Gbit/s.
	SRUB	Main control board applied to the S7712 and S7706. The unidirectional switching capacity is 384 Gbit/s.
MCU	MCUA	Main control board applied to the S7703.
CMU	CMUA	Centralized monitoring unit, used to monitor the operation on the S7712 and S7706 and provide two interfaces: RS485 and MON.
SPU	VAMPA	Value-added service (VAS) board.
FSU	FSUA	Flexible service subcard on an SRU, enhancing service processing capability on the SRU.
VSU	VSTSA	Stack interface flexible pluggable card on the SRU, used to provide the switch stacking function.

Type	Name	Description
LPU	<ul style="list-style-type: none"> ● G24CA ● G48SA ● G48SC ● G48SD ● G48SFA ● G48TA ● G48TC ● G48TFA ● G48VA ● G48CEAT ● F48TA ● F48TC ● F48TFA ● S24XA ● T24XA ● G24SA ● G24SC ● G24TFA ● X4UXA ● X4UXC ● X2UXA ● X2UXC ● X4UXD ● X12SA ● X40SFC ● X16SFC 	<p>NOTE</p> <p>LPUs are classified into S series boards, E series boards, F series boards:</p> <ul style="list-style-type: none"> ● S series boards are SA boards, for example, 24-port 100M/1000M Ethernet optical LPU (SA, SFP)-32K MAC address entries. ● E series boards include EA, EC, and ED boards, for example, 48-port 100M Ethernet optical LPU (EA, SFP)-32K MAC address entries. ● F series boards include FA and FC boards, for example, 48-port 1000M Ethernet electrical LPU (FA, RJ45)-32K MAC address entries. <p>For LPU names, see 8.1 Boards Supported by the S7700.</p>

 **NOTE**

- GE electrical interfaces do not support the Ethernet synchronization function.
- The Small Form-Factor Pluggable (SFP) is a hot pluggable optical module.
- The 10 Gigabit Small Form-Factor Pluggable (XFP) is a 10G hot pluggable optical module.
- The 10 Gigabit Small Form-Factor Pluggable (SFP+) is a 10G hot pluggable optical module. Its caliber is smaller than the caliber of the XFP optical module.
- Except X12SA, all the cards have passed FCC certification.

5.1.2 Slot Distribution and Board Dimensions

Slots

Figure 5-1, Figure 5-2, and Figure 5-3 show the slots of the S7700.

Figure 5-1 Slots of the S7712

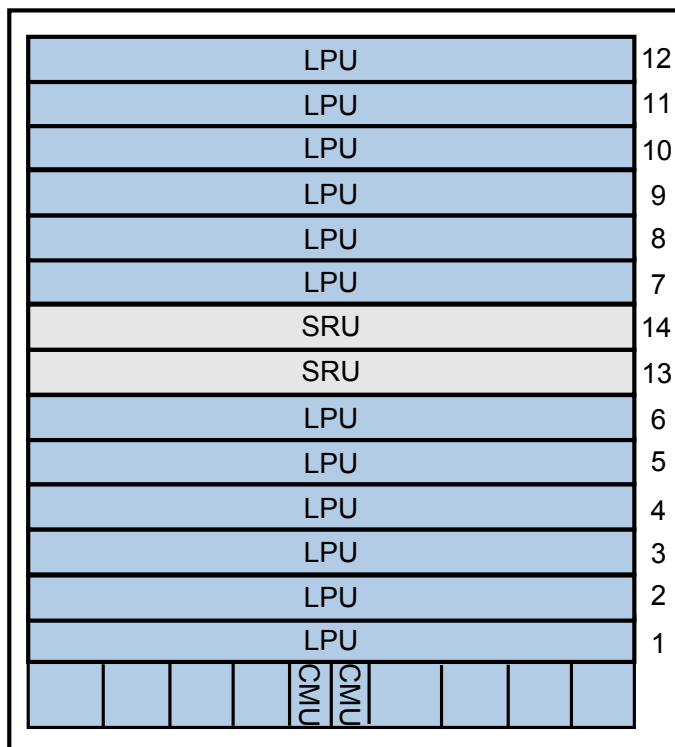

Figure 5-2 Slots of the S7706

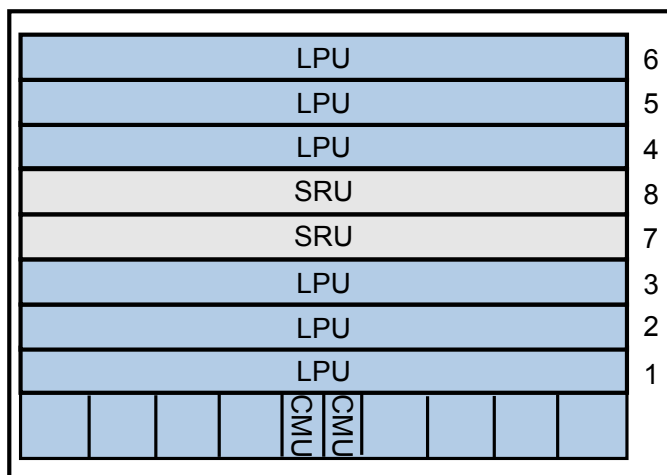

Figure 5-3 Slots of the S7703

Table 5-2, **Table 5-3**, and **Table 5-4** describe the slot distribution on the S7700.

Table 5-2 Slot distribution of the S7712

Slot	Quantity	Height	Note
1-12	12	35.1 mm	Slots for LPUs or SPUs
13, 14	2	35.1 mm	Slots for SRUs in 1+1 hot backup mode

Table 5-3 Slot distribution on the S7706

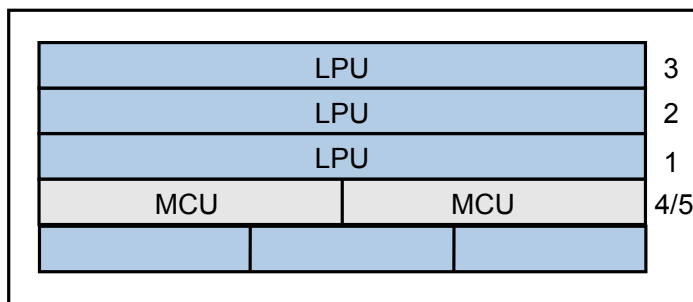
Slot	Quantity	Height	Note
1-6	6	35.1 mm	Slots for LPUs or SPUs
7, 8	2	35.1 mm	Slots for SRUs in 1+1 hot backup mode

Table 5-4 Slot distribution on the S7703

Slot	Quantity	Height	Note
1-3	3	35.1 mm	Slots for LPUs or SPUs
4, 5	2	19.8 mm	Slots for MCUs in 1+1 hot backup mode

Board Dimensions

Table 5-5 provides the dimensions of each board of the S7700. For the definitions of depth, width, and height of a board, see **Figure 5-4**.

Table 5-5 Board dimensions

Board Type	Dimensions (depth x width x height)
MCU	426.8 mm x 194.5 mm x 19.9 mm
SRU	426.8 mm x 394.7 mm x 35.1 mm
FSUor VSU	243.7 mm x 170.0 mm x 35.1 mm
CMU	412.7 mm x 112.9 mm x 19.8 mm
LPU	426.8 mm x 394.7 mm x 35.1 mm

Figure 5-4 Dimensions diagram

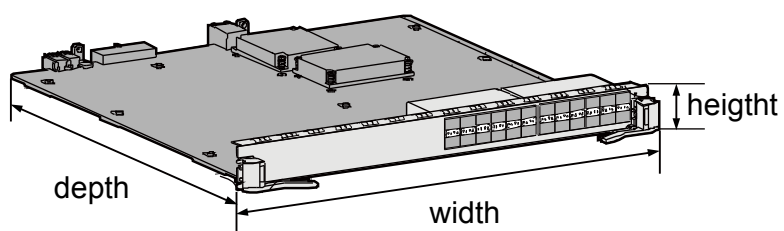

5.1.3 Relation Between Boards

Figure 5-5 and **Figure 5-6** show the relation between boards on the S7700.

Figure 5-5 Relation between boards on the S7712 and S7706

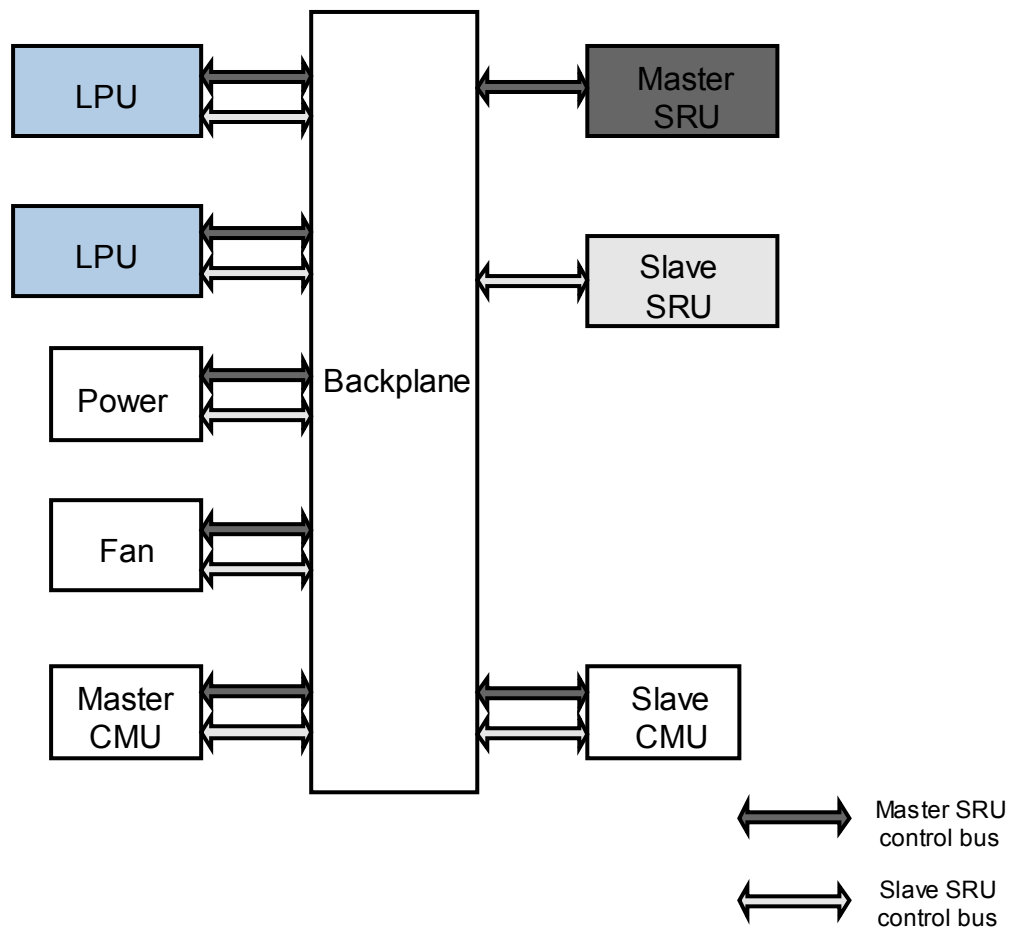
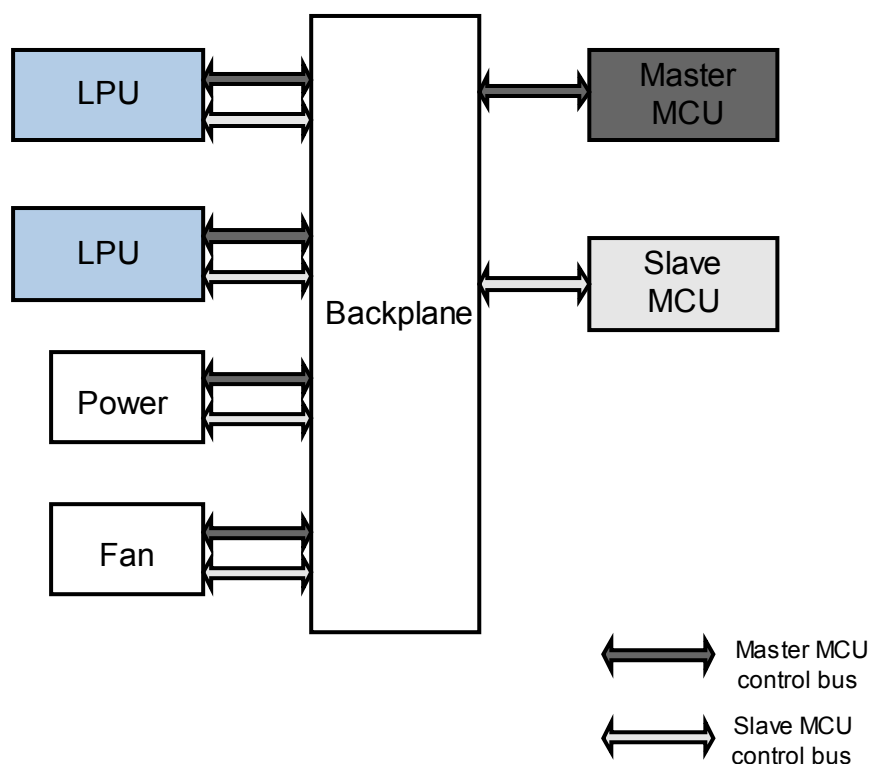

Figure 5-6 Relation between boards on the S7703



5.1.4 Interfaces on the Boards

All interfaces integrated on a board are accessible from the board panel. [Table 5-6](#) shows the distribution of interfaces on a board.

Table 5-6 Distribution of interfaces on boards

Interface Category	Interface Name	Interface Attribute	Type	Board
Optical interface	Ethernet optical interface	GE	LC/PC	G48SA
				G48SC
				G48SD
				G48SFA
				G48CEAT
				S24XA
				G24CA
				G24SA
				G24SC

Interface Category	Interface Name	Interface Attribute	Type	Board
		10GE	LC/PC	X40SFC X16SFC S24XA T24XA X4UXA X4UXC X2UXA X2UXC X4UXD
Electrical interface	Ethernet electrical interface	FE	RJ45	F48TA F48TC F48TFA
		GE	RJ45	G48CEAT G48TA G48TC G48TFA G48VA T24XA G24CA
Maintenance electrical interface	Ethernet interface ETH	10M/100M auto-sensing	RJ45	SRU MCUA
	Console interface	-	RJ45	SRU MCUA
Environment monitoring control interface	MON	-	RJ45	MCUA CMUA
Management interface of external PoE power supplies	RS485	-	RJ45	MCUA CMUA

 **NOTE**

- The VSTSA provides 16GE interfaces.

5.2 SRU-Main Control Unit

The SRU is the main control unit of the S7706 and S7712.

5.2.1 Introduction

The SRU is the control and switching platform of the S7712 and the S7706. It integrates the control unit, system clock unit, switching unit, and system maintenance unit. The SRU is the core component for system control and management. As the clock source and maintenance unit of the system, the SRU is the control plane and maintenance plane of the system.

The SRU has two models: SRUA and SRUB. The SRUA model has only one type: ES0D00SRUA00. The SRUB model has only one type: ES0D00SRUB00. [Table 5-7](#) lists the SRU models.

Table 5-7 SRU models

Name	Switching Capacity
ES0D00SRUA00	512 Gbit/s, bidirectional
ES0D00SRUB00	1 Tbit/s, bidirectional

5.2.2 Function and Application

Function

The SRU integrates the control and switching functions and provides the control plane, management plane, and switching plane.

- The control plane has such functions as protocol processing, service processing, route calculation, forwarding control, service scheduling, traffic statistics, and system security.
- The management plane is responsible for system monitoring, environment monitoring, log and alarm processing, system loading, and system upgrade.
- The switching plane provides high-speed and non-blocking data channels to implement service switching between service modules. The S7700 supports double SRUs in 1+1 hot backup with the data switching units working in load balancing, and supports flexible card.

Based on the functions, the SRU consists of the following modules physically:

- Control module: functions as the control and management plane for the SRU and the entire system, implementing protocol processing, route calculation, forwarding control, system management, and system security.
- Switching module: functions as the service switching plane, providing high-speed service channels to implement service switching.

- Local clock module: provides the working clock for the chips of the control module, switching module, and equipment management and monitoring module.
- Equipment management and monitoring module: provides the controller area network bus (CANBUS) module to monitor the SRU and manage the CANbus modules on the LPUs.
- Power supply: provides power supply for the SRU and FSU.
- FSU: provides enhanced services such as centralized forwarding, network quality analysis (NQA), Ethernet operation, administration and maintenance (OAM), and NetFlow. It is an optional value-added service module.
- Stacking card: enables two switches to form a stack. The stacking card is optional.

 **NOTE**

- The SRU stores the configuration data, startup files, upgrade software, and logs.
- The SRUs work in 1+1 hot backup.
- The SRUs are hot pluggable. Before removing the active SRU, perform the active/standby switchover first.
- The fans on a switch work in intelligent speed adjustment mode after an active/standby switchover occurs on the switch. If the fans run at a specified speed before a switchover, run the **set fan-speed** command after the switchover to set the fan speed again.

Application

The SRUs of the S7712 are installed in slot 13 and slot 14; the SRUs of the S7706 are horizontally installed in slot 7 and slot 8. The SRU slots are in the center of the subrack of the S7712 or S7706.

The S7712 or S7706 must have at least one SRU. You can install one or two SRUs. If only one SRU is installed, it can be installed in either of the SRU slots. To improve reliability of a key device, you can install double SRUs. When the master SRU fails, the slave SRU substitutes for the master SRU automatically to prevent service interruption.

 **NOTE**

The SRUA and SRUB cannot be installed on the same S7700.

5.2.3 Panel

[Figure 5-7](#) and [Figure 5-8](#) show the appearance of SRU panels.

Figure 5-7 Appearance of an ES0D00SRUA00 panel

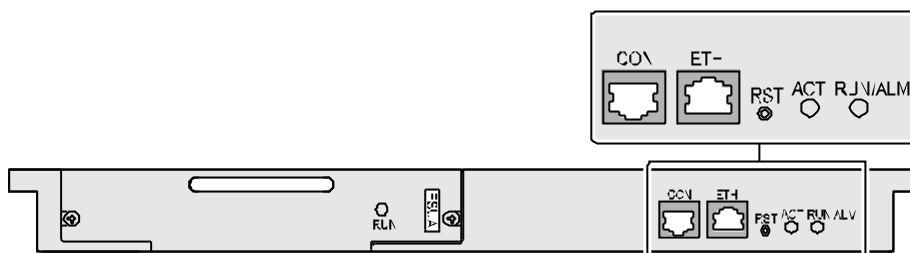
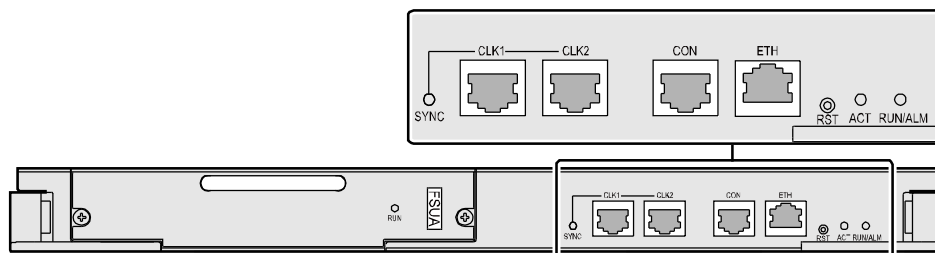

Figure 5-8 Appearance of an ES0D00SRUB00 panel

Buttons and Indicators on an SRU Panel

Table 5-8 describes the buttons and indicators on an SRU panel.

Table 5-8 Buttons and indicators on an SRU panel

Indicator/Button	Color	Description
RUN/ALM	Green	If the indicator is on, the SRU is powered on, but the software is not running. If the indicator blinks once every 2s (0.5 Hz), the system is running properly. If the indicator blinks once every 0.25s (4 Hz), the system is starting.
	Red	If the indicator is steady red, the SRU is faulty.
	Orange	If the indicator is steady orange, the SRU is installed, and the board is powered off.
ACT	Green	This indicator shows whether the SRU is the master SRU or slave SRU. If the indicator is on, the SRU is the master SRU. If the indicator is off, the SRU is the slave SRU.
RST	-	Press this button to reset the SRU. NOTE Resetting the SRU will cause the loss of service packets. Confirm the operation before you press the Reset button.
SYNC	Green	If the indicator is on, the device supports time and clock synchronization, and the clock board is installed on the SRU. If the indicator is off, the device supports time and clock synchronization, but the clock board is not installed on the SRU.

5.2.4 Interfaces

Table 5-9 describes the types and functions of the interfaces on the SRU.

Table 5-9 Types and functions of the interfaces on the SRU

Name	Quantity	Description
ETH (10M/100M Base-TX auto-sensing)	1	Used to connected to the network interface of the configuration terminal or the network management workstation. The configuration environment thus can be established on site or remotely.
Console interface	1	Used to connect to the console to implement on-site system configuration of the S7700.
BITS interface	2	The CLK1 and CLK2 interfaces on the SRU map the BITS0 and BITS1 interfaces of the clock board. The BITS interfaces are connected to the BITS device or connected to the BITS interfaces of other products to synchronize the time and clock.

5.2.5 Interface Attributes

The following tables describe the attributes of the interfaces on the SRU.

- **Table 5-10** describes the attributes of the 10M/100M Base-TX Ethernet interface.

Table 5-10 Attributes of the 10M/100M Base-TX Ethernet interface

Attribute	Description
Connector type	RJ45
Compliance standard	IEEE 802.3

- **Table 5-11** describes the attributes of the console interface.

Table 5-11 Attributes of the console interface

Attribute	Description
Connector type	RJ45
Operation mode	Full duplex Universal Asynchronous Receiver/Transmitter (UART)

Attribute	Description
Compliance standard	RS-232
Data equipment type	Data Circuit-terminating Equipment (DCE)

- [Table 5-12](#) describes the attributes of the BITS interfaces.

Table 5-12 Attributes of the BITS interfaces

Attribute	Description
Connector type	RJ45
Operation mode	Clock synchronization mode: full duplex Time synchronization mode: half duplex
Frame format	<ul style="list-style-type: none"> ● 1 pps + Time of Day (TOD) ● DC Level Shifter (DCLS) ● 2 MHz ● 2 Mbit/s: HDB3 code ● 1.544 Mbit/s: B8ZS code
Compliance standard	<ul style="list-style-type: none"> ● 1 pps + TOD <ul style="list-style-type: none"> - NMEA-0183 - TOD standard of China Mobile ● DCLS: standard of DCLS signals ● 2 MHz: G.703 standard ● 2 Mbit/s: G.703 standard ● 1.544 Mbit/s: G.703 standard
Cable	<p>Time synchronization mode: time synchronization network cable, which is a common straight-through network cable with the RS422 interface level</p> <p>Clock synchronization mode: E1/T1 cable, which is a balanced cable with an impedance of 120 ohms.</p> <p>For details about cable, refer to 6.7 Clock Cable.</p>

5.2.6 Technical Specifications

- [Table 5-13](#) describes the technical specifications of the SRU.

Table 5-13 Technical specifications of the SRU

Item	Specification
SRU dimensions (depth x width x height)	426.8 mm x 394.7 mm x 35.1 mm Space for the FSU or VSU: 243.7 mm x 170.0 mm x 35.1 mm
Maximum power consumption	ES0D00SRUA00: 81 W (including FSUA) ES0D00SRUB00: 105 W (including FSUA)
Weight	ES0D00SRUA00: 2.80 kg ES0D00SRUB00: 2.90 kg
Long-term temperature	0°C to 45°C
Short-term temperature	-5°C to 55°C

5.3 MCUA-Main Control Unit

The MCUA is the main control unit of the S7703.

5.3.1 Introduction

The MCUA is the control and switching platform of the S7703. It integrates the control unit, system clock unit, and system maintenance unit. The MCUA is the core component for system control and management. In addition, as the clock source and maintenance unit of the system, the MCUA is the control plane and maintenance plane of the system.

The S7700 supports only ES0D00MCUA00 as the MCUA.

5.3.2 Function and Application

Function Description

The MCUA of the S7703 has the following functions:

- Providing out-band communication channels between boards.
- Monitoring system operation: The MCUA collects operation data of different units periodically. According to the running status of the units, the MCUA generates the control information used to check availability of boards, control the running status of the switching fabric, perform port switching, reset the forwarding engine, and increase the fan speed.
- Working as the proxy of the network management module: The MCUA can manage and maintain the S7703 through the open management interfaces (serial interfaces or network interfaces).

- Implementing data configuration: The MCUA stores the configuration data, startup file, accounting data, upgrade software, and running logs of the S7703. The MCUA provides a CF card to store data files.
- Working in 1+1 hot backup mode to improve reliability: The master and slave MCUAs monitor the status of each other. When the master MCUA fails, the slave MCUA substitutes for the master MCUA to ensure normal running of the system.

 **NOTE**

The fans on a switch work in intelligent speed adjustment mode after an active/standby switchover occurs on the switch. If the fans run at a specified speed before a switchover, run the **set fan-speed** command after the switchover to set the fan speed again.

Application

The MCUAs of the S7703 are installed in slot 4 and slot 5.

The S7703 must have at least one MCUA. You can install one or two MCUAs. If only one MCUA is installed, it can be installed in either of the MCUA slots. To improve reliability of a key device, you can install double MCUAs. When the master MCUA fails, the slave MCUA substitutes for the master MCUA automatically to prevent service interruption.

5.3.3 Panel

[Figure 5-9](#) shows the appearance of the MCUA panel.

Figure 5-9 Appearance of the ES0D00MCUA00 panel

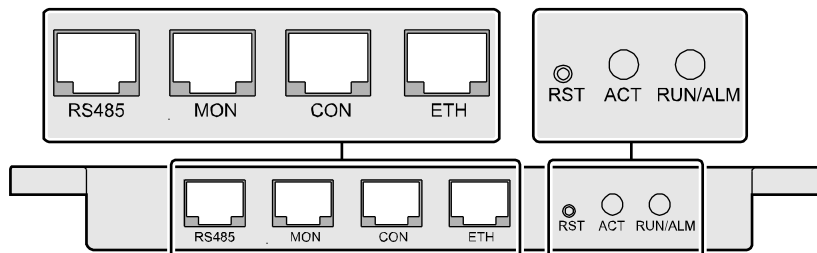

Buttons and Indicators on the Panel

[Table 5-14](#) describes the buttons and indicators on the MCUA panel.

Table 5-14 Description of the buttons and indicators on the MCUA panel

Indicator/Button	Color	Description
RUN/ALM	Green	If the indicator is on, it indicates that the MCUA is powered on, but the software is not running. If the indicator blinks every 2s (0.5 Hz), it indicates that the system is running normally. If the indicator blinks every 0.25s (4 Hz), it indicates that the system is starting.
	Red	If the indicator is in red, it indicates that the MCUA is faulty.
	Orange	If the indicator is in orange, it indicates that the MCUA is installed, and the board is powered off.
ACT	Green	This indicator shows whether the MCUA is the master MCUA or the slave MCUA. If the indicator is on, it indicates that the MCUA is the master MCUA. If the indicator is off, it indicates that the MCUA is the slave MCUA.
RST	-	Press this button to reset the board.

5.3.4 Interfaces

Table 5-15 describes the types and functions of the interfaces on an MCUA board.

Table 5-15 Types and functions of the interfaces on an MCUA board

Name	Quantity	Description
ETH (10M/100M Base-TX auto-sensing)	1	Used to connect to the network interface of the configuration terminal or the network management workstation. The configuration environment can be established onsite or remotely.
Console interface	1	Used to connect to the console interface to implement the onsite system configuration of the S7700.
MON interface	1	Used to control environment monitoring.
RS485 interface	1	Used to manage external PoE power supplies.

 **NOTE**

Currently, the S7700 does not support external PoE power supplies.

5.3.5 Interface Attributes

This section describes the attributes of the interfaces on the MCUA.

- **Table 5-16** describes the attributes of the 10M/100M Base-TX Ethernet interface.

Table 5-16 Attributes of the 10M/100M Base-TX Ethernet interface

Attribute	Description
Connector type	RJ45
Compliance standard	IEEE 802.3

- **Table 5-17** describes the attributes of the console interface.

Table 5-17 Attributes of the console interface

Attribute	Description
Connector type	RJ45
Operation mode	Full duplex Universal Asynchronous Receiver/Transmitter (UART)
Compliance standard	RS-232
Data equipment type	Data Circuit-terminating Equipment (DCE)

- **Table 5-18** describes the attributes of the RS485 interface.

Table 5-18 Attributes of the RS485 interface

Attribute	Specification
Connector type	RJ45
Compliance standard	RS-485

- **Table 5-19** describes the attributes of the MON interface.

Table 5-19 Attributes of the MON interface

Attribute	Specification
Connector type	RJ45
Compliance standard	RS-232

5.3.6 Technical Specifications

Table 5-20 describes the technical specifications of the MCUA.

Table 5-20 Technical specifications of the MCUA

Item	Specification
Board dimensions (depth x width x height)	426.8 mm x 194.5 mm x 19.9 mm
Maximum power consumption	LE0MMCUA: 18 W
Weight	0.90 kg
Long-term temperature	0°C to 45°C
Short-term temperature	-5°C to 55°C

5.4 FSUA - Enhanced Flexible Service Unit

The FSUA is an optional and pluggable unit installed on the SRU to enhance the functions of the SRU.

5.4.1 Introduction

The FSUA is installed on the SRU shown in **Figure 5-10**. The FSUA provides the features such as OAM, BFD and security.

The FSUA is an optional subcard on the SRU. It does not provide any interface.

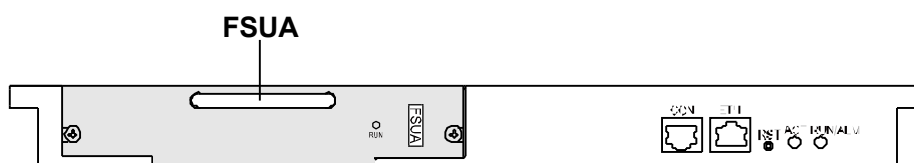
Figure 5-10 Position of FSU in SRU

5.4.2 Function and Application

Function

The FSUA provides the following functions:

- Enhancing Ethernet OAM and BFD
- Ensuring security of the CPU on the SRU and limiting the rate of packets sent to the CPU
- Storing and querying the board information

Application

The FSUA is installed on an SRU.

It is an optional subcard on the SRU of the S7712 and S7706, and can be removed and installed flexibly.

Users can choose to install an FSUA based on the service requirement, which improves service flexibility and expansibility.

 **NOTE**

To use an FSUA, install the FSUA on the master and slave SRUs.
The FSUA is not hot swappable.

5.4.3 Panel

[Figure 5-11](#) shows the appearance of the FSUA panel.

Figure 5-11 Appearance of the FSUA panel

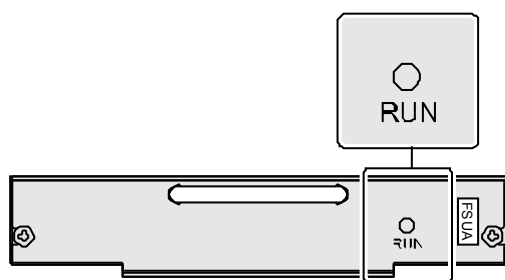

[Table 5-21](#) describes the buttons and indicators on the FSUA panel.

Table 5-21 Description of the buttons and indicators on the FSUA panel

Indicator/Button	Color	Description
RUN	Green	If the indicator is on, it indicates that the FSUA is installed and is powered on. If the indicator is off, it indicates that the FSUA is not installed.

5.4.4 Technical Specifications

Table 5-22 describes the technical specifications of the FSUA.

Table 5-22 Technical specifications of the FSUA

Item	Specification
Board dimensions (D x W x H)	243.7 mm x 170.0 mm x 35.1 mm
Maximum power consumption	20 W
Weight	0.42 kg
Long-term temperature	0°C to 45°C
Short-term temperature	-5°C to 55°C

5.5 VSTSA - Stacking Card on the Main Control Board

This section describes the stacking card, including the functions and features, applicable devices, slots, panel, indicators, interfaces, and technical specifications.

5.5.1 Introduction

The stacking card supported by the S7700 is called VSTSA. The VSTSA can be installed on the SRU of the S7706 or S7712 to provide switch stacking function.

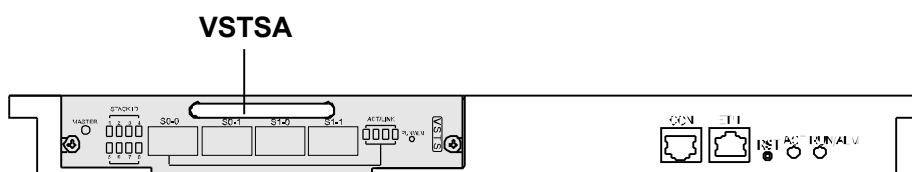
Figure 5-12 Position of VSTSA in SRU

5.5.2 Function and Application

Function

Each VSTSA stack card provides four 16G electrical or optical interfaces to implement data access and line-speed switching.

The switches connected using the interfaces on the VSTSA belong to a switching domain and are considered as one device. Users can manage all the switches in a stack on the master switch.

Application

A VSTSA can be installed on the SRU of the S7712 or S7706. To configure the stack, install the VSTSA on the SRU in the same chassis.

 **NOTE**

The VSTSA can be installed only on an SRUA or SRUB.

The FSUA and VSTSA are installed in the subcard slots of the SRUs but cannot be installed in the same chassis.

The VSTSA is not hot swappable.

5.5.3 Panel

[Figure 5-13](#) shows the appearance of the VSTSA panel.

Figure 5-13 Appearance of the VSTSA panel

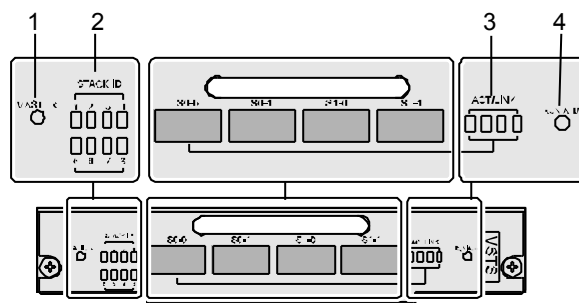

1. Master state indicator 2. Stack ID indicator 3. ACT/LINK indicator 4. RUN/ALM indicator

Buttons and Indicators on the Panel

[Table 5-23](#) describes the buttons and indicators on the VSTSA panel.

Table 5-23 Description of the buttons and indicators on the VSTSA panel

Indicator/Button	Color	Description
MASTER	Green	<p>If the indicator is on, it indicates that the SRU where the VSTSA is installed is the master in the stack.</p> <p>If the indicator is off, the SRU where the VSTSA is installed may be:</p> <ul style="list-style-type: none"> ● The standby SRU on the master switch ● The active SRU on the slave switch ● The standby SRU on the slave switch
STACK ID	Green	<p>This indicator shows the ID of the stack. Currently, a stack can contain up to two switches; therefore, only the indicators of stack 1 and stack 2 may be on.</p> <p>When both the two SRUs are installed with the VSTSA, the stack ID indicators must be the same. That is, the stack 1 indicators or stack 2 indicators are on.</p>
ACT/LINK	Green	<p>If the indicator is on, it indicates the state of link is UP.</p> <p>If the indicator is on, it indicates that the state of link is DOWN.</p>
RUN/ALM	Yellow	Steady on (both the red and green LEDs are on): The card is powered off.
	Green	Steady on: The card has been powered on and is running normally.

5.5.4 Interfaces

Table 5-24 describes the types and functions of the interfaces on the VSTSA.

Table 5-24 Types and functions of the interfaces on the VSTSA

Name	Quantity	Description
16G SR4 optical interfaces	4	The VSTSA card provides four 16Gbit/s optical interfaces to transmit and receive service packets.

The VSTSA card provides four interfaces: S0-0, S0-1, S1-0, and S1-1. The S7700 currently supports the stack of up to two switches. When S7700A and S7700B are connected through VSTSAs, the interfaces are connected as **Figure 5-14** shows.

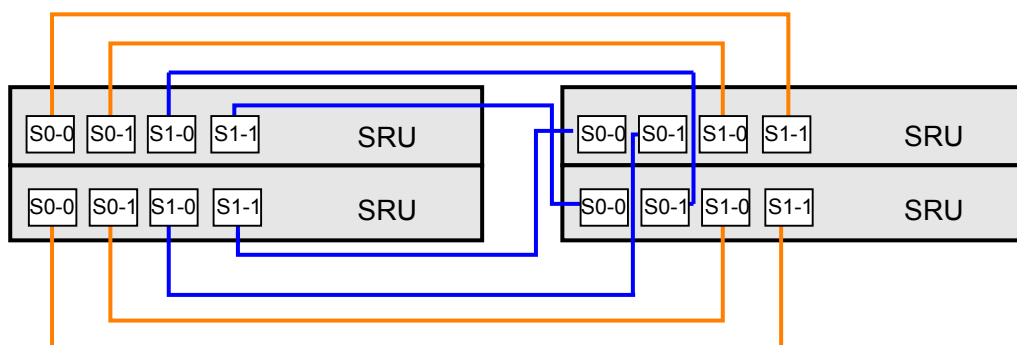
Figure 5-14 External cable connections of a stack

For details about stack cables, see [6.8 Stack Cables](#).

For details on how to select optical modules for optical stack interfaces, see [9.6 Attributes of a 40G Optical Module](#).

5.5.5 Technical Specifications

[Table 5-25](#) describes the technical specifications of the VSTSA.

Table 5-25 Technical specifications of the VSTSA

Item	Specification
Board dimensions (depth x width x height)	243.7 mm x 170.0 mm x 35.1 mm
Power consumption	12 W
Weight	1 kg
Long-term temperature	0°C to 45°C
Short-term temperature	-5°C to 55°C

5.6 CMU - Centralized Monitoring Unit

The CMU manages the power supplies and fans of the system uniformly.

5.6.1 Introduction

The CMU manages the power supplies and fans of the system uniformly.

The CMUs are installed in the right slots of PWR4, as shown in [Figure 5-15](#).

Figure 5-15 Position of the CMUs

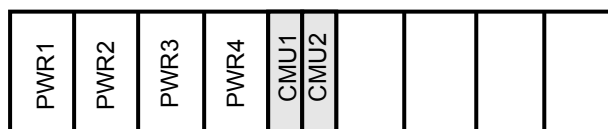

5.6.2 Function and Application

Function Description

The CMU consists of the following modules:

- Equipment management module: sends interface control signals for equipment management.
- Backplane interface module: sends all interface signals on the backplane to control the power supply, fans, and master/slave states of CMU.

Application

The CMU is applied to the S7712, or S7706. There are two CMU slots on the subrack: one for the master CMU and the other for the slave CMU. You can install one or two CMUs as required.

5.6.3 Panel

Figure 5-16 shows the appearance of the CMU panel.

Figure 5-16 Appearance of the CMU

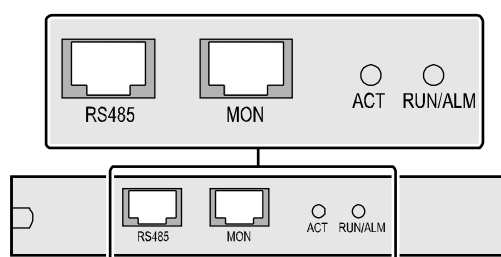

Buttons and Indicators on the Panel

Table 5-26 describes the buttons and indicators on the CMU panel.

Table 5-26 Description of the buttons and indicators on the CMU panel

Indicator/Button	Color	Description
RUN/ALM	Green	If the indicator blinks every 2s (0.5 Hz), it indicates that the system is running normally. If the indicator blinks every 0.25s (4 Hz), it indicates that the system is unregistered.
	Red	If the indicator is on, it indicates that the CMU is faulty. If the indicator blinks every 2s (0.5 Hz), it indicates that an alarm is generated because of a fault on the CMU, fans or power. If the indicator blinks every 0.25s (4 Hz), it indicates that the input power is insufficient.
ACT	Green	This indicator shows whether the CMU is master CMU or the slave CMU. If the indicator is on, it indicates that the CMU is the master CMU. If the indicator is off, it indicates that the CMU is the slave CMU.

5.6.4 Interfaces

Table 5-27 describes the types and functions of the interfaces on a CMU board.

Table 5-27 Types and functions of the interfaces on a CMU board

Name	Quantity	Description
MON interface	1	Used to control environment monitoring.
RS485 interface	1	Used to manage external PoE power supplies.

 **NOTE**

Currently, the S7700 does not support external PoE power supplies.

5.6.5 Interface Attributes

This section describes the attributes of the interfaces on the CMU.

- **Table 5-28** describes the attributes of the RS485 interface.

Table 5-28 Attributes of the RS485 interface

Attribute	Specification
Connector type	RJ45
Compliance standard	RS-485

- **Table 5-29** describes the attributes of the MON interface.

Table 5-29 Attributes of the MON interface

Attribute	Specification
Connector type	RJ45
Compliance standard	RS-232

5.6.6 Technical Specifications

Table 5-30 describes the technical specifications of the CMU.

Table 5-30 Technical specifications of the CMU

Item	Specification
Board dimensions (depth x width x height)	412.7 mm x 112.9 mm x 19.8 mm
Maximum power consumption	1 W
Weight	0.22 kg
Long-term temperature	0°C to 45°C
Short-term temperature	-5°C to 55°C

5.7 SPU - VAMPA VAS Board

This section describes the VAMPA value-added service (VAS) board, including the appearance, functions and features, applicable devices, slots, panel, indicators, interfaces, and technical specifications.

5.7.1 Introduction

Functioning as the value-added service (VAS) board of the S7700, the Service Process Unit (SPU) provides service functions such as load balancing, firewalls, Network Address Translation (NAT), IP Security (IPSec), and NetStream, thus meeting requirements of different application scenarios for diverse industry networks.

Currently, the SPU supports only one board, namely, VAMPA.

5.7.2 Function and Application

Function

The system transmits the packets to be processed to the SPU. Then the SPU processes the packets related to the VASs. The SPU is applicable to load balancing, NAT, firewall, IPSec, and NetStream solutions.

Application

A VAMPA can be installed in any LPU slot of the S7712, S7706, or S7703.

5.7.3 Panel

Currently, the SPU supports only the VAMPA.

The VAMPA is installed horizontally. A serial interface (identified as CON) and an FE electrical interface (identified as ETH) are located on the panel. [Figure 5-17](#) shows the panel.

Figure 5-17 VAMPA panel

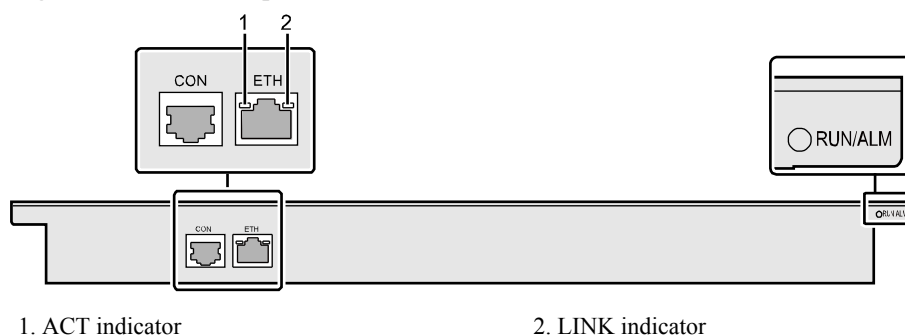

The board indicator RUN/ALM and interface indicators ACT and LINK are located on the VAMPA panel. [Table 5-31](#) describes the colors and blinking states of the indicators.

Table 5-31 Buttons and indicators on the VAMPA panel

Indicator/Button	Color	Description
RUN/ALM	Green	If the indicator is on, it indicates that the board is powered on but the software is not running. If the indicator blinks slowly (0.5 Hz), it indicates that the system runs normally. If the indicator blinks quickly (4 Hz), it indicates that the system is being started.
	Red	If the indicator is on, it indicates that the board is faulty.
	Orange	If the indicator is on, it indicates that the board is Steady on (both the red and green LEDs are on): installed in the slot and is powered off..
ACT	Amber	If the indicator blinks, it indicates that data is being transmitted or received. If the indicator is off, it indicates that no data is being transmitted or received.
LINK	Green-yellow	If the indicator is on, it indicates that the link is connected. If the indicator is off, it indicates that the link is blocked.

5.7.4 Interfaces

Table 5-32 describes types and functions of interfaces on the VAMPA.

Table 5-32 Interfaces on the VAMPA and their functions

Interface	Quantity	Description
Console interface	1	Provides a serial interface. A user can log in to the local SPU by connecting the serial interface on the host and the console interface on the SPU through a cable to configure the SPU locally.
Ethernet interface	1	Provides an FE electrical interface. A user can log in to the SPU through Telnet to configure the SPU.

5.7.5 Interface Attributes

This topic describes connector types, attributes, operation modes, and compliance standards of the interfaces on the panel.

Table 5-33 and **Table 5-34** describe attributes of the interfaces on the panel.

Table 5-33 Serial interface attributes

Attribute	Description
Connector type	RJ45
Interface attribute	RS232
Compliance standard	EIA/TIA-232

Table 5-34 Ethernet interface attributes

Attribute	Description
Connector type	RJ45
Interface attribute	10BASE-T/100BASE-TX
Operation mode	Full duplex
Compliance standard	IEEE 802.3

5.7.6 Technical Specifications

Table 5-35 describes technical specifications of the VAMPA.

Table 5-35 Technical specifications of the VAMPA

Parameter	Description
Board dimensions (W x D x H)	394.70 mm x 426.80 mm x 35.10 mm
Maximum power consumption	120 W
Board weight	2.6 kg

5.8 G48S - 48-Port 100/1000BASE-X Interface Card (SFP)

This section describes the 48-Port 100/1000BASE-X Interface Card (EA, SFP), 48-Port 100/1000BASE-X Interface Card (EC, SFP), 48-Port 100/1000BASE-X Interface Card (ED, SFP) and 48-Port 100/1000BASE-X Interface Card (FA, SFP), including the appearance, functions and features, panel, interface attributes, and technical specifications.

5.8.1 Introduction

The 48-port optical interface line card (SFP) of the S7700 is called G48S and has the following models: (EA, SFP), (EC, SFP), (ED, SFP), and (FA, SFP).

Table 5-36 lists the board full names and MAC address table capacities.

Table 5-36 G48S models

Full Name	Short Name	MAC Address Table Capacity
48-port 100/1000BASE-X interface line card (EA, SFP)	G48SA	32K
48-port 100/1000BASE-X interface line card (EC, SFP)	G48SC	128K
48-port 100/1000BASE-X interface line card (ED, SFP)	G48SD	512K
48-port 100/1000BASE-X interface line card (FA, SFP)	G48SFA	32K

Both the G48SA and G48SFA support 32K MAC address entries. The power consumption of a G48SFA is smaller than that of a G48SA.

5.8.2 Function and Application

Function Description

The G48S provides 48 GE optical interfaces to implement data access and wire-speed switching.

Application

The G48S can be installed in any LPU slot on the S7712, S7706, or S7703.

5.8.3 Panel

Figure 5-18 shows the appearance of the G48S panel.

Figure 5-18 Appearance of the G48S panel

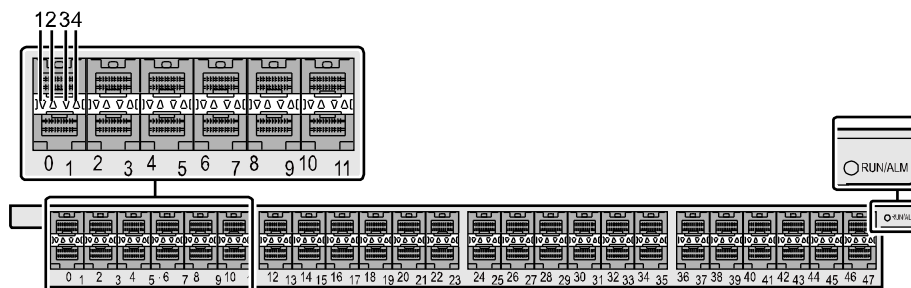

1. ACT indicators of the lower optical interfaces
2. ACT indicators of the upper optical interfaces
3. Link indicators of the lower optical interfaces
4. Link indicators of the upper optical interfaces

Buttons and Indicators on the Panel

Table 5-37 describes the buttons and indicators on the G48S panel.

Table 5-37 Description of buttons and indicators on the G48S panel

Indicator/Button	Color	Description
RUN/ALM	Green	If the indicator is on, it indicates that the LPU is powered on, but the software is not running. If the indicator blinks every 2s (0.5 Hz), it indicates that the system is running normally. If the indicator blinks every 0.25s (4 Hz), it indicates that the system is starting.
	Red	If the indicator is in red, it indicates that the LPU is faulty.
	Orange	If the indicator is in orange, it indicates that the LPU is installed, and the board is powered off.
ACT	Amber	If the indicator blinks, the data is being transmitted or received.
LINK	Green-yellow	If the indicator is on, it indicates that the link is connected.

5.8.4 Interfaces

Interfaces

Table 5-38 describes the types and functions of the interfaces on the G48S.

Table 5-38 Types and functions of the interfaces on the G48S

Name	Quantity	Description
100M/1000M BASE-X optical interface	48	The G48S provides 48 Ethernet optical interfaces (100M/1000M auto sensing) to transmit and receive Ethernet services.

5.8.5 Interface Attributes

Table 5-39 Interface attributes of the GE optical LPU (100M/1000M Base-SFP)

Attribute	Description
Connector type	LC/PC
Optical interface attribute	Depending on the SFP optical module.
Compliance standard	IEEE 802.3z
Frame format	Ethernet_II, Ethernet_SAP, or Ethernet_SNAP
Network protocol	IP

Table 5-40 Attributes of the SFP optical module (GE)

Attribute	Description							
	500 m	10 km	10 km (single-mode bidirectional fiber)		40 km	40 km	80 km	100 km
Center wavelength	850 nm	1310 nm	Tx: 1310 nm Rx: 1490 nm	Tx: 1490 nm Rx: 1310 nm	1310 nm	1550 nm	1550 nm	1550 nm
Transmitting power	-9.5 dBm to -2.5 dBm	-9.0 dBm to -3.0 dBm	-9.0 dBm to -3.0 dBm	-9.0 dBm to -3.0 dBm	-5.0 dBm to 0 dBm	-5.0 dBm to 0 dBm	-2.0 dBm to 5.0 dBm	0 dBm to 5 dBm
Receiver sensitivity	-17.0 dBm	-20.0 dBm	-19.5 dBm	-19.5 dBm	-23 dBm	-22 dBm	-23.0 dBm	-30.0 dBm
Overload optical power	0 dBm	-3.0 dBm	-3.0 dBm	-3.0 dBm	-3.0 dBm	-3.0 dBm	-3.0 dBm	-9.0 dBm

Attribute	Description							
Extinction ratio	9 dB	9 dB	6 dB	6 dB	9 dB	8.5 dB	9 dB	8 dB
Fiber type	Multi-mode Modal bandwidth: 400Mkm Fiber diameter: 50 um	Single-mode						

Table 5-41 Attributes of an ESFP-CWDM optical module (100 Mbit/s or 1000 Mbit/s)

Attribute	Description							
Transmission distance	80 km							
Center wavelength	1471 nm	1491 nm	1511 nm	1531 nm	1551 nm	1571 nm	1591 nm	1611 nm
Transmit optical power	0 dBm to 5.0 dBm							
Receiver sensitivity	-28.0 dBm							
Overload optical power	-9.0 dBm							
Extinction ratio	8.5 dB							

Table 5-42 Attributes of an ESFP-DWDM optical module (100 Mbit/s or 1000 Mbit/s)

Attribute	Description								
Transmission distance	120 km								
Center wavelength	1529.55 nm	1533.47 nm	1537.40 nm	1541.35 nm	1545.32 nm	1549.32 nm	1553.33 nm	1557.36 nm	
	1530.33 nm	1534.25 nm	1538.19 nm	1542.14 nm	1546.12 nm	1550.12 nm	1554.13 nm	1558.17 nm	
	1531.12 nm	1535.04 nm	1538.98 nm	1542.94 nm	1546.92 nm	1550.92 nm	1554.94 nm	1558.98 nm	
	1531.90 nm	1535.82 nm	1539.77 nm	1543.73 nm	1547.72 nm	1551.72 nm	1555.75 nm	1559.79 nm	
	1532.68 nm	1536.61 nm	1540.56 nm	1544.53 nm	1548.51 nm	1552.52 nm	1556.56 nm	1560.61 nm	
Transmit optical power	0 dBm to 4.0 dBm								
Receiver sensitivity	-28.0 dBm								
Overload optical power	-8.0 dBm								
Extinction ratio	8.2 dB								
Operating temperature	0°C to 45°C								

Table 5-43 Attributes of copper modules

Attribute	Description
Connector	RJ45
Standards compliance	IEEE802.3ab
Frame format	Ethernet_II, Ethernet_SAP, or Ethernet_SNAP

Attribute	Description
Network protocol	IP

5.8.6 Technical Specifications

[Table 5-44](#) describes the technical specifications of the G48S.

Table 5-44 Technical specifications of the G48S

Item	Specification
Board dimensions (depth x width x height)	426.8 mm x 394.7 mm x 35.1 mm
Maximum power consumption	G48SA: 75 W G48SC: 92 W G48SD: 110 W G48SFA: 65 W
Weight	G48SA: 2.54 kg G48SC: 2.66 kg G48SD: 2.66 kg G48SFA: 2.60 kg
Long-term temperature	0°C to 45°C
Short-term temperature	-5°C to 55°C

5.9 G48T - 48-Port 10/100/1000BASE-T Interface Card (RJ45)

This section describes the 48-Port 100/1000BASE-T Interface Card (EA, RJ45), 48-Port 10/100/1000BASE-T Interface Card (EC, RJ45) and 48-Port 1000BASE-T Interface Card (FA, RJ45), including the appearance, functions and features, panel, and technical specifications.

5.9.1 Introduction

The 48-port GE electrical interface card (RJ45) of the S7700 is called G48T for short and has the following models: 48-port 10M/100M/1000M electrical interface card (EA, RJ45), 48-port 10M/100M/1000M electrical interface card (EC, RJ45), and 48-port 10M/100M/1000M electrical interface card (FA, RJ45).

[Table 5-45](#) provides the full name of the interface cards and capacities of their MAC address tables.

Table 5-45 Lists of G48T cards

Full Name	Short Name	Capacity of MAC Address Table
48-Port 10/100/1000BASE-T Interface Card (EA, RJ45)	G48TA	32K
48-Port 10/100/1000BASE-T Interface Card (EC, RJ45)	G48TC	128K
48-Port 10/100/1000BASE-T Interface Card (FA, RJ45)	G48TFA	32K

Both the G48TA and G48TFA support 32K MAC addresses. The power consumption of the G48TFA is smaller than that of the G48TA.

5.9.2 Function and Application

Function Description

The G48T provides 48 GE electrical interfaces to implement data access and wire-speed switching.

Application

The G48T can be installed in any LPU slot on the S7712, S7706 or S7703.

5.9.3 Panel

Figure 5-19 shows the appearance of the G48T panel.

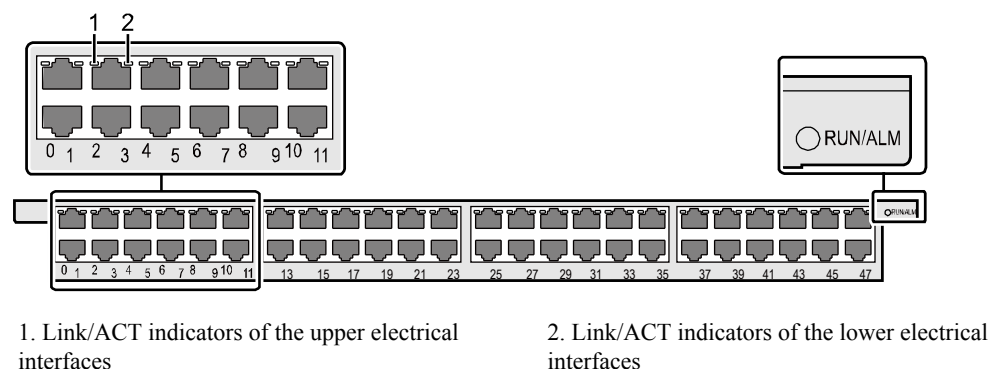
Figure 5-19 Appearance of the G48T panel

Buttons and Indicators on the Panel

Table 5-46 describes the buttons and indicators on the G48T panel.

Table 5-46 Description of buttons and indicators on the G48T panel

Indicator/Button	Color	Description
RUN/ALM	Green	If the indicator is on, it indicates that the LPU is powered on, but the software is not running. If the indicator blinks every 2s (0.5 Hz), it indicates that the system is running normally. If the indicator blinks every 0.25s (4 Hz), it indicates that the system is starting.
	Red	If the indicator is in red, it indicates that the LPU is faulty.
	Yellow	If the indicator is in yellow, it indicates that the LPU is installed, and the board is powered off.
Link/ACT	Green	If the indicator is on, it indicates that the link is connected. If the indicator blinks, the data is being transmitted or received.

5.9.4 Interfaces

Table 5-47 describes the types and functions of the interfaces on the G48T.

Table 5-47 Types and functions of the interfaces on the G48T

Name	Quantity	Description
10M/100M/1000M BASE-T electrical interface	48	The G48T provides 48 Ethernet electrical interfaces (10M/100M/1000M auto sensing) to transmit and receive Ethernet services.

5.9.5 Interface Attributes

Table 5-48 Attributes of the 10M/100M/1000M Base-T Ethernet interface

Attribute	Description
Connector type	RJ45
Compliance standard	IEEE 802.3ab

Attribute	Description
Frame format	Ethernet_II, Ethernet_SAP, Ethernet_SNAP
Network protocol	IP

5.9.6 Technical Specifications

Table 5-49 describes the technical specifications of a G48T.

Table 5-49 Technical specifications of a G48T

Item	Specification
Dimensions (H x W x D)	35.1 mm x 394.7 mm x 426.8 mm
Maximum power consumption	G48TA: 62 W G48TC: 68 W G48TFA: 48 W
Weight	G48TA: 2.50 kg G48TC: 2.66 kg G48TFA: 2.50 kg
Long-term temperature	0°C to 45°C
Short-term temperature	-5°C to 55°C

5.10 G48VA - 48-Port 10/100/1000BASE-T PoE Interface Card (EA,RJ45,PoE)

This section describes the 48-Port 10/100/1000BASE-T PoE Interface Card, including the appearance, functions and features, applicable device, slot, panel, indicators, interfaces, and technical specifications.

5.10.1 Introduction

The 48-port 10/100M/1000M Ethernet PoE electrical interface card (EA, RJ45, PoE) is called G48VA for short.

The G48VA is a GE electrical interface card. It supports the power over Ethernet (PoE) function.

The G48VA provides 48 GE interfaces and such functions as the data switching unit and PoE management unit. The G48VA has the following functions:

- Implementing data access and line-speed switching on GE electrical interfaces
- Providing data signals and DC power for the directly connected devices such as the IP phone, access point (AP) of the wireless local area network (WLAN), and Web camera

5.10.2 Function and Application

Function

The G48VA of the S7700 consists of the following functional units:

- Data switching unit: consists of the CPU, LAN switch, and physical layer (PHY).
- PoE management unit: consists of the CPU and the Dual Inline Memory Module (DIMM).

The functions of the G48VA are as follows:

- Implementing data access and line-speed switching on 48 GE electrical interfaces
- Providing the PoE function

Application

The G48VA can be installed in any LPU slot of the S7703, S7706 or S7712.

The G48VA can provide the PoE function only when the chassis supports the PoE function.

NOTE

The G48VA can start and register only when the following conditions are met:

- The DIMM module is installed in the DIMM slot on the board.
- The PoE chassis is used..
- A PoE power supply is installed and working normally.

5.10.3 Panel

Figure 5-20 shows the appearance of the G48VA panel.

Figure 5-20 Appearance of the G48VA panel

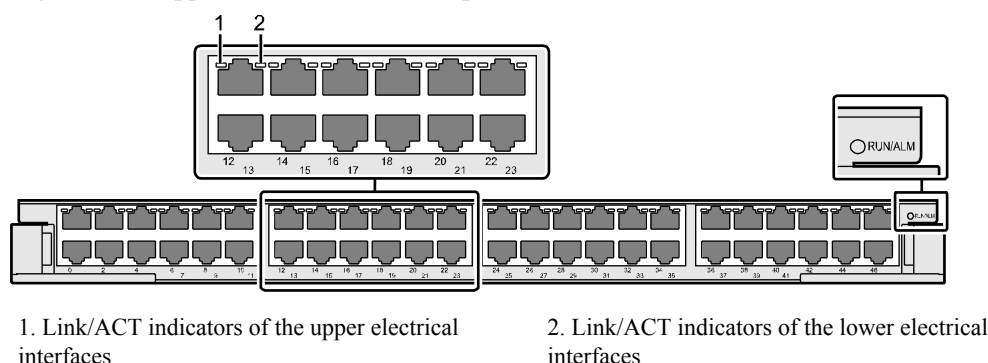

Buttons and Indicators on the Panel

Table 5-50 describes the buttons and indicators on the G48VA panel.

Table 5-50 Description of buttons and indicators on the G48VA panel

Indicator/Button	Color	Meaning
RUN/ALM	Green	If the indicator is on, it indicates that the board is powered on but the software is not running. If the indicator blinks once every 2s (0.5 Hz), it indicates that the system is in normal state. If the indicator blinks once every 0.25s (4 Hz), it indicates that the system is being started.
	Red	If the indicator is in red, it indicates that the board is faulty.
	Orange	If the indicator is in orange, it indicates that the board is Steady on (both the red and green LEDs are on): installed in the slot and is powered off..
Link/ACT	Green	If the indicator is on, it indicates that the link is connected. If the indicator blinks, it indicates that data is being transmitted.

5.10.4 Interfaces

Table 5-51 describes the types and functions of the interfaces on the G48VA.

Table 5-51 Types and functions of the interfaces on the G48VA

Name	Quantity	Description
10M/100M/1000M BASE-T electrical interface	48	The G48VA provides 48 Ethernet electrical interfaces (10M/100M/1000M auto sensing) to transmit and receive Ethernet services. The G48VA provides the PoE function and can provide DC power for the directly connected devices such as the IP phone, WLAN AP, and Web camera.

5.10.5 Interface Attributes

Table 5-52 Attributes of the 10M/100M/1000M Base-T Ethernet interface

Attribute	Description
Connector type	RJ45
Compliance standard	IEEE 802.3ab
Frame format	Ethernet_II, Ethernet_SAP, Ethernet_SNAP
Network protocol	IP

5.10.6 Technical Specifications

Table 5-53 describes the technical specifications of the G48VA.

Table 5-53 Technical specifications of the G48VA

Item	Specification
Board dimensions (depth x width x height)	426.8 mm x 394.7 mm x 35.1 mm
Maximum power consumption	64 W (excluding PoE power consumption)
Weight	2.60 kg
Maximum output power	Interface: 30 W Board: 1440 W
Long-term temperature	0°C to 45°C
Short-term temperature	-5°C to 55°C

5.11 G48CEAT - 36-Port 10/100/1000BASE-T and 12-Port 100/1000BASE-X Interface Card(EA, RJ45/SFP)

This section describes the 36-Port 10/100/1000BASE-T and 12-Port 100/1000BASE-X Interface Card(EA,RJ45/SFP), including the appearance, functions and features, applicable devices, slots, panel, indicators, interfaces, and technical specifications.

5.11.1 Introduction

The 36-port 10M/100M/1000M Ethernet electrical interface + 12-port 100M/1000M Ethernet optical interface line card (EA, RJ45/SFP) supported by the S7700 is called G48CEAT and supports 32K MAC address entries.

5.11.2 Function and Application

Function

A G48CEAT board provides 36-port 10M/100M/1000M Ethernet electrical interfaces and 12-port 100M/1000M Ethernet optical interfaces to implement data access and wire-speed switching.

Application

A G48CEAT can be installed in any LPU slot of the S7712, S7706, or S7703.

5.11.3 Panel

Figure 5-21 shows the appearance of the G48CEAT panel.

Figure 5-21 Appearance of the G48CEAT panel

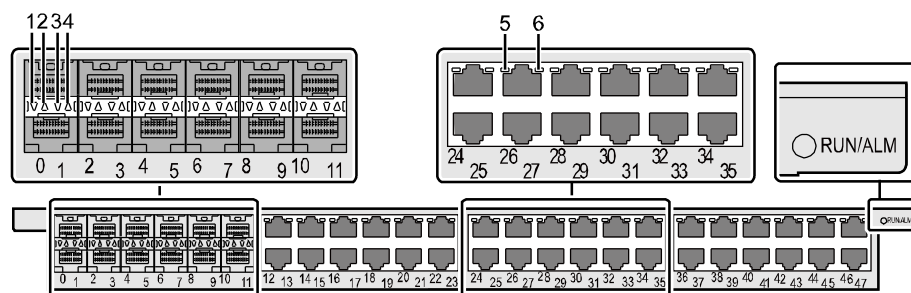

- | | | | |
|---|---|---|---|
| 1. ACT indicator of the lower optical interfaces | 2. ACT indicator of the upper optical interfaces | 3. Link indicator of the lower optical interfaces | 4. Link indicator of the upper optical interfaces |
| 5. Link/ACT indicators of the upper electrical interfaces | 6. Link/ACT indicators of the lower electrical interfaces | | |

Buttons and Indicators on the Panel

Table 5-54 describes the buttons and indicators on the G48CEAT panel.

Table 5-54 Description of buttons and indicators on the G48CEAT panel

Indicator/Button	Color	Description
RUN/ALM	Green	If the indicator is on, it indicates that the board is powered on but the software is not running. If the indicator blinks once every 2s (0.5 Hz), it indicates that the system is in normal state. If the indicator blinks once every 0.25s (4 Hz), it indicates that the system is being powered on or being restarted.
	Red	If the indicator is on, it indicates that the board is faulty.
	Orange	If the indicator is on, it indicates that the board is installed in a slot and the CBUS is powered on.
ACT indicator of optical interfaces	Amber	If the indicator blinks, it indicates that data is being transmitted.
Link indicator of optical interfaces	Green-yellow	If the indicator is on, it indicates that the link is connected.
ACT/Link indicators of electrical interfaces	Green	If the indicator blinks, it indicates that data is being transmitted. If the indicator is on, it indicates that the link is connected.

5.11.4 Interfaces

Table 5-55 describes the types and functions of the interfaces on the G48CEAT.

Table 5-55 Types and functions of the interfaces on the G48CEAT

Name	Quantity	Description
100M/1000M BASE-X optical interface	12	The G48CEAT provides 12 100M/1000M optical interfaces to transmit and receive GE services.
10M/100M/1000M BASE-T electrical interface	36	The G48CEAT provides 36 10M/100M/1000M electrical interfaces to transmit and receive GE services.

5.11.5 Interface Attributes

The G48CEAT provides only data interfaces. An optical interface can be connected to an optical module.

Table 5-56 Interface attributes of the GE optical LPU (100M/1000M Base-SFP)

Attribute	Description
Connector type	LC/PC
Optical interface attribute	Depending on the SFP optical module.
Compliance standard	IEEE 802.3z
Frame format	Ethernet_II, Ethernet_SAP, or Ethernet_SNAP
Network protocol	IP

Table 5-57 Attributes of the SFP optical module (GE)

Attribute	Description							
	500 m	10 km	10 km (single-mode bidirectional fiber)		40 km	40 km	80 km	100 km
Center wavelength	850 nm	1310 nm	Tx: 1310 nm Rx: 1490 nm	Tx: 1490 nm Rx: 1310 nm	1310 nm	1550 nm	1550 nm	1550 nm
Transmitting power	-9.5 dBm to -2.5 dBm	-9.0 dBm to -3.0 dBm	-9.0 dBm to -3.0 dBm	-9.0 dBm to -3.0 dBm	-5.0 dBm to 0 dBm	-5.0 dBm to 0 dBm	-2.0 dBm to 5.0 dBm	0 dBm to 5 dBm
Receiver sensitivity	-17.0 dBm	-20.0 dBm	-19.5 dBm	-19.5 dBm	-23 dBm	-22 dBm	-23.0 dBm	-30.0 dBm
Overload optical power	0 dBm	-3.0 dBm	-3.0 dBm	-3.0 dBm	-3.0 dBm	-3.0 dBm	-3.0 dBm	-9.0 dBm

Attribute	Description							
Extinction ratio	9 dB	9 dB	6 dB	6 dB	9 dB	8.5 dB	9 dB	8 dB
Fiber type	Multi-mode Modal bandwidth: 400Mkm Fiber diameter: 50 um	Single-mode						

Table 5-58 Attributes of an ESFP-CWDM optical module (100 Mbit/s or 1000 Mbit/s)

Attribute	Description							
Transmission distance	80 km							
Center wavelength	1471 nm	1491 nm	1511 nm	1531 nm	1551 nm	1571 nm	1591 nm	1611 nm
Transmit optical power	0 dBm to 5.0 dBm							
Receiver sensitivity	-28.0 dBm							
Overload optical power	-9.0 dBm							
Extinction ratio	8.5 dB							

Table 5-59 Attributes of copper modules

Attribute	Description
Connector	RJ45
Standards compliance	IEEE802.3ab
Frame format	Ethernet_II, Ethernet_SAP, or Ethernet_SNAP
Network protocol	IP

Table 5-60 Attributes of the 10M/100M/1000M Base-T Ethernet interface

Attribute	Description
Connector type	RJ45
Compliance standard	IEEE 802.3ab
Frame format	Ethernet_II, Ethernet_SAP, Ethernet_SNAP
Network protocol	IP

5.11.6 Technical Specifications

Table 5-61 describes the technical specifications of the G48CEAT.

Table 5-61 Technical specifications of the G48CEAT

Item	Specification
Board dimensions (depth x width x height)	426.8 mm x 394.7 mm x 35.1 mm
Power consumption	62 W
Weight	2.50 kg
Long-term temperature	0°C to 45°C
Short-term temperature	-5°C to 55°C

5.12 F48T - 48-Port 10/100BASE-T Interface Card (RJ45)

This section describes the 48-Port 10/100BASE-T Interface Card (EA, RJ45), 48-Port 10/100BASE-T Interface Card (EC, RJ45) and 48-Port 10/100BASE-T Interface Card (FA, RJ45), including the appearance, functions and features, panel, and technical specifications.

5.12.1 Introduction

The 48-port FE electrical interface line card (RJ45) of the S7700 is called F48T and has the following models: (EA, RJ45), (EC, RJ45), and (FA, RJ45).

Table 5-62 lists the board full names and MAC address table capacities.

Table 5-62 F48T models

Full Name	Short Name	MAC Address Table Capacity
48-port 10/100BASE-T interface card (EA, RJ45)	F48TA	32K
48-port 10/100BASE-T interface card (EC, RJ45)	F48TC	128K
48-port 10/100BASE-T interface card (FA, RJ45)	F48TFA	32K

Both the F48TA and F48TFA support 32K MAC address entries. The power consumption of an F48TFA board is smaller than that of an F48TA board.

5.12.2 Function and Application

Function

An F48T board provides 48 FE electrical interfaces to implement data access and wire-speed switching.

Application

An F48T can be installed in any LPU slot on the S7712, S7706, or S7703.

5.12.3 Panel

Figure 5-22 shows the appearance of an F48T panel.

Figure 5-22 Appearance of an F48T panel

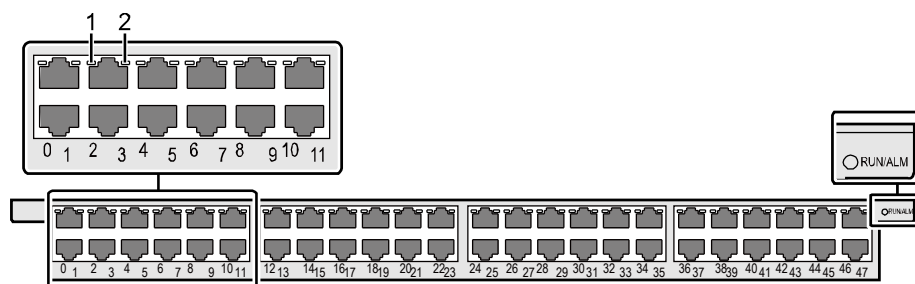

1. Link/ACT indicator of the upper electrical interfaces 2. Link/ACT indicator of the lower electrical interfaces

Buttons and Indicators on a Panel

Table 5-63 describes the buttons and indicators on an F48T panel.

Table 5-63 Buttons and indicators on an F48T panel

Indicator/Button	Color	Description
RUN/ALM	Green	If the indicator is on, the board is powered on, but the software is not running. If the indicator blinks once every 2s (0.5 Hz), the system is running properly. If the indicator blinks once every 0.25s (4 Hz), the system is starting.
	Red	If the indicator is steady red, the board is faulty.
	Orange	If the indicator is steady orange, the board is installed and powered off.
Link/ACT	Green	If the indicator is on, the link is connected. If the indicator blinks, data is being transmitted or received.

5.12.4 Interfaces

Table 5-64 describes the types and functions of the interfaces on an F48T.

Table 5-64 Types and functions of the interfaces on an F48T board

Name	Quantity	Description
10M/100M BASE-T electrical interface	48	An F48T board provides 48 Ethernet electrical interfaces (10Mbit/s or 100 Mbit/s) to transmit and receive Ethernet services.

5.12.5 Interface Attributes

Table 5-65 describes the attributes of the 100M Base-T Ethernet interface.

Table 5-65 Attributes of the 10M/100M Base-T Ethernet interface

Attribute	Description
Connector type	RJ45
Compliance standard	IEEE 802.3
Frame format	Ethernet_II, Ethernet_SAP, or Ethernet_SNAP
Network protocol	IP

5.12.6 Technical Specifications

Table 5-66 describes the technical specifications of a 48-port FE electrical interface line card.

Table 5-66 Technical specifications of a 48-port FE electrical interface line card

Item	Specification
Dimensions (depth x width x height)	426.8 mm x 394.7 mm x 35.1 mm
Maximum power consumption	F48TA: 59 W F48TC: 70 W F48TFA: 40 W
Weight	F48TA: 2.50 kg F48TC: 2.66 kg F48TFA: 2.30 kg
Long-term temperature	0°C to 45°C
Short-term temperature	-5°C to 55°C

5.13 X40SFC-40-Port 10GE Optical Interface Card (FC, SFP+)

This section describes the X40SFC-40-port 10GE optical interface card (FC, SFP+), including the functions and features, applicable device models and slots, panel, indicators, interface attributes, and technical specifications.

5.13.1 Introduction

The 40-port 10GE optical interface line card (FC, SFP+) of the S7700 is called X40SFC and provides 40 10GE interfaces. It supports 128K MAC address entries.

5.13.2 Function and Application

Function

An X40SFC board provides 40 10GE optical interfaces to implement data access and wire-speed switching.

Application

An X40SFC board can be installed in any LPU slot of the .

5.13.3 Panel

[Figure 5-23](#) shows the appearance of the X40SFC panel.

Figure 5-23 Appearance of the X40SFC panel

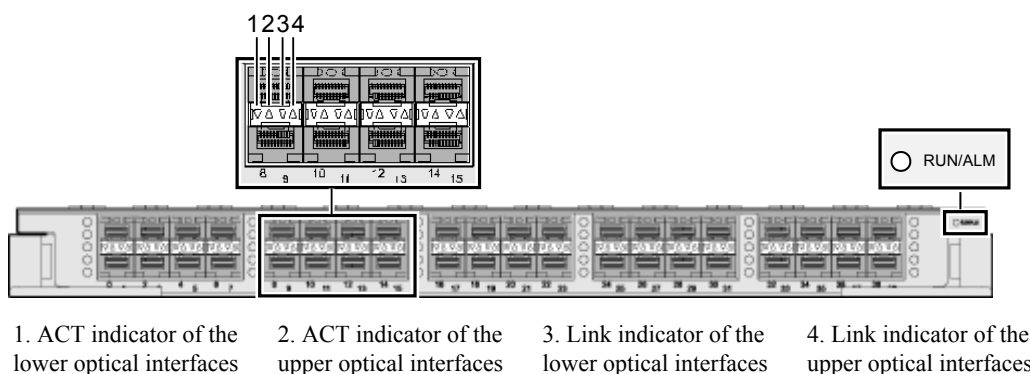

Buttons and Indicators on the Panel

[Table 5-67](#) describes the indicators on the X40SFC panel.

Table 5-67 Description of indicators on the X40SFC panel

Indicator	Color	Description
RUN/ALM	Green	<ul style="list-style-type: none"> ● If the indicator is on, it indicates that the board is powered on, but the software is not running. ● If the indicator blinks once every 2s (0.5 Hz), it indicates that the system is in normal state. ● If the indicator blinks once every 0.25s (4 Hz), it indicates the system is being powered on or being restarted.
	Red	If the indicator is on, it indicates that the board is faulty.
	Orange	If the indicator is in orange, it indicates that the board is installed in a slot and the CBUS is powered on.
ACT	Amber	If the indicator blinks, data is being transmitted or received.
Link	Green-yellow	If the indicator is on, it indicates that the link is connected.

5.13.4 Interfaces

Table 5-68 describes the types and functions of the interfaces on the X40SFC.

Table 5-68 Types and functions of the interfaces on the X40SFC

Name	Quantity	Description
10G BASE-SFP+/ 1000M BASE-X optical interface	40	The X40SFC provides forty 10 Gbit/s optical interfaces or forty 1000 Mbit/s optical interfaces to transmit and receive Ethernet services at 10 Gbit/s or 1000 Mbit/s.

5.13.5 Interface Attributes

An X40SFC board provides only data interfaces. An optical interface can be connected to an optical module. **Table 5-69** and **Table 5-71** describe the attributes of the optical interfaces and optical modules.

Table 5-69 Attributes of a 10G Base-SFP+ Ethernet optical interface

Attribute	Description
Connector	LC/PC
Optical interface attribute	Determined by the optical module. For details about the attributes of the optical module, see Table 5-71 and Table 5-72 .
Standards compliance	IEEE 802.3ae
Frame format	Ethernet_II, Ethernet_SAP, Ethernet_SNAP
Network protocol	IP

When SFP+ cables are used as interface cables, the interface attributes are shown in [Table 5-70](#).

Table 5-70 Attributes of a 10G Base-SFP+ Ethernet optical interface

Attribute	Description
Connector	SFP+
Standards compliance	IEEE 802.3ae
Frame format	Ethernet_II, Ethernet_SAP, Ethernet_SNAP
Network protocol	IP

Table 5-71 Attributes of an SFP+ optical module (10 Gbit/s)

Attribute	Description		
Transmission distance	220 m	300 m	10 km
Center wavelength	1310 nm	850 nm	1310 nm
Transmit power	-6.5 dBm to -0.5 dBm	-7.3 dBm to -1.0 dBm	-8.2 dBm to 0.5 dBm
Receiver sensitivity	-6.5 dBm	-11.1 dBm	-12.6 dBm
Overload optical power	1.5 dBm	-1.0 dBm	0.5 dBm
Extinction ratio	3.5 dB	3.0 dB	3.5 dB
Fiber type	OM1/OM2, multi-mode	OM3, multi-mode	Single-mode

Table 5-72 Attributes of an SFP+ optical module (1000 Mbit/s)

Attribute	Description							
	Transmission distance	500 m	10 km	10 km (single-mode bidirectional fiber)		40 km	40 km	80 km
Center wavelength	850 nm	1310 nm	Tx1310 nm Rx1490 nm	Tx1490 nm Rx1310 nm	1310 nm	1550 nm	1550 nm	1550 nm
Transmit optical power	-9.5 dBm to -2.5 dBm	-9.0 dBm to -3.0 dBm	-9.0 dBm to -3.0 dBm	-9.0 dBm to -3.0 dBm	-5.0 dBm to 0 dBm	-5.0 dBm to 0 dBm	-2.0 dBm to 5.0 dBm	0 dBm to 5.0 dBm
Receiver sensitivity	-17.0 dBm	-20.0 dBm	-19.5 dBm	-19.5 dBm	-23.0 dBm	-22.0 dBm	-23.0 dBm	-30.0 dBm
Overload optical power	0 dBm	-3.0 dBm	-3.0 dBm	-3.0 dBm	-3.0 dBm	-3.0 dBm	-3.0 dBm	-9.0 dBm
Extinction ratio	9.0 dB	9.0 dB	6.0 dB	6.0 dB	9.0 dB	8.5 dB	9.0 dB	8.0 dB
Optical fiber type	Multi-mode	Single-mode						

5.13.6 Technical Specifications

Table 5-73 describes the technical specifications of the X40SFC.

Table 5-73 Technical specifications of the X40SFC

Item	Specification
Dimensions (depth x width x height)	426.8 mm x 394.7 mm x 35.1 mm
Maximum power consumption	183 W
Weight	2.90 kg
Long-term temperature	0°C to 45°C
Short-term temperature	-5°C to 45°C

5.14 X16SFC-16-Port 10GE Optical Interface Card (FC, SFP+)

This section describes the X16SFC-16-port 10GE optical interface card (FC, SFP+), including the functions and features, applicable device models and slots, panel, indicators, interface attributes, and technical specifications.

5.14.1 Introduction

The 16-port 10GE optical interface card (FC, SFP+) of the S7700 is called X16SFC and provides 16 10GE interfaces. It supports 128K MAC address entries.

5.14.2 Function and Application

Function

An X16SFC board provides 16 10GE optical interfaces to implement data access and wire-speed switching.

Application

An X16SFC board can be installed in any LPU slot of the .

5.14.3 Panel

[Figure 5-24](#) shows the appearance of an X16SFC panel.

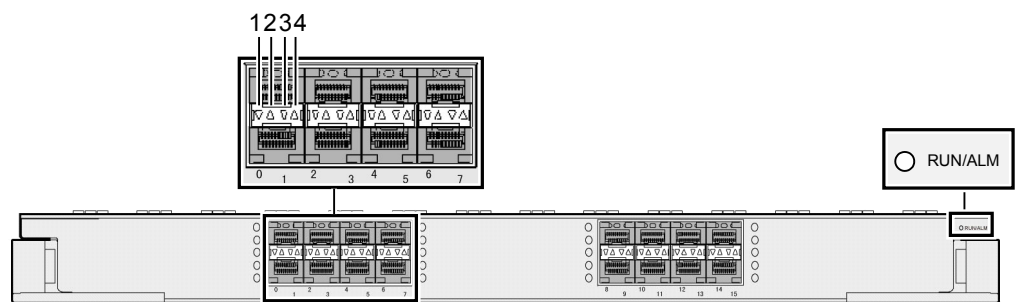
Figure 5-24 Appearance of an X16SFC panel

1. ACT indicator of the lower optical interfaces 2. ACT indicator of the upper optical interfaces 3. Link indicator of the lower optical interfaces 4. Link indicator of the upper optical interfaces

Buttons and Indicators on a Panel

Table 5-74 lists the buttons and indicators on an X16SFC panel.

Table 5-74 Buttons and indicators on an X16SFC panel

Indicator/Button	Color	Description
RUN/ALM	Green	<ul style="list-style-type: none"> If the indicator is on, the board is powered on, but the software is not running. If the indicator blinks once every 2s (0.5 Hz), the system is running properly. If the indicator blinks once every 0.25s (4 Hz), the system is powering on or is restarting.
	Red	If the indicator is on, a board is faulty.
	Orange	If the indicator is on, a board is installed and powered on through the CBUS.
ACT	Amber	If the indicator blinks, data is being transmitted or received.
Link	Green-yellow	If the indicator is on, the link is connected.

5.14.4 Interfaces

Table 5-75 describes the types and functions of interfaces on an X16SFC board.

Table 5-75 Types and functions of interfaces on an X16SFC board

Interface	Quantity	Description
10GE BASE-SFP+/ 1000M BASE-X optical interface	16	16 10GE or 1000 Mbit/s optical interfaces are provided to transmit and receive Ethernet services at 10 Gbit/s or 1000 Mbit/s.

5.14.5 Interface Attributes

An X16SFC board provides only data interfaces. An optical interface can be connected to an optical module. [Table 5-76](#), [Table 5-77](#) and [Table 5-78](#) describe the attributes of the optical interfaces and optical modules on an X16SFC board.

Table 5-76 Attributes of a 10GE optical interface

Attribute	Description
Connector	LC/PC
Optical interface attribute	Determined by the SFP+ optical module. For details about the optional optical module attributes, see Table 5-77 and Table 5-78 .
Standards compliance	IEEE 802.3ae
Frame format	Ethernet_II, Ethernet_SAP, Ethernet_SNAP
Network protocol	IP

Table 5-77 Attributes of an SFP+ optical module (10 Gbit/s)

Attribute	Description		
Transmission distance	220 m	300 m	10 km
Center wavelength	1310 nm	850 nm	1310 nm
Transmit optical power	-6.5 dBm to -0.5 dBm	-7.3 dBm to -1.0 dBm	-8.2 dBm to 0.5 dBm
Receiver sensitivity	-6.5 dBm	-11.1 dBm	-12.6 dBm
Overload optical power	1.5 dBm	-1.0 dBm	0.5 dBm
Extinction ratio	3.5 dB	3.0 dB	3.5 dB

Attribute	Description		
Optical fiber type	OM1/OM2 multi-mode	OM3 multi-mode	Single-mode

Table 5-78 Attributes of the SFP optical module (1000M bit/s)

Attribute	Description							
Transmission distance	500 m	10 km	10 km (single-mode bidirectional fiber)		40 km	40 km	80 km	100 km
Center wavelength	850 nm	1310 nm	Tx: 1310 nm Rx: 1490 nm	Tx: 1490 nm Rx: 1310 nm	1310 nm	1550 nm	1550 nm	1550 nm
Transmitting power	-9.5 dBm to -2.5 dBm	-9.0 dBm to -3.0 dBm	-9.0 dBm to -3.0 dBm	-9.0 dBm to -3.0 dBm	-5.0 dBm to 0 dBm	-5.0 dBm to 0 dBm	-2.0 dBm to 5.0 dBm	0 dBm to 5 dBm
Receiver sensitivity	-17.0 dBm	-20.0 dBm	-19.5 dBm	-19.5 dBm	-23 dBm	-22 dBm	-23.0 dBm	-30.0 dBm
Overload optical power	0 dBm	-3.0 dBm	-3.0 dBm	-3.0 dBm	-3.0 dBm	-3.0 dBm	-3.0 dBm	-9.0 dBm
Extinction ratio	9 dB	9 dB	6 dB	6 dB	9 dB	8.5 dB	9 dB	8 dB

Attribute	Description	
Fiber type	Multi-mode	Single-mode
	Modal bandwidth: 400Mkm	
	Fiber diameter: 50 um	

5.14.6 Technical Specifications

Table 5-79 describes the technical specifications of an X16SFC board.

Table 5-79 Technical specifications of an X16SFC board

Parameter	Description
Dimensions (depth x width x height)	426.8 mm x 394.7 mm x 35.1 mm
Maximum power consumption	150 W
Weight	2.60 kg
Long-term operating temperature	0°C to 45°C
Short-term operating temperature	-5°C to 45°C

5.15 G24CA - 24-Port 100/1000BASE-X and 8-Port 10/100/1000BASE-T Interface Card (SFP/RJ45)

This section describes the 24-Port 100/1000BASE-X and 8-Port 10/100/1000BASE-T Interface Card (SA, SFP/RJ45), including the appearance, functions and features, panel, interface attributes, and technical specifications.

5.15.1 Introduction

The 24-port 100M/1000M Ethernet optical interface + 8-port 10M/100M/1000M Combo electrical interface line card (SA, SFP/RJ45) is called G24CA and provides 8 electrical interfaces and 24 optical interfaces. The first eight optical interfaces are used with the eight electrical interfaces as combo interfaces.

5.15.2 Function and Application

Function

The G24CA provides 16 GE optical interfaces and 8 combo interfaces. The combo interfaces can function as either optical interfaces or electrical interfaces.

By default, a combo interface works in the auto mode. In the auto mode, if the electrical interface is connected to a network cable first, the combo interface works as an electrical interface to transmit data; if the optical interface is connected to a fiber first, the combo interface works as an optical interface to transmit data.

 **NOTE**

On the G24CA, at most 24 interfaces, including the GE interfaces and combo interfaces, can work at the same time.

Application

A G24CA can be installed in any LPU slot of the S7712, S7706, or S7703.

5.15.3 Panel

Figure 5-25 shows the appearance of the G24CA panel.

Figure 5-25 Appearance of the G24CA panel

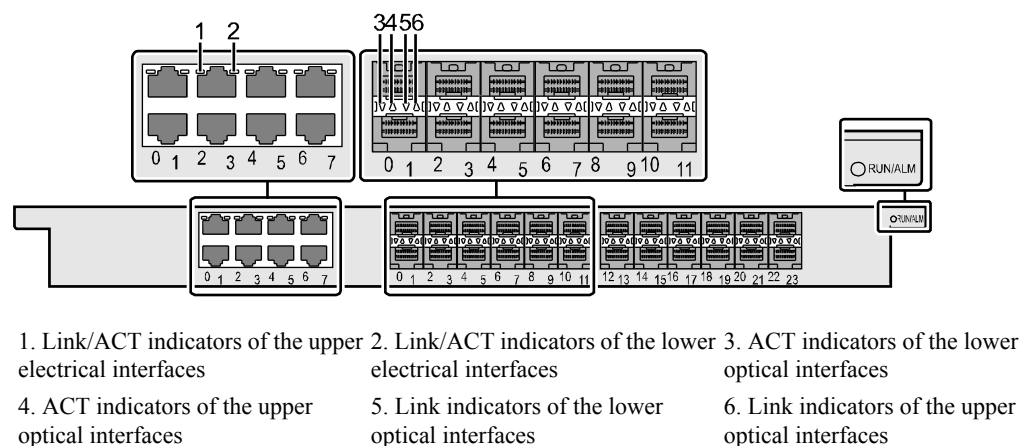

Buttons and Indicators on the Panel

Table 5-80 describes the buttons and indicators on the G24CA panel.

Table 5-80 Description of buttons and indicators on the G24CA panel

Indicator/Button	Color	Description
RUN/ALM	Green	If the indicator is on, it indicates that the LPU is powered on, but the software is not running. If the indicator blinks 2s (0.5 Hz), it indicates that the system is running normally. If the indicator blinks every 0.25s (4 Hz), it indicates that the system is starting.
	Red	If the indicator is in red, it indicates that the LPU is faulty.
	Orange	If the indicator is in orange, it indicates that the LPU is installed, and the board is powered off.
ACT	Amber	If the indicator blinks, the data is being transmitted or received.
LINK	Green-yellow	If the indicator is on, it indicates that the link is connected.
Link/ACT	Green	If the indicator is on, it indicates that the link is connected. If the indicator blinks, the data is being transmitted or received.

5.15.4 Interfaces

Table 5-81 describes the types and functions of the interfaces on the G24CA.

Table 5-81 Types and functions of the interfaces on the G24CA

Name	Quantity	Description
100/1000M BASE-T electrical interface	8	The G24CA provides 8 Ethernet electrical interfaces (100M/1000M auto sensing) to transmit and receive 1000 Mbit/s Ethernet services.
100/1000M BASE-X optical interface	24	The G24CA provides 24 Ethernet optical interfaces (100M/1000M auto sensing) to transmit and receive 1000 Mbit/s Ethernet services.

NOTE

A Combo interface works as either an optical interface or an electrical interface. You can run the **combo-port { auto | copper | fiber }** command to set the mode of the Combo interface.

5.15.5 Interface Attributes

The G24CA provides only data interfaces. Each optical interface uses an optical module.

Table 5-82 Interface attributes of the GE optical LPU (100M/1000M Base-SFP)

Attribute	Description
Connector type	LC/PC
Optical interface attribute	Depending on the SFP optical module.
Compliance standard	IEEE 802.3z
Frame format	Ethernet_II, Ethernet_SAP, or Ethernet_SNAP
Network protocol	IP

Table 5-83 Attributes of the SFP optical module (GE)

Attribute	Description							
	500 m	10 km	10 km (single-mode bidirectional fiber)		40 km	40 km	80 km	100 km
Center wavelength	850 nm	1310 nm	Tx: 1310 nm Rx: 1490 nm	Tx: 1490 nm Rx: 1310 nm	1310 nm	1550 nm	1550 nm	1550 nm
Transmitting power	-9.5 dBm to -2.5 dBm	-9.0 dBm to -3.0 dBm	-9.0 dBm to -3.0 dBm	-9.0 dBm to -3.0 dBm	-5.0 dBm to 0 dBm	-5.0 dBm to 0 dBm	-2.0 dBm to 5.0 dBm	0 dBm to 5 dBm
Receiver sensitivity	-17.0 dBm	-20.0 dBm	-19.5 dBm	-19.5 dBm	-23 dBm	-22 dBm	-23.0 dBm	-30.0 dBm

Attribute	Description							
Overload optical power	0 dBm	-3.0 dBm	-3.0 dBm	-3.0 dBm	-3.0 dBm	-3.0 dBm	-3.0 dBm	-9.0 dBm
Extinction ratio	9 dB	9 dB	6 dB	6 dB	9 dB	8.5 dB	9 dB	8 dB
Fiber type	Multi-mode Modal bandwidth: 400Mkm Fiber diameter: 50 um	Single-mode						

Table 5-84 Attributes of an ESFP-CWDM optical module (100 Mbit/s or 1000 Mbit/s)

Attribute	Description							
Transmission distance	80 km							
Center wavelength	1471 nm	1491 nm	1511 nm	1531 nm	1551 nm	1571 nm	1591 nm	1611 nm
Transmit optical power	0 dBm to 5.0 dBm							
Receiver sensitivity	-28.0 dBm							
Overload optical power	-9.0 dBm							
Extinction ratio	8.5 dB							

Table 5-85 Attributes of an ESFP-DWDM optical module (100 Mbit/s or 1000 Mbit/s)

Attribute	Description								
Transmission distance	120 km								
Center wavelength	1529.55 nm	1533.47 nm	1537.40 nm	1541.35 nm	1545.32 nm	1549.32 nm	1553.33 nm	1557.36 nm	
	1530.33 nm	1534.25 nm	1538.19 nm	1542.14 nm	1546.12 nm	1550.12 nm	1554.13 nm	1558.17 nm	
	1531.12 nm	1535.04 nm	1538.98 nm	1542.94 nm	1546.92 nm	1550.92 nm	1554.94 nm	1558.98 nm	
	1531.90 nm	1535.82 nm	1539.77 nm	1543.73 nm	1547.72 nm	1551.72 nm	1555.75 nm	1559.79 nm	
	1532.68 nm	1536.61 nm	1540.56 nm	1544.53 nm	1548.51 nm	1552.52 nm	1556.56 nm	1560.61 nm	
Transmit optical power	0 dBm to 4.0 dBm								
Receiver sensitivity	-28.0 dBm								
Overload optical power	-8.0 dBm								
Extinction ratio	8.2 dB								
Operating temperature	0°C to 45°C								

Table 5-86 Attributes of copper modules

Attribute	Description
Connector	RJ45
Standards compliance	IEEE802.3ab
Frame format	Ethernet_II, Ethernet_SAP, or Ethernet_SNAP

Attribute	Description
Network protocol	IP

Table 5-87 Attributes of the 10M/100M/1000M Base-T Ethernet interface

Attribute	Description
Connector type	RJ45
Compliance standard	IEEE 802.3ab
Frame format	Ethernet_II, Ethernet_SAP, Ethernet_SNAP
Network protocol	IP

5.15.6 Technical Specifications

Table 5-88 describes the technical specifications of the G24CA.

Table 5-88 Technical specifications of the G24CA

Item	Specification
Board dimensions (depth x width x height)	426.8 mm x 394.7 mm x 35.1 mm
Maximum power consumption	67 W
Weight	2.26 kg
Long-term temperature	0°C to 45°C
Short-term temperature	-5°C to 55°C

5.16 S24XA-24-Port 100M/1000M Ethernet Optical Interface + 2-Port 10GE Optical Interface Line Card (EA, SFP/XFP)

This section describes the 24-port 100/1000BASE-X and 2-port 10GBASE-X interface line card (EA, SFP/XFP), including the appearance, functions and features, panel, interface attributes, and technical specifications.

5.16.1 Introduction

The 24-port 100M/1000M Ethernet optical interface + 2-port 10GE optical interface line card (SFP/XFP) of the S7700 is called S24X and has the following models: (EA, SFP/XFP).

Table 5-89 lists the board full names and MAC address table capacities.

Table 5-89 S24X models

Full Name	Short Name	MAC Address Table Capacity
S24XA-24-port 100/1000BASE-X and 2-port 10GBASE-X interface line card (EA, SFP/XFP)	S24XA	32K

5.16.2 Function and Application

Function

An S24XA board provides 24 GE optical interfaces and two 10GE optical interfaces to implement data access and wire-speed switching.

Application

An S24XA board can be installed in any LPU slot of the S7703, S7706, or S7712.

5.16.3 Panel

Figure 5-26 shows the appearance of an S24XA panel.

Figure 5-26 Appearance of an S24XA panel

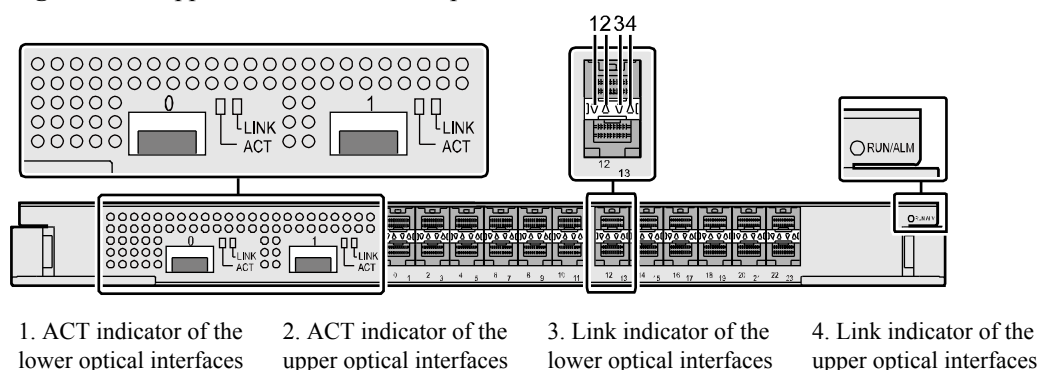

Buttons and Indicators on a Panel

Table 5-90 lists the buttons and indicators on an S24XA panel.

Table 5-90 Buttons and indicators on an S24XA panel

Indicator/Button	Color	Description
RUN/ALM	Green	If the indicator is on, the board is powered on, but the software is not running. If the indicator blinks once every 2s (0.5 Hz), the system is running properly. If the indicator blinks once every 0.25s (4 Hz), the system is powering on or is restarting.
	Red	If the indicator is steady red, the board is faulty.
	Orange	If the indicator is steady orange, the board is installed and powered off.
ACT	Amber	If the indicator blinks, data is being transmitted.
Link	Green-yellow	If the indicator is on, the link is connected.

5.16.4 Interfaces

Table 5-91 describes the types and functions of the interfaces on an S24XA board.

Table 5-91 Types and functions of the interfaces on an S24XA board

Name	Quantity	Description
100M/1000M BASE-X optical interface	24	An S24XA board provides 24 Ethernet optical interfaces (100M/1000M auto sensing) to transmit and receive Ethernet services at 1000 Mbit/s.
10G BASE-X optical interface	2	An S24XA board provides two 10GE optical interfaces to transmit and receive Ethernet services at 10 Gbit/s.

5.16.5 Interface Attributes

An S24XA board provides only data interfaces. Each interface has an optical module. The S24XA board provides GE optical interfaces and 10GE optical interfaces.

- The attributes of the GE interfaces and connected optical modules.

Table 5-92 Interface attributes of the GE optical LPU (100M/1000M Base-SFP)

Attribute	Description
Connector type	LC/PC
Optical interface attribute	Depending on the SFP optical module.
Compliance standard	IEEE 802.3z
Frame format	Ethernet_II, Ethernet_SAP, or Ethernet_SNAP
Network protocol	IP

Table 5-93 Attributes of the SFP optical module (GE)

Attribute	Description							
	500 m	10 km	10 km (single-mode bidirectional fiber)		40 km	40 km	80 km	100 km
Center wavelength	850 nm	1310 nm	Tx: 1310 nm Rx: 1490 nm	Tx: 1490 nm Rx: 1310 nm	1310 nm	1550 nm	1550 nm	1550 nm
Transmitting power	-9.5 dBm to -2.5 dBm	-9.0 dBm to -3.0 dBm	-9.0 dBm to -3.0 dBm	-9.0 dBm to -3.0 dBm	-5.0 dBm to 0 dBm	-5.0 dBm to 0 dBm	-2.0 dBm to 5.0 dBm	0 dBm to 5 dBm
Receiver sensitivity	-17.0 dBm	-20.0 dBm	-19.5 dBm	-19.5 dBm	-23 dBm	-22 dBm	-23.0 dBm	-30.0 dBm
Overload optical power	0 dBm	-3.0 dBm	-3.0 dBm	-3.0 dBm	-3.0 dBm	-3.0 dBm	-3.0 dBm	-9.0 dBm

Attribute	Description							
Extinction ratio	9 dB	9 dB	6 dB	6 dB	9 dB	8.5 dB	9 dB	8 dB
Fiber type	Multi-mode Modal bandwidth: 400Mkm Fiber diameter: 50 um	Single-mode						

Table 5-94 Attributes of an ESFP-CWDM optical module (100 Mbit/s or 1000 Mbit/s)

Attribute	Description							
Transmission distance	80 km							
Center wavelength	1471 nm	1491 nm	1511 nm	1531 nm	1551 nm	1571 nm	1591 nm	1611 nm
Transmit optical power	0 dBm to 5.0 dBm							
Receiver sensitivity	-28.0 dBm							
Overload optical power	-9.0 dBm							
Extinction ratio	8.5 dB							

Table 5-95 Attributes of an ESFP-DWDM optical module (100 Mbit/s or 1000 Mbit/s)

Attribute	Description								
Transmission distance	120 km								
Center wavelength	1529.55 nm	1533.47 nm	1537.40 nm	1541.35 nm	1545.32 nm	1549.32 nm	1553.33 nm	1557.36 nm	
	1530.33 nm	1534.25 nm	1538.19 nm	1542.14 nm	1546.12 nm	1550.12 nm	1554.13 nm	1558.17 nm	
	1531.12 nm	1535.04 nm	1538.98 nm	1542.94 nm	1546.92 nm	1550.92 nm	1554.94 nm	1558.98 nm	
	1531.90 nm	1535.82 nm	1539.77 nm	1543.73 nm	1547.72 nm	1551.72 nm	1555.75 nm	1559.79 nm	
	1532.68 nm	1536.61 nm	1540.56 nm	1544.53 nm	1548.51 nm	1552.52 nm	1556.56 nm	1560.61 nm	
Transmit optical power	0 dBm to 4.0 dBm								
Receiver sensitivity	-28.0 dBm								
Overload optical power	-8.0 dBm								
Extinction ratio	8.2 dB								
Operating temperature	0°C to 45°C								

Table 5-96 Attributes of an XFP-CWDM optical module (10 Gbit/s)

Attribute	Description
Transmission distance	70 km

Attribute	Description							
Center wavelength	1471 nm	1491 nm	1511 nm	1531 nm	1551 nm	1571 nm	1591 nm	1611 nm
Transmit optical power	0 dBm to 3.0 dBm							
Receiver sensitivity	-21.0 dBm							
Overload optical power	-9.0 dBm							
Extinction ratio	8.2 dB							

Table 5-97 Attributes of an XFP-DWDM optical module (10 Gbit/s)

Attribute	Description							
Transmission distance	80 km							
Center wavelength	1529.55 nm	1530.33 nm	1531.12 nm	1531.90 nm	1532.68 nm	1533.47 nm	1534.25 nm	1535.04 nm
	1548.51 nm	1549.32 nm	1550.12 nm	1550.92 nm	1551.72 nm	1552.52 nm	1553.33 nm	1554.13 nm
Transmit optical power	-1.0 dBm to 3.0 dBm							
Receiver sensitivity	-24.0 dBm							
Overload optical power	-9.0 dBm							
Extinction ratio	8.2 dB							

Table 5-98 Attributes of copper modules

Attribute	Description
Connector	RJ45
Standards compliance	IEEE802.3ab
Frame format	Ethernet_II, Ethernet_SAP, or Ethernet_SNAP
Network protocol	IP

- The attributes of the 10GE interfaces and connected optical modules.

Table 5-99 Interface attributes of an optical interface line card (10G Base-XFP)

Attribute	Description
Connector	LC/PC
Optical interface attribute	Determined by the SFP optical module. For details about the attributes of the SFP optical module, see Table 5-100 .
Standards compliance	IEEE 802.3ae
Frame format	Ethernet_II, Ethernet_SAP, Ethernet_SNAP
Network protocol	IP

Table 5-100 Attributes of an XFP optical module (10 Gbit/s)

Attribute	Description			
Transmission distance	300 m	10 km	40 km	80 km
Center wavelength	850 nm	1310 nm	1550 nm	1550 nm
Transmit power	-7.3 dBm to -1.3 dBm	-6.0 dBm to -1.0 dBm	-1.0 dBm to 2.0 dBm	0 dBm to 4.0 dBm
Receiver sensitivity	-7.5 dBm	-11.0 dBm	-15.0 dBm	-24.0 dBm
Overload optical power	-1.0 dBm	0.5 dBm	-1.0 dBm	-7.0 dBm
Extinction ratio	3.0 dB	6.0 dB	8.2 dB	9.0 dB

Attribute	Description	
Fiber type	Multi-mode	Single-mode

5.16.6 Technical Specifications

Table 5-101 describes the technical specifications of an S24XA board.

Table 5-101 Technical specifications of an S24XA board

Parameter	Description
Dimensions (depth x width x height)	426.8 mm x 394.7 mm x 35.1 mm
Power consumption	S24XA: 65 W
Weight	S24XA: 2.4 kg
Long-term temperature	0°C to 45°C
Short-term temperature	-5°C to 55°C

5.17 T24XA - 24-Port 10/100/1000BASE-T and 2-Port 10GBASE-X Interface Card(EA,RJ45/XFP)

This section describes the 24-Port 10/100/1000BASE-T and 2-Port 10GBASE-X Interface Card (EA,RJ45/XFP), including the appearance, functions and features, panel, interface attributes, and technical specifications.

5.17.1 Introduction

The 24-port 10M/100M/1000M Ethernet electrical and 2-port 10GE optical interface line card (EA, RJ45/XFP) is called T24XA and provides 24 GE electrical interfaces and 2 10GE optical interfaces.

5.17.2 Function and Application

Function

The T24XA provides 24 GE electrical interfaces and two 10GE optical interfaces to implement data access and line-speed switching.

Application

The T24XA can be installed in any LPU slot of the S7712, S7706, or S7703.

5.17.3 Panel

Figure 5-27 shows the appearance of the T24XA panel.

Figure 5-27 Appearance of the T24XA panel

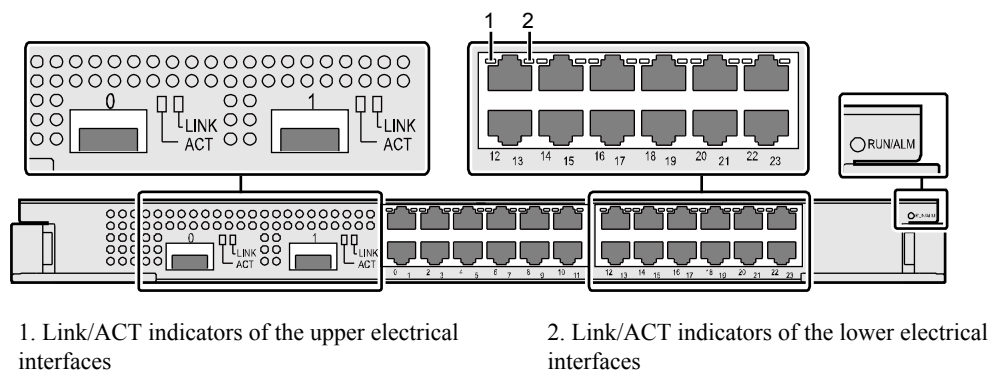

Buttons and Indicators on the Panel

Table 5-102 describes the buttons and indicators on the T24XA panel.

Table 5-102 Description of buttons and indicators on the T24XA panel

Indicator/Button	Color	Meaning
RUN/ALM	Green	If the indicator is on, it indicates that the board is powered on but the software is not running. If the indicator blinks once every 2s (0.5 Hz), it indicates that the system is in normal state. If the indicator blinks once every 0.25s (4 Hz), it indicates that the system is being powered on or being restarted.
	Red	If the indicator is in red, it indicates that the board is faulty.
	Orange	If the indicator is in orange, it indicates that the board is installed in the slot and the CBUS is powered on.
ACT	Amber	If the indicator blinks, it indicates that data is being transmitted.
LINK	Green-yellow	If the indicator is on, it indicates that the link is connected.

Indicator/Button	Color	Meaning
Link/ACT	Green	If the indicator is on, it indicates that the link is connected. If the indicator blinks, it indicates that data is being transmitted.

5.17.4 Interfaces

Table 5-103 describes the types and functions of the interfaces on the T24XA.

Table 5-103 Types and functions of the interfaces on the T24XA

Name	Quantity	Description
10M/100M/1000M BASE-T electrical interface	24	The T24XA provides 24 Ethernet electrical interfaces (10M/100M/1000M auto sensing) to transmit and receive Ethernet services at 1000 Mbit/s.
10G BASE-X optical interface	2	The T24XA provides two 10GE optical interfaces to transmit and receive Ethernet services at 10 Gbit/s.

5.17.5 Interface Attributes

The T24XA provides only data interfaces. Each interface has an optical module. The T24XA provides GE electrical interfaces and 10GE optical interfaces.

- **Table 5-104** lists the attributes of the 10M/100M/1000M Base-T electrical interface.

Table 5-104 Attributes of the 10M/100M/1000M Base-T Ethernet interface

Attribute	Description
Connector type	RJ45
Compliance standard	IEEE 802.3ab
Frame format	Ethernet_II, Ethernet_SAP, Ethernet_SNAP
Network protocol	IP

- **Table 5-105**, **Table 5-106**, **Table 5-107** and **Table 5-108** describe the attributes of the 10GE interfaces and the connected optical modules.

Table 5-105 Attributes of the 10G Base-XFP optical interface

Attribute	Description
Connector type	LC/PC
Optical interface attribute	Depending on the SFP optical module. For details about the attributes of the optical module, see Table 5-106 .
Compliance standard	IEEE 802.3ae
Frame format	Ethernet_II, Ethernet_SAP, or Ethernet_SNAP
Network protocol	IP

Table 5-106 Attributes of the XFP optical module (10 Gbit/s)

Attribute	Description			
Transmission distance	300 m	10 km	40 km	80 km
Center wavelength	850 nm	1310 nm	1550 nm	1550 nm
Transmitting power	-7.3 dBm to -1.3 dBm	-6.0 dBm to -1.0 dBm	-1.0 dBm to 2.0 dBm	0 dBm to 4 dBm
Receiver sensitivity	-7.5 dBm	-11.0 dBm	-15.0 dBm	-24.0 dBm
Overload optical power	-1.0 dBm	0.5 dBm	-1.0 dBm	-7.0 dBm
Fiber type	Multi-mode	Single-mode		

Table 5-107 Attributes of an XFP-CWDM optical module (10 Gbit/s)

Attribute	Description								
Transmission distance	70 km								
Center wavelength	1471 nm	1491 nm	1511 nm	1531 nm	1551 nm	1571 nm	1591 nm	1611 nm	

Attribute	Description
Transmit optical power	0 dBm to 3.0 dBm
Receiver sensitivity	-21.0 dBm
Overload optical power	-9.0 dBm
Extinction ratio	8.2 dB

Table 5-108 Attributes of an XFP-DWDM optical module (10 Gbit/s)

Attribute	Description							
Transmission distance	80 km							
Center wavelength	1529.55 nm	1530.33 nm	1531.12 nm	1531.90 nm	1532.68 nm	1533.47 nm	1534.25 nm	1535.04 nm
	1548.51 nm	1549.32 nm	1550.12 nm	1550.92 nm	1551.72 nm	1552.52 nm	1553.33 nm	1554.13 nm
Transmit optical power	-1.0 dBm to 3.0 dBm							
Receiver sensitivity	-24.0 dBm							
Overload optical power	-9.0 dBm							
Extinction ratio	8.2 dB							

5.17.6 Technical Specifications

Table 5-109 describes the technical specifications of the T24XA.

Table 5-109 Technical specifications of the T24XA

Item	Specification
Board dimensions (depth x width x height)	426.8 mm x 394.7 mm x 35.1 mm
Power consumption	53 W
Weight	2.30 kg
Long-term temperature	0°C to 45°C
Short-term temperature	-5°C to 55°C

5.18 G24S - 24-Port 100/1000BASE-X Interface Card (SFP)

This section describes the 24-Port 100/1000BASE-X Interface Card (SFP), including the appearance, functions and features, panel, interface attributes, and technical specifications.

5.18.1 Introduction

The 24-port 100M/1000M optical interface line card (SFP) of the S7700 is called G24S and has the following models: (SA, SFP) and (EC, SFP).

Table 5-110 lists the board full names and MAC address table capacities.

Table 5-110 G24S models

Full Name	Short Name	MAC Address Table Capacity
24-port 100/1000BASE-X interface line card (SA, SFP)	G24SA	32K
24-port 100/1000BASE-X interface line card (EC, SFP)	G24SC	128K

5.18.2 Function and Application

Function Description

The G24S provides 24 GE optical interfaces to implement data access and wire-speed switching.

Application

The G24S can be installed in any LPU slot on the S7712, S7706, or S7703.

5.18.3 Panel

Figure 5-28 and **Figure 5-29** show the appearances of the G24S panels.

Figure 5-28 Appearance of the G24SA panel

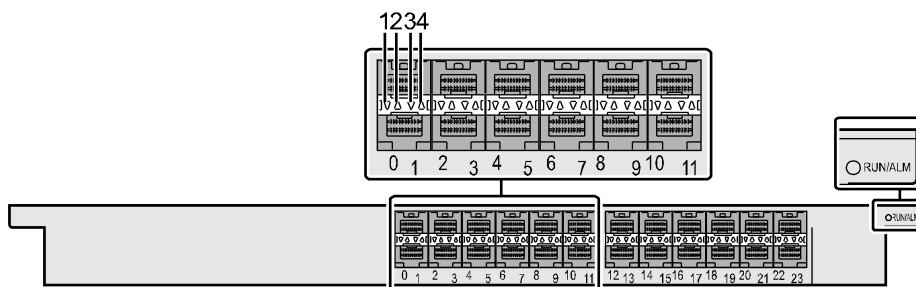

1. ACT indicators of the lower optical interfaces
2. ACT indicators of the upper optical interfaces
3. Link indicators of the lower optical interfaces
4. Link indicators of the upper optical interfaces

Figure 5-29 Appearance of the G24SC panel

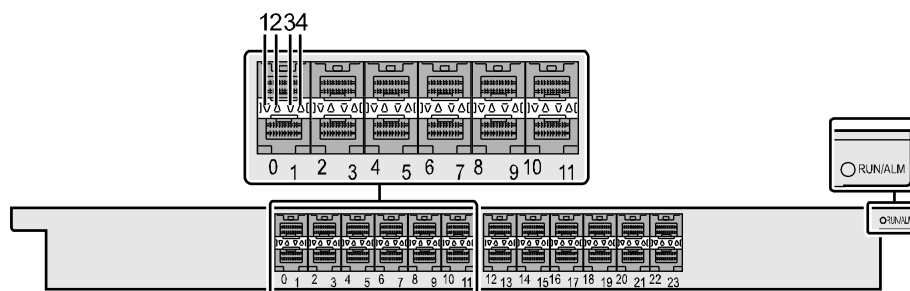

1. ACT indicators of the lower optical interfaces
2. ACT indicators of the upper optical interfaces
3. Link indicators of the lower optical interfaces
4. Link indicators of the upper optical interfaces

Buttons and Indicators on the Panel

Table 5-111 describes the buttons and indicators on the G24S panel.

Table 5-111 Description of buttons and indicators on the G24S panel

Indicator/Button	Color	Description
RUN/ALM	Green	If the indicator is on, it indicates that the LPU is powered on, but the software is not running. If the indicator blinks every 2s (0.5 Hz), it indicates that the system is running normally. If the indicator blinks every 0.25s (4 Hz), it indicates that the system is starting.
	Red	If the indicator is in red, it indicates that the LPU is faulty.
	Orange	If the indicator is in orange, it indicates that the LPU is installed, and the board is powered off.
ACT	Amber	If the indicator blinks, the data is being transmitted or received.
LINK	Green-yellow	If the indicator is on, it indicates that the link is connected.

5.18.4 Interfaces

Table 5-112 describes the types and functions of the interfaces on the G24S.

Table 5-112 Types and functions of the interfaces on the G24S

Name	Quantity	Description
100/1000BASE-X optical interface	24	The G24S provides 24 Ethernet optical interfaces (100M/1000M auto sensing) to transmit and receive 1000 Mbit/s Ethernet services.

5.18.5 Interface Attributes

The G24S has only the data interfaces. Each interface has an optical module.

Table 5-113 Interface attributes of the GE optical LPU (100M/1000M Base-SFP)

Attribute	Description
Connector type	LC/PC
Optical interface attribute	Depending on the SFP optical module.

Attribute	Description
Compliance standard	IEEE 802.3z
Frame format	Ethernet_II, Ethernet_SAP, or Ethernet_SNAP
Network protocol	IP

Table 5-114 Attributes of the SFP optical module (GE)

Attribute	Description							
	500 m	10 km	10 km (single-mode bidirectional fiber)		40 km	40 km	80 km	100 km
Center wavelength	850 nm	1310 nm	Tx: 1310 nm Rx: 1490 nm	Tx: 1490 nm Rx: 1310 nm	1310 nm	1550 nm	1550 nm	1550 nm
Transmitting power	-9.5 dBm to -2.5 dBm	-9.0 dBm to -3.0 dBm	-9.0 dBm to -3.0 dBm	-9.0 dBm to -3.0 dBm	-5.0 dBm to 0 dBm	-5.0 dBm to 0 dBm	-2.0 dBm to 5.0 dBm	0 dBm to 5 dBm
Receiver sensitivity	-17.0 dBm	-20.0 dBm	-19.5 dBm	-19.5 dBm	-23 dBm	-22 dBm	-23.0 dBm	-30.0 dBm
Overload optical power	0 dBm	-3.0 dBm	-3.0 dBm	-3.0 dBm	-3.0 dBm	-3.0 dBm	-3.0 dBm	-9.0 dBm
Extinction ratio	9 dB	9 dB	6 dB	6 dB	9 dB	8.5 dB	9 dB	8 dB

Attribute	Description	
Fiber type	Multi-mode Modal bandwidth: 400Mkm Fiber diameter: 50 um	Single-mode

Table 5-115 Attributes of an ESFP-CWDM optical module (100 Mbit/s or 1000 Mbit/s)

Attribute	Description							
Transmission distance	80 km							
Center wavelength	1471 nm	1491 nm	1511 nm	1531 nm	1551 nm	1571 nm	1591 nm	1611 nm
Transmit optical power	0 dBm to 5.0 dBm							
Receiver sensitivity	-28.0 dBm							
Overload optical power	-9.0 dBm							
Extinction ratio	8.5 dB							

Table 5-116 Attributes of copper modules

Attribute	Description
Connector	RJ45
Standards compliance	IEEE802.3ab

Attribute	Description
Frame format	Ethernet_II, Ethernet_SAP, or Ethernet_SNAP
Network protocol	IP

5.18.6 Technical Specifications

Table 5-117 describes the technical specifications of the G24S.

Table 5-117 Technical specifications of the G24S

Item	Specification
Board dimensions (depth x width x height)	426.8 mm x 394.7 mm x 35.1 mm
Maximum power consumption	G24SA: 45 W G24SC: 63 W
Weight	G24SA: 2.22 kg G24SC: 2.66 kg
Long-term temperature	0°C to 45°C
Short-term temperature	-5°C to 55°C

5.19 G24TFA-24-Port 10/100/1000BASE-T Interface Card (FA,RJ45)

This section describes the 24-Port 10/100/1000BASE-T Interface Card(FA,RJ45), including the appearance, functions and features, panel, interface attributes, and technical specifications.

5.19.1 Introduction

The 24-Port 10/100/1000BASE-T Interface Card(FA,RJ45) is called G24TFA for short. The G24TFA provides twenty-four 10M/100M/1000M Ethernet electrical interfaces. It supports 32K MAC address entries.

5.19.2 Function and Application

Function

The G24TFA provides twenty-four 10M/100M/1000M Ethernet electrical interfaces to implement data access and line-speed switching.

G24TFA complies with Energy Efficient Ethernet (EEE), so it supports dynamic energy saving according to network traffic volume.

Application

The G24TFA can be installed in any LPU slot of the S7712, S7706, or S7703.

5.19.3 Panel

Figure 5-30 shows the appearance of the G24TFA panel.

Figure 5-30 Appearance of the G24TFA panel

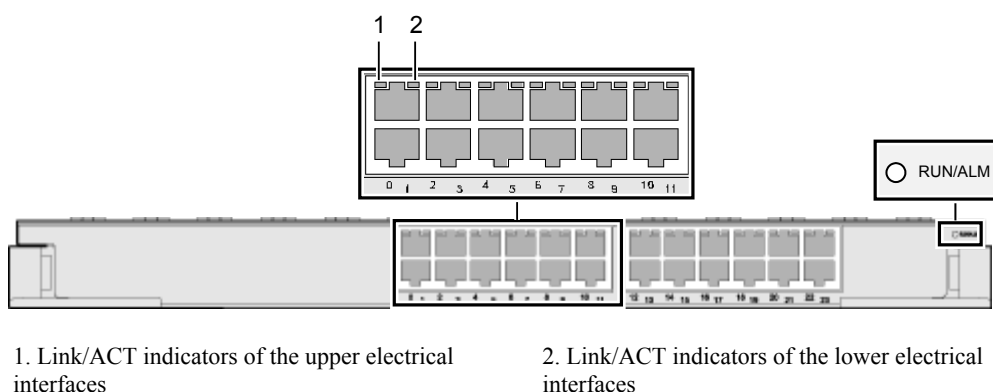

1. Link/ACT indicators of the upper electrical interfaces

2. Link/ACT indicators of the lower electrical interfaces

Buttons and Indicators on the Panel

Table 5-118 describes the indicators on the G24TFA panel.

Table 5-118 Description of indicators on the G24TFA panel

Indicator	Color	Description
RUN/ALM	Green	<ul style="list-style-type: none"> ● If the indicator is on, it indicates that the board is powered on, but the software is not running. ● If the indicator blinks once every 2s (0.5 Hz), it indicates that the system is in normal state. ● If the indicator blinks once every 0.25s (4 Hz), it indicates that the system is being powered on or being restarted.

Indicator	Color	Description
	Red	If the indicator is on, it indicates that the board is faulty.
	Orange	If the indicator is in orange, it indicates that the board is installed in a slot and the CBUS is powered on.
ACT/Link	Green	<ul style="list-style-type: none"> ● If the indicator blinks, data is being transmitted or received. ● If the indicator is on, it indicates that the link is connected.

5.19.4 Interfaces

Table 5-119 describes the types and functions of the interfaces on the G24TFA.

Table 5-119 Types and functions of the interfaces on the G24TFA

Name	Quantity	Description
10M/100M/1000M BASE-T Ethernet electrical interface	24	The G24TFA provides 24 10M/100M/1000M BASE-T Ethernet electrical interfaces to transmit and receive Ethernet services at 1000 Mbit/s.

5.19.5 Interface Attributes

The G24TFA provides only data interfaces.

Table 5-120 Attributes of the 10M/100M/1000M Base-T Ethernet interface

Attribute	Description
Connector type	RJ45
Compliance standard	IEEE 802.3ab, IEEE802.3AZ
Frame format	Ethernet_II, Ethernet_SAP, Ethernet_SNAP
Network protocol	IP

5.19.6 Technical Specifications

Table 5-121 describes the technical specifications of the G24TFA.

Table 5-121 Technical specifications of the G24TFA

Item	Specification
Dimensions (depth x width x height)	426.8 mm x 394.7 mm x 35.1 mm
Maximum power consumption	32 W
Weight	2.20 kg
Long-term temperature	0°C to 45°C
Short-term temperature	-5°C to 55°C

5.20 X12SA - 12-Port 10GE Optical Interface Card (SA, SFP+)

This section describes the 12-port 10GE optical interface card (SA, SFP+), including the appearance, functions and features, applicable device, slot, panel, indicators, interfaces, and technical specifications.

5.20.1 Introduction

The 12-port 10GE optical interface card (SA, SFP+) is called X12SA for short. The X12SA features high interface density, providing 12 10GE interfaces.

5.20.2 Function and Application

Function

An X12SA LPU provides 12 10GE optical interfaces to implement data access and wire-speed switching.

Application

An X12SA board can be installed in any LPU slot of the S7712, S7706, or S7703.

NOTE

Wire-speed forwarding can be implemented regardless of which LPU slot on the S7703 and S7706 is used. Wire-speed forwarding can be implemented only when LPU slots 6 and 7 on the S7712 are used.

5.20.3 Panel

[Figure 5-31](#) shows the appearance of the X12SA panel.

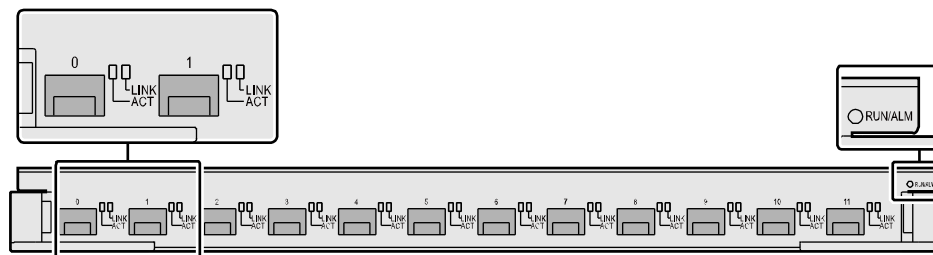
Figure 5-31 Appearance of the X12SA panel

Buttons and Indicators on the Panel

Table 5-122 describes the buttons and indicators on the X12SA panel.

Table 5-122 Description of buttons and indicators on the X12SA panel

Indicator/Button	Color	Meaning
RUN/ALM	Green	If the indicator is on, it indicates that the board is powered on but the software is not running. If the indicator blinks once every 2s (0.5 Hz), it indicates that the system is in normal state. If the indicator blinks once every 0.25s (4 Hz), it indicates that the system is being powered on or being restarted.
	Red	If the indicator is in red, it indicates that the board is faulty.
	Orange	If the indicator is in orange, it indicates that the board is installed in the slot and the CBUS is powered on.
ACT	Amber	If the indicator blinks, it indicates that data is being transmitted.
LINK	Green-yellow	If the indicator is on, it indicates that the link is connected.

5.20.4 Interfaces

Table 5-123 describes the types and functions of the interfaces on the X12SA.

Table 5-123 Types and functions of the interfaces on the X12SA

Name	Quantity	Description
10G BASE-X optical interface	12	The X12SA provides 12 10GE optical interfaces to transmit and receive Ethernet services at 10 Gbit/s.

5.20.5 Interface Attributes

[Table 5-124](#) and [Table 5-125](#) describe the attributes of the 10GE interfaces and the connected optical modules.

Table 5-124 Attributes of the 10G Base-SFP+ optical interface

Attribute	Description
Connector type	LC/PC
Optical interface attribute	Depending on the SFP optical module. For details about the attributes of the optical module, see Table 5-125 .
Compliance standard	IEEE 802.3ae
Frame format	Ethernet_II, Ethernet_SAP, or Ethernet_SNAP
Network protocol	IP

Table 5-125 Attributes of the SFP+ optical module (10 Gbit/s)

Attribute	Description		
Transmission distance	300 m	10 km	40 km
Center wavelength	850 nm	1310 nm	1550 nm
Transmitting power	-7.3 dBm to -1 dBm	-8.2 dBm to 0.5 dBm	-4.7 dBm to 4.0 dBm
Receiver sensitivity	-11.1 dBm	-12.6 dBm	-14.1 dBm
Overload optical power	-1.0 dBm	0.5 dBm	-1.0 dBm
Extinction ratio	3 dB	3.5 dB	3 dB
Fiber type	Multi-mode	Single-mode	

5.20.6 Technical Specifications

Table 5-126 describes the technical specifications of the X12SA.

Table 5-126 Technical specifications of the X12SA

Item	Specification
Board dimensions (depth x width x height)	426.8 mm x 394.7 mm x 35.1 mm
Power consumption	85 W
Weight	2.30 kg
Long-term temperature	0°C to 45°C
Short-term temperature	-5°C to 55°C

5.21 X4UX - 4-Port 10GBASE-X Interface Card (XFP)

This section describes the 4-Port 10GBASE-X Interface Card (EA, XFP) and 4-Port 10GBASE-X Interface Card (EC, XFP), including the appearance, functions and features, panel, interface attributes, and technical specifications.

5.21.1 Introduction

The 4-port 10GE optical interface line card (XFP) of the S7700 is called X4UX and has the following models: (ED, XFP), (EA, XFP) and (EC, XFP).

Table 5-127 lists the board full names and MAC address table capacities.

Table 5-127 X4UX models

Full Name	Short Name	MAC Address Table Capacity
4-port 10GBASE-X interface line card (EA, XFP)	X4UXA	32K
4-port 10GBASE-X interface line card (EC, XFP)	X4UXC	128K
4-port 10GBASE-X interface line card (ED, XFP)	X4UXD	512K

5.21.2 Function and Application

Function Description

The X4UX provides four 10GE optical interfaces to implement data access and wire-speed switching.

Application

The X4UX can be installed in any LPU slot on the S7712, S7706, or S7703.

5.21.3 Panel

Figure 5-32 shows the appearance of the X4UX panel.

Figure 5-32 Appearance of the panel of the X4UX

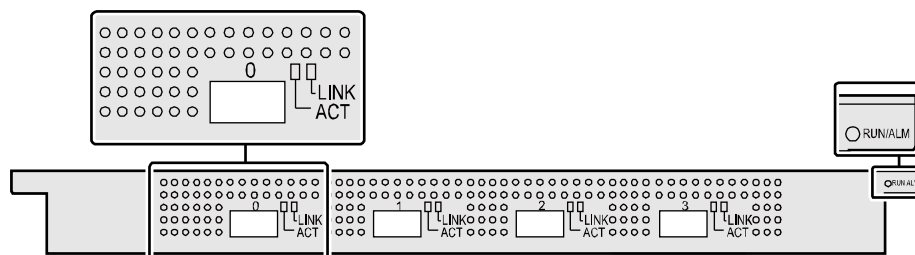

Buttons and Indicators on the Panel

Table 5-128 describes the buttons and indicators on the X4UX panel.

Table 5-128 Description of buttons and indicators on the Panel

Indicator/Button	Color	Description
RUN/ALM	Green	If the indicator is on, it indicates that the LPU is powered on, but the software is not running. If the indicator blinks every 2s (0.5 Hz), it indicates that the system is running normally. If the indicator blinks every 0.25s (4 Hz), it indicates that the system is starting.
	Red	If the indicator is in red, it indicates that the LPU is faulty.
	Orange	If the indicator is in orange, it indicates that the LPU is installed, and the board is powered off.

Indicator/Button	Color	Description
ACT	Amber	If the indicator blinks, the data is being transmitted or received.
LINK	Green-yellow	If the indicator is on, it indicates that the link is connected.

5.21.4 Interfaces

Table 5-129 describes the types and functions of the interfaces on the X4UX.

Table 5-129 Types and functions of the interfaces on the X4UX

Name	Quantity	Description
10G BASE-X optical interface	4	The X4UX provides four 10GE BASE-X optical interfaces to transmit and receive 10 Gbit/s Ethernet services.

5.21.5 Interface Attributes

The X4UX has only the data interfaces. Each interface has an optical module. **Table 5-130**, **Table 5-131**, **Table 5-132** and **Table 5-133** show the attributes of the interfaces and the optical modules on the X4UX.

Table 5-130 Attributes of the 10G Base-XFP optical interface

Attribute	Description
Connector type	LC/PC
Optical interface attribute	Depending on the optical module.
Compliance standard	IEEE 802.3ae
Frame format	Ethernet_II, Ethernet_SAP, or Ethernet_SNAP
Network protocol	IP

Table 5-131 Attributes of the XFP optical module (10 Gbit/s)

Attribute	Description			
Transmission distance	300 m	10 km	40 km	80 km
Center wavelength	850 nm	1310 nm	1550 nm	1550 nm
Transmitting power	-7.3 dBm to -1.3 dBm	-6.0 dBm to -1.0 dBm	-1.0 dBm to 2.0 dBm	0 dBm to 4 dBm
Receiver sensitivity	-7.5 dBm	-11.0 dBm	-15.0 dBm	-24.0 dBm
Overload optical power	-1.0 dBm	0.5 dBm	-1.0 dBm	-7.0 dBm
Extinction ratio	3.0 dB	6.0 dB	8.2 dB	9.0 dB
Fiber type	Multi-mode	Single-mode		

Table 5-132 Attributes of an XFP-CWDM optical module (10 Gbit/s)

Attribute	Description							
Transmission distance	70 km							
Center wavelength	1471 nm	1491 nm	1511 nm	1531 nm	1551 nm	1571 nm	1591 nm	1611 nm
Transmit optical power	0 dBm to 3.0 dBm							
Receiver sensitivity	-21.0 dBm							
Overload optical power	-9.0 dBm							
Extinction ratio	8.2 dB							

Table 5-133 Attributes of an XFP-DWDM optical module (10 Gbit/s)

Attribute	Description								
Transmission distance	80 km								
Center wavelength	1529.5 5 nm	1530.3 3 nm	1531.1 2 nm	1531.9 0 nm	1532.6 8 nm	1533.4 7 nm	1534.2 5 nm	1535.0 4 nm	
	1548.5 1 nm	1549.3 2 nm	1550.1 2 nm	1550.9 2 nm	1551.7 2 nm	1552.5 2 nm	1553.3 3 nm	1554.1 3 nm	
Transmit optical power	-1.0 dBm to 3.0 dBm								
Receiver sensitivity	-24.0 dBm								
Overload optical power	-9.0 dBm								
Extinction ratio	8.2 dB								

5.21.6 Technical Specifications

Table 5-134 describes the technical specifications of the X4UX.

Table 5-134 Technical specifications of the X4UX

Item	Specification
Board dimensions (depth x width x height)	426.8 mm x 394.7 mm x 35.1 mm
Maximum power consumption	X4UXA: 64 W X4UXC: 75 W X4UXD: 76 W
Weight	X4UXA: 2.16 kg X4UXC: 2.28 kg X4UXD: 2.30 kg
Long-term temperature	0°C to 45°C

Item	Specification
Short-term temperature	-5°C to 55°C

5.22 X2UX - 2-Port 10GBASE-X Interface Card (XFP)

This section describes the 2-Port 10GBASE-X Interface Card (EA, XFP) and 2-Port 10GBASE-X Interface Card (EC, XFP), including the appearance, functions and features, panel, interface attributes, and technical specifications.

5.22.1 Introduction

The 2-port 10GE optical interface line card (XFP) of the S7700 is called X2UX and has the following models: (EA, XFP) and (EC, XFP).

[Table 5-135](#) lists the board full names and MAC address table capacities.

Table 5-135 X2UX models

Full Name	Short Name	MAC Address Table Capacity
2-port 10GBASE-X interface line card (EA, XFP)	X2UXA	32K
2-port 10GBASE-X interface line card (EC, XFP)	X2UXC	128K

5.22.2 Function and Application

Function Description

X2UX provides two 10GE optical interfaces to implement data access and wire-speed switching.

Application

X2UX can be installed in any LPU slot of the S7712, S7706, and S7703.

5.22.3 Panel

[Figure 5-33](#) shows the appearance of an X2UX panel.

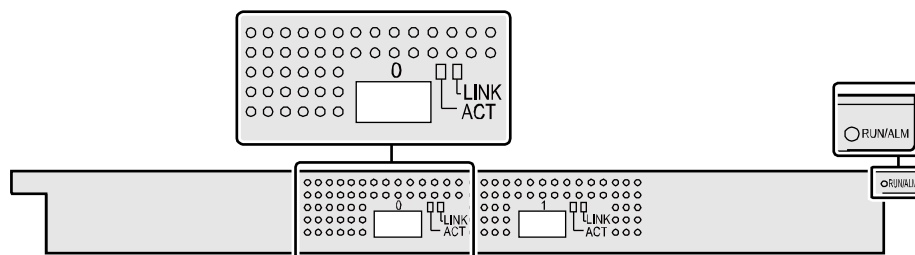
Figure 5-33 Appearance of an X2UX panel

Buttons and Indicators on a Panel

Table 5-136 describes the buttons and indicators on an X2UX panel.

Table 5-136 Buttons and indicators on an X2UX panel

Indicator/Button	Color	Description
RUN/ALM	Green	If the indicator is on, the board is powered on, but the software is not running. If the indicator blinks once every 2s (0.5 Hz), the system is running properly. If the indicator blinks once every 0.25s (4 Hz), the system is starting.
	Red	If the indicator is steady red, the board is faulty.
	Orange	If the indicator is steady orange, the board is installed and powered off.
ACT	Amber	If the indicator blinks, data is being transmitted or received.
LINK	Green-yellow	If the indicator is on, the link is connected.

5.22.4 Interfaces

Table 5-137 describes the types and functions of the interfaces on the X2UX.

Table 5-137 Types and functions of the interfaces on the X2UX

Name	Quantity	Description
10G BASE-X optical interface	2	The X2UX provides two 10GE BASE-X optical interfaces to transmit and receive 10 Gbit/s Ethernet services.

5.22.5 Interface Attributes

The X2UX has only the data interfaces. Each interface has an optical module. [Table 5-138](#), [Table 5-139](#), [Table 5-140](#) and [Table 5-141](#) show the attributes of the interfaces and the optical modules on the X2UX.

Table 5-138 Attributes of the 10G Base-XFP optical interface

Attribute	Description
Connector type	LC/PC
Optical interface attribute	Depending on the optical module.
Compliance standard	IEEE 802.3ae
Frame format	Ethernet_II, Ethernet_SAP, or Ethernet_SNAP
Network protocol	IP

Table 5-139 Attributes of the XFP optical module (10 Gbit/s)

Attribute	Description			
Transmission distance	300 m	10 km	40 km	80 km
Center wavelength	850 nm	1310 nm	1550 nm	1550 nm
Transmitting power	-7.3 dBm to -1.3 dBm	-6.0 dBm to -1.0 dBm	-1.0 dBm to 2.0 dBm	0 dBm to 4 dBm
Receiver sensitivity	-7.5 dBm	-11.0 dBm	-15.0 dBm	-24.0 dBm
Overload optical power	-1.0 dBm	0.5 dBm	-1.0 dBm	-7.0 dBm
Extinction ratio	3.0 dB	6.0 dB	8.2 dB	9.0 dB
Fiber type	Multi-mode	Single-mode		

Table 5-140 Attributes of an XFP-CWDM optical module (10 Gbit/s)

Attribute	Description							
Transmission distance	70 km							
Center wavelength	1471 nm	1491 nm	1511 nm	1531 nm	1551 nm	1571 nm	1591 nm	1611 nm
Transmit optical power	0 dBm to 3.0 dBm							
Receiver sensitivity	-21.0 dBm							
Overload optical power	-9.0 dBm							
Extinction ratio	8.2 dB							

Table 5-141 Attributes of an XFP-DWDM optical module (10 Gbit/s)

Attribute	Description							
Transmission distance	80 km							
Center wavelength	1529.55 nm	1530.33 nm	1531.12 nm	1531.90 nm	1532.68 nm	1533.47 nm	1534.25 nm	1535.04 nm
	1548.51 nm	1549.32 nm	1550.12 nm	1550.92 nm	1551.72 nm	1552.52 nm	1553.33 nm	1554.13 nm
Transmit optical power	-1.0 dBm to 3.0 dBm							
Receiver sensitivity	-24.0 dBm							
Overload optical power	-9.0 dBm							

Attribute	Description
Extinction ratio	8.2 dB

5.22.6 Technical Specifications

Table 5-142 describes the technical specifications of the X2UX.

Table 5-142 Technical specifications of the X2UX

Item	Specification
Board dimensions (depth x width x height)	426.8 mm x 394.7 mm x 35.1 mm
Maximum power consumption	X2UXA: 52 W X2UXC: 61 W
Weight	X2UXA: 2.14 kg X2UXC: 2.26 kg
Long-term temperature	0°C to 45°C
Short-term temperature	-5°C to 55°C

6 Cables

About This Chapter

This chapter describes the DC power cables and AC power cables of the S7700, including the structures and technical specifications of DC power cables and AC power cables.

[6.1 DC Power Cable](#)

This section describes the structure and technical specifications of the DC power cables.

[6.2 AC Power Cable](#)

This section describes the structure and technical specifications of the AC power cables.

[6.3 Ground Cable](#)

This section describes the structure and technical specifications of the ground cables.

[6.4 Console Cable](#)

This section describes the structure and technical specifications of the Console cable.

[6.5 Ethernet Cable](#)

This section describes the structure and technical specifications of the Ethernet cables.

[6.6 Optical Fiber](#)

This section describes the structure and technical specifications of the optical fibers.

[6.7 Clock Cable](#)

This section describes the structure and technical specifications of the clock cables.

[6.8 Stack Cables](#)

This section describes the structure and technical specifications of the stack cables.

6.1 DC Power Cable

This section describes the structure and technical specifications of the DC power cables.

6.1.1 Introduction

The power cables of the S7700 include power cables in the cabinet and power cables out of the cabinet. The external power cables connect the power distribution cabinet to the power distribution box, and the internal power cables connect the power distribution box to the S7700 in the cabinet.

The internal DC power cables include a -48 V power cable and a power ground cable RTN. One end of an internal DC power cable is an OT terminal, which connects to the power supply. The other end is a cord end terminal, which connects to the power distribution box.

The external DC power cables include a -48 V power cable and a power ground cable RTN. One end of an external DC cable is an OT terminal, which connects to the power distribution box. The other end is generally an OT terminal, which connects to the power distribution cabinet.

6.1.2 Structure

Figure 6-1 shows the internal DC power cable that connects the power distribution box to the DC power supplies in the chassis.

Figure 6-1 Internal DC power cable for S7700

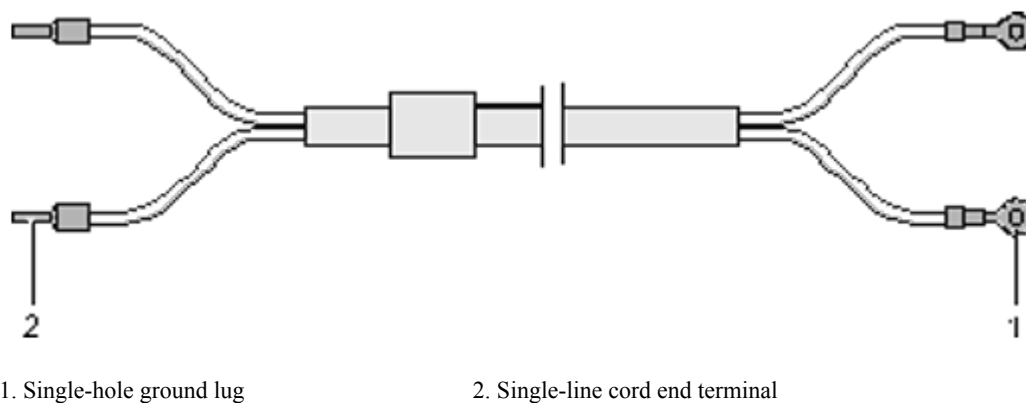

The terminals of the external DC power cable are determined according to the site survey.

6.1.3 Technical Specifications

Technical Specifications of the DC Power Cables in the Cabinet

Table 6-1 DC power cables in the cabinet

Item	Specification
-48 V power cable	Electronic and electrical cable-600 V-UL3386-5.2 mm ² -10AWG-Blue-48 A-Low-fume, halogenless and flame-retardant cable
RTN power cable	Electronic and electrical cable-600 V-UL3386-5.2 mm ² -10AWG-Black-48 A-Low-fume, halogenless and flame-retardant cable
Terminal connecting to the power modules of the S7700	Bare crimping terminal-OT-6 mm ² -M4-Tin plating-Round pre-Insulated terminal-12-10 AWG-Yellow
Terminal connecting to the power distribution box	Common terminal-Single-line cord end terminal-6 mm ² -0.02 m-30 A-Insert depth 12 mm-Black

Technical Specifications of the DC Power Cables Out of the Cabinet

Table 6-2 External DC power cables in different cabinet configuration schemes of S7700

Total Power Consumption	Description			
	Less than 1600 W	Power distance	35.6 m	55.6 m
Cross-sectional area of the conductor		16 mm ²	25 mm ²	35 mm ²
Power cable		Electronic and electrical cable-227IEC02 (RV)-16 mm ² -(blue, black, red, or green-yellow)	Electronic and electrical cable-227IEC02 (RV)-25 mm ² -(blue, black, red, or green-yellow)	Electronic and electrical cable-227IEC02 (RV)-35 mm ² -(blue, black, red, or green-yellow)
Terminal		16 mm ² power cable terminal	25 mm ² power cable terminal	35 mm ² power cable terminal
Less than 2400 W	Power distance	23.7 m	37.0 m	51.8 m

Total Power Consumption	Description			
	Cross-sectional area of the conductor	16 mm ²	25 mm ²	35 mm ²
	Power cable	Electronic and electrical cable-227IEC02 (RV)-16 mm ² - (blue, black, red, or green-yellow)	Electronic and electrical cable-227IEC02 (RV)-25 mm ² - (blue, black, red, or green-yellow)	Electronic and electrical cable-227IEC02 (RV)-35 mm ² - (blue, black, red, or green-yellow)
	Terminal	16 mm ² power cable terminal	25 mm ² power cable terminal	35 mm ² power cable terminal
Less than 3200 W	Power distance	-	27.7 m	38.8 m
	Cross-sectional area of the conductor	-	25 mm ²	35 mm ²
	Power cable	-	Electronic and electrical cable-227IEC02 (RV)-25 mm ² - (blue, black, red, or green-yellow)	Electronic and electrical cable-227IEC02 (RV)-35 mm ² - (blue, black, red, or green-yellow)
	Terminal	-	25 mm ² power cable terminal	35 mm ² power cable terminal

6.2 AC Power Cable

This section describes the structure and technical specifications of the AC power cables.

6.2.1 Introduction

The power cables of the S7700 include:

- Internal power cables, which are in the chassis

- External power cables, which are outside the chassis

An external power cable transmits power from the user's power distribution frame to the power distribution box in the cabinet, and then an internal power cable transmits power from the power distribution box to the S7700 in the cabinet.

Internal power cables are classified into:

- AC power cables for 800 W power supply units
- AC power cables for 2200 W power supply units

Each internal or external AC power cable consists of the live wire, neutral wire, and ground cable.

6.2.2 Structure

NOTE

The appearances of the power cables for 800 W power supply unit and 2200 W power supply unit are the same, but the connectors of the cables are different:

- The power cables for the 800 W power supply units use the C13-straight-female connectors.
- The power cables for the 2200 W power supply units use the C19-straight-female connectors.

[Figure 6-2](#) shows the appearance of the internal AC power cables.

Figure 6-2 Appearance of the internal AC power cables



The terminals of the external AC power cables are determined according to the site survey.

6.2.3 Technical Specifications

[Table 6-3](#), [Table 6-4](#) and [Table 6-5](#) show the technical specifications of the AC power cables of the S7700.

Table 6-3 Technical specifications of the power cables for 800 W AC power supply units

Item	Description
Power cable	220 V 10 A AC power cable

Item	Description
Connector	C13-straight-female
Color	Black
Cable length	3 meters
Conductor cross-sectional area	3*1.0 mm ²
Cable type	227 IEC 53-1.0 ² (3C)

Table 6-4 Technical specifications of the power cables for 2200 W AC power supply units

Item	Description
Power cable	220 V 16 A AC power cable
Connector	C19-straight-female
Color	Black
Cable length	3 meters
Cable type	227 IEC 53-2.5 ² (3C)

Table 6-5 Technical specifications of the AC power cables out of the cabinet

Item	Description
Power cable	Electronic and electrical cable-300 V-227IEC10(BVV)-6 mm ² -Black jacket (core: blue, brown, yellow/green)-36 A-3 cores with equal cross sections
Terminal	35 mm ² power cable terminal

6.3 Ground Cable

This section describes the structure and technical specifications of the ground cables.

6.3.1 Introduction

The ground cables connect the S7700 and cabinet to the ground. The ground cables in the front, rear, and side panels of the cabinet have been properly connected before delivery.

6.3.2 Structure

The appearance of ground cable terminals and the DC power cable terminals is the same.

6.3.3 Technical Specifications of the Ground Cables

Table 6-6 shows the technical specifications of the ground cables of the cabinet.

Table 6-6 Technical specifications of the S7700 ground cables

Item	Specification
Cable	Electronic and electrical cable-450V/750V-H07Z-K-6 mm ² -Yellow-green-Low-fume, halogenless and flame-retardant cable
Terminal	Bare crimping terminal-OT-6 mm ² -M6-Tin plating-Round pre-insulated terminal-12 to 10 AWG-Yellow

6.4 Console Cable

This section describes the structure and technical specifications of the Console cable.

6.4.1 Introduction

The Console cable is used to connect the S7700 Console port to the serial port of the Console to transmit the configuration data of the S7700.

You can select the shielded cable or unshielded cable according to the actual situation. One end of the cable is an RJ45 connector that is connected to the Console port of the main control board, and the other end that is connected to the serial port of the computer has a DB9 connector and a DB25 connector. Either of the two connectors can be selected to connect to the serial port according to the actual situation.

6.4.2 Structure

Figure 6-3 shows the Console cable, and **Table 6-7** shows the connection of the Console cable.

Figure 6-3 Console cable

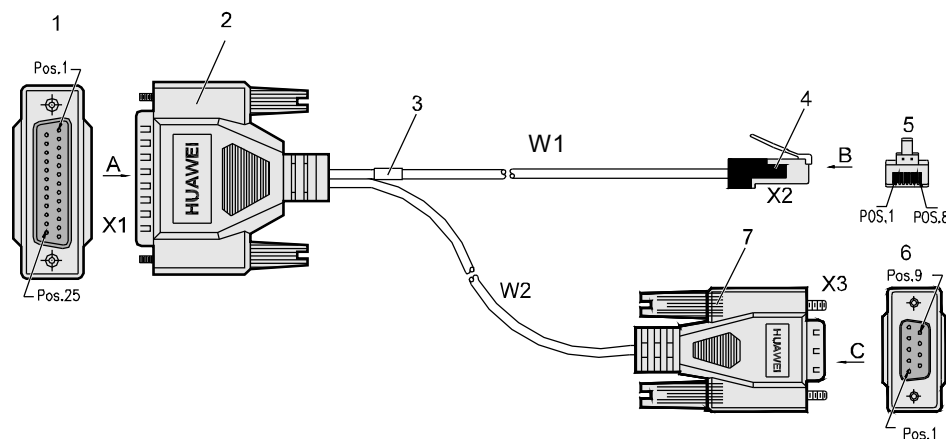

- 1. Direction A 2. DB25 plug 3. Label 4. Network port connector RJ45
- 5. Direction B 6. Direction C 7. DB9 plug W1 and W2 communication cables

Table 6-7 Pin assignments of the Console cable

RJ45	Direction	DB25	DB9	Signal
1	--->	5	8	Clear to Send (CTS)
2	--->	6	6	Data Set Ready (DSR)
3	--->	3	2	Receive Data (RXD)
4	-	7	5	GND
5	-	7	5	GND
6	<---	2	3	Transmit Data (TXD)
7	<---	20	4	Data Terminal Ready (DTR)
8	<---	4	7	Request to Send (RTS)

6.4.3 Technical Specifications

Table 6-8 describes the technical specifications of the Console cable.

Table 6-8 Technical specifications of the Console cable

Item	Specification
Connector X1	Cable connector-D style-25PIN-Plug

Item	Specification
Connector X2	Network interface connector-Crystal connector-8PIN-8 bits-Connector
Connector X3	Cable connector-D style-9PIN-Plug
Fire-resistance	CM

6.5 Ethernet Cable

This section describes the structure and technical specifications of the Ethernet cables.

6.5.1 Introduction

Ethernet cables are classified into the straight-through cable and the crossover cable.

Straight-through Cable

The straight-through cable is used to connect the Ethernet interfaces between the following devices:

- Router and hub
- Router and LAN switch
- PC and LAN switch
- PC and hub

Crossover Cable

The crossover cable is used to connect the Ethernet interfaces between the following devices:

- Router and router
- Router and PC
- Hub and hub
- Hub and switch
- Switch and switch
- PC and PC

6.5.2 Structure

The straight-through cable and the crossover cable are standard unshielded network cables. They adopt the RJ45 connectors, and [Figure 6-4](#) shows the structure of an RJ45 connector.

Figure 6-4 Structure of RJ45

Table 6-9 describes pin assignments of the straight-through cable. **Table 6-10** describes pin assignments of the crossover cable.

Table 6-9 Pin assignments of the straight-through cable

Connector X1	Connector X2	Color	Relation
X1.2	X2.2	Orange	Pair
X1.1	X2.1	White/Orange	
X1.6	X2.6	Green	Pair
X1.3	X2.3	White/Green	
X1.4	X2.4	Blue	Pair
X1.5	X2.5	White/Blue	
X1.8	X2.8	Brown	Pair
X1.7	X2.7	White/Brown	

Table 6-10 Pin assignments of the crossover cable

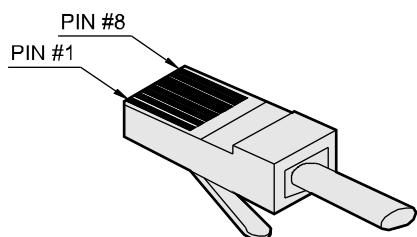
Connector X1	Connector X2	Color	Relation
X1.6	X2.2	Orange	Pair
X1.3	X2.1	White/Orange	
X1.2	X2.6	Green	Pair
X1.1	X2.3	White/Green	
X1.4	X2.4	Blue	Pair
X1.5	X2.5	White/Blue	
X1.8	X2.8	Brown	Pair

Connector X1	Connector X2	Color	Relation
X1.7	X2.7	White/Brown	

6.5.3 Technical Specifications

Table 6-11 describes the technical specifications of the straight-through cable. **Table 6-12** describes the technical specifications of the crossover cable.

Table 6-11 Technical specifications of the straight-through cable

Item	Specification
Connector X1/X2	Network interface connector-Crystal connector-8PIN-8 bits-Shield-Plug-24 to 26 AWG-CAT 6/SFTP network cable
Power cable	Communication cable-100±15 non-shield enhanced 5 types-CAT5E SFTP 24 AWG-8-core PANTONE 445 U
Number of cores	8 cores
Fire-resistance	CM
Length	5 m, 10 m, 20 m, or 30m

Table 6-12 Technical specifications of the crossover cable

Item	Specification
Connector X1/X2	Network interface connector-Crystal connector-8PIN-8 bits-Shield-Plug-24 to 26 AWG-CAT 6/SFTP network cable
Power cable	Communication cable-100±15 non-shield enhanced 5 types-CAT5E SFTP 24 AWG-8-core PANTONE 646 U
Number of cores	8 cores
Fire-resistance	CM
Length	5 m or 30 m

6.6 Optical Fiber

This section describes the structure and technical specifications of the optical fibers.

6.6.1 Introduction

Optical fibers are classified into single-mode and multimode fibers.

Single-mode fibers have a diameter of 5-10 μm and transmit laser in one mode under a specified wavelength. These fibers support a wide frequency band and a large transmission capacity, so they are used for long-distance transmission. Most single-mode fibers are yellow.

Multimode fibers have a diameter of 50 μm or 62.5 μm and transmit laser in multiple modes under a specified wavelength. These fibers have a lower transmission capacity than single-mode fibers and are used for short-distance transmission. Most multimode fibers are orange. [Table 6-13](#) shows parameters of multimode fibers.

Table 6-13 Parameters of multimode fibers

Transmission speed (Gbit/s)	Maximum Transmission Distance (m)	Modal Bandwidth (MHz × km)	Diameter (μm)	Class
0.1	2000	-	62.5/125	-
1	500	400	50/125	-
10	300	2000	50/125	-
			62.5/125	-
	220	500	62.5/125	OM1
			50/125	OM2
			50/125	OM3

[Table 6-14](#) provides the types of optical fibers used by the S7700.

Table 6-14 Types of the optical fibers

No.	Cable and Use	Local Connector	Remote Connector	Cables
1	Fiber connecting the local LPU to the ODF	LC/PC	FC/PC	Single mode
2	Fiber connecting to the local LPUs	LC/PC	LC/PC	Single mode/ multimode
3	Fiber connecting the local LPU to the other equipment	LC/PC	SC/PC or LC/ PC	Single mode/ multimode

 **NOTE**

An optical module of the multi-longitudinal mode needs to be connected to a multimode or single-mode fiber. An optical module of the single-longitudinal mode needs to be connected to a single-mode fiber.

It is recommended that you connect single-mode fibers to single-mode optical modules and multi-mode fibers to multi-mode optical modules.

6.6.2 Optical Connector

The S7700 uses the LC/PC optical connector.

Figure 6-5 shows the appearance of the LC/PC optical connector.

Figure 6-5 Appearance of the LC/PC optical connector

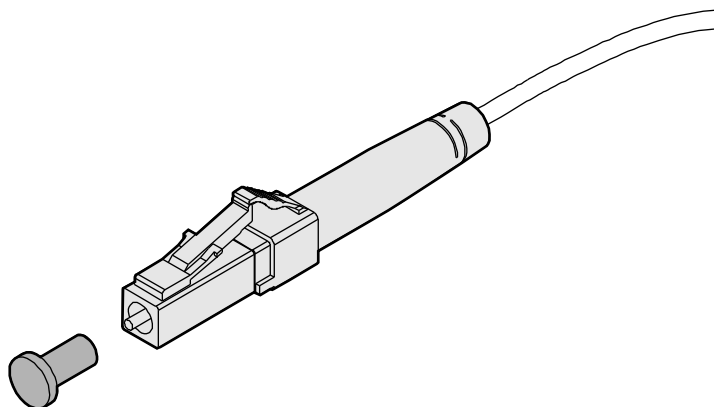

CAUTION

The plugging/unplugging of the LC/PC optical interface needs only an axial operation instead of a rotation. The operation procedures and precautions are as follows:

- Align the head of the fiber jumper with the optical interface on the optical board and exert proper force to push the fiber inside.
- Press the clip before pulling out the fiber. Push in the fiber connector inward slightly, and then pull out the connector.

6.6.3 Technical Specifications

Table 6-15 describes the technical specifications of the optical fiber.

Table 6-15 Technical specifications of the optical fiber

Item	Specification
Fiber transmission mode	Single mode/multimode
Connector	LC/PC
Outer diameter	2 mm

6.7 Clock Cable

This section describes the structure and technical specifications of the clock cables.

6.7.1 Introduction

The external synchronization interface of the S7700 is used for clock and time synchronization.

The S7700 can be connected to the external clock source or clock source device through the clock cable.

The clock cable is used to connect the S7700 with the clock interface of the external equipment. With the cable, the S7700 can receive 2-channel 2.048 MHz or 2.048 Mbit/s synchronous clock signals provided by the upstream device. The S7700 can also offer 2-channel 2.048 MHz or 2.048 Mbit/s synchronous clock signals to the downstream device.

When the S7700 is connected to the clock interface of the external equipment through the clock cable, the S7700 can receive the 2-channel TOD or DCLS synchronous clock signals provided by the upstream device. The S7700 can also offer 2-channel TOD or DCLS synchronous clock signals to the downstream device.

One end of the clock cable is the RJ45 connector, which is connected to the BITTS interface on the SRU of the S7700. The other end of the clock cable is connected to the external clock device. The connector type depends on the type of the external clock device. The external clock device connected to the S7700 can be the SubMiniature version B (SMB) clock source, Boyonet Neil Councilman (BNC) clock source, RJ45 clock source, and RJ45 time source.

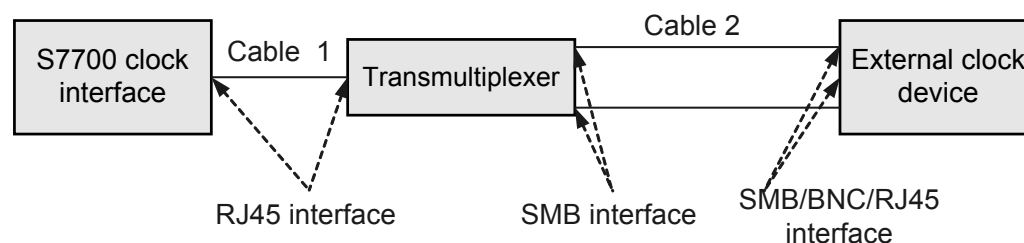
Figure 6-6 Clock cable connections

According to the functions and interface types of the external clock device connected to the S7700, the following cables can be selected:

- If the connected device is the clock source and the RJ45 interface is used:
Cable 1 can be the RJ48 cable. The transmultiplexer or cable 2 is not required.
- If the connected device is the clock source and the SMB interface is used:
Cable 1 can be the RJ45 cable, and cable 2 can be the SMB/SMB trunk cable. The transmultiplexer is required.
- If the connected device is the clock source and the SMB interface is used:
Cable 1 can be the RJ45 cable, and cable 2 can be the SMB/SMB trunk cable. The transmultiplexer is required.
- If the connected device is the time source and the RJ45 interface is used:
Cable 1 can be the RJ45 cable. The transmultiplexer or cable 2 is not required.



NOTE

Both the RJ48 cables and RJ45 cables must be shielded cables.

6.7.2 Structure

RJ48 Cable

The RJ48 cable supported by the S7700 is the 120Ω trunk cable (shielded cable), as shown in [Figure 6-7](#).

Figure 6-7 Structure of the 120Ω trunk cable

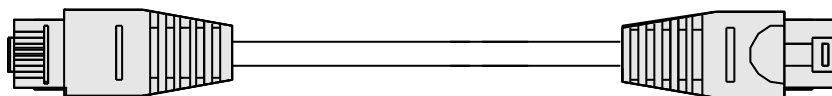

NOTE

When the connected device is RJ45 clock source, the RJ48 cables are used for the connection of S7700 and the RJ45 clock source.

RJ45 Cable

The RJ45 cable supported by the S7700 is the straight-through cable (shielded cable), as shown in [Figure 6-8](#).

Figure 6-8 Structure of the straight-through cable

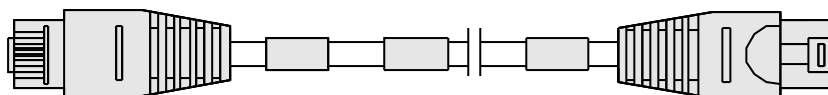

NOTE

When the connected device is RJ45 time source, the RJ45 cables is used for the connection of S7700 and the RJ45 time source.

When the connected device is SMB clock source or BNC clock source, the RJ45 cable is used for the connection of S7700 and transmultiplexer.

SMB/SMB Trunk Cable

The SMB/SMB trunk cable is the 75Ω trunk cable with the SMB connectors, as shown in [Figure 6-9](#).

Figure 6-9 SMB/SMB trunk cable

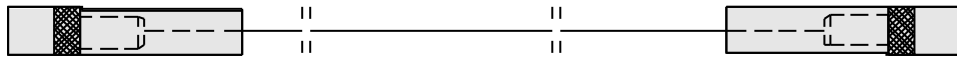

SMB/BC Trunk Cable

The SMB/BNC trunk cable is the 75Ω trunk cable with the SMB connector and BNC connector, as shown in [Figure 6-10](#).

Figure 6-10 SMB/BNC trunk cable

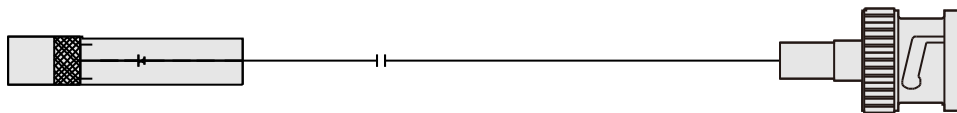

6.7.3 Technical Specifications

120 Ω Trunk cable

Cable Description	Length
Trunk cable-3.00 m-120 ohm-1E1-0.4 mm-(8-bit network interface-II)-(120CC4P0.4P430U(S))-(8-bit network interface-II)-Expert	3 m
Trunk cable-15 m-120 ohm-1E1-0.4 mm-(8-bit network interface-II)-(120CC4P0.4P430U(S))-(8-bit network interface-II)	15 m
Trunk cable-30.00 m-120 ohm-1E1-0.4 mm-(8-bit network interface-II)-(120CC4P0.4P430U(S))-(8-bit network interface-II)-Expert	30 m
Trunk cable-60.00 m-120 ohm-1E1-0.4 mm-(8-bit network interface-II)-(120CC4P0.4P430U(S))-(8-bit network interface-II)-Expert	60 m
Trunk cable-80.00 m-120 ohm-1E1-0.4 mm-(8-bit network interface-II)-(120CC4P0.4P430U(S))-(8-bit network interface-II)-Expert	80 m

Straight-Through Cable

Cable Description	Length
Single cable-MEM board network card-straight-through cable connecting Hub and computer-0.20 m-(8-bit network interface-I)-(CC4P0.5 gray)-(8-bit network interface-I)-C&C08B, DL2015	0.2 m
Single cable-straight-through network cable-0.50 m-(8-bit network interface-I)-(CC4P0.5 gray)-(8-bit network interface-I)-ONU-160B, DL5042	0.5 m
Single cable-straight-through cable-1 m-(8-bit network interface-I)-(CC4P0.5 gray)-(8-bit network interface-I)	1 m
Single cable-straight-through cable-1.50 m-(8-bit network interface-I)-(CC4P0.5 gray)-(8-bit network interface-I)	1.5 m
Single cable-straight-through cable-2.00 m-(8-bit network interface-I)-(CC4P0.5 gray)-(8-bit network interface-I), DL3470	2 m
Single cable-straight-through cable-3.00 m-(8-bit network interface-I)-(CC4P0.5 gray)-(8-bit network interface-I)	3 m
Single cable-straight-through cable-5.00 m-(8-bit network interface-I)-(CC4P0.5 gray)-(8-bit network interface-I), DL4538	5 m
Single cable-straight-through cable-10.00 m-(8-bit network interface-I)-(CC4P0.5 gray)-(8-bit network interface-I), DL2761	10 m
Single cable-straight-through cable-30.00 m-(8-bit network interface-I)-(CC4P0.5 gray)-(8-bit network interface-I), DL4217	30 m
Single cable-straight-through cable connecting Hub and computer-40.00 m-(8-bit network interface-I)-(CC4P0.5 gray)-(8-bit network interface-I)-PDH-HONET, DL4218	40 m
Single cable-straight-through cable connecting Hub and computer-60 m-(8-bit network interface-I)-(CC4P0.5 gray)-(8-bit network interface-I)-HONET, DL3702	60 m

SMB/SMB Trunk Cable

The type of the SMB/SMB trunk cable is: Trunk cable-2.00 m-75 ohm-2.2 mm-(SMB75SF-V)-(SYFVZ75-1.2/0.25)-(SMB75SF-V)-HONET, DL4362. The two ends of the cable are SMB connectors. The cable length is 2 m.

SMB/BNC Trunk Cable

The type of the SMB/BNC trunk cable is: Trunk cable-10.00 m-75 ohm-2.2 mm-(SMB75SF-V)-(SYFVZ75-1.2/0.25)-(BNC75SF-V)-STP. One end of the cable is the SMB connector, and the other end is the BNC connector. The cable length is 10 m.

6.8 Stack Cables

This section describes the structure and technical specifications of the stack cables.

6.8.1 Introduction

An S7700 can use QSFP high-speed cables or QSFP+ optical fibers as stack cables, which interconnect the interfaces on the VSTSA cards. The S7706 and S7712 switches are connected through the stack cables to form a logical switch, implementing packet forwarding.

 **NOTE**

The two ends of a stack cable must be covered by the ESD caps.

The Quad Small Form-Factor Pluggable (QSFP) is a 4-channel small hot pluggable optical module.

6.8.2 Structure

Figure 6-11 and **Figure 6-12** show the structures of the QSFP high-speed stack cables.

Figure 6-11 QSFP high-speed stack cable structure (1)

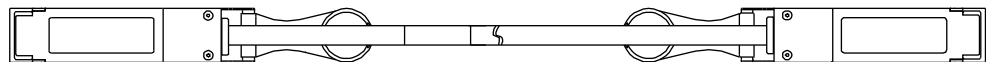

Figure 6-12 QSFP high-speed stack cable structure (2)

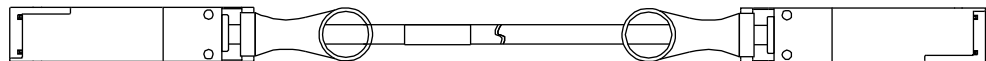
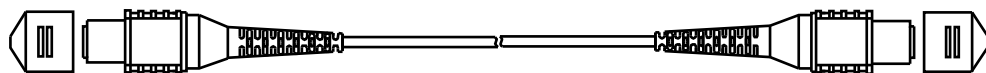

Figure 6-13 shows the structure of a QSFP+ optical fiber.

Figure 6-13 QSFP+ optical fiber structure



6.8.3 Technical Specifications

Table 6-16 lists the technical specifications of a QSFP high-speed cable.

Table 6-16 Technical specifications of a QSFP high-speed cable

Item	Description
Cable	QSFP high-speed cable-Indoor-(QSFP 38 male)-(QSFP 38 male)-(CC8P0.5 black (S))-15 m
Connector X1/X2	QSFP-38PIN-male
Fire-resistance	UL VW-1 (UL758) or CM (UL444) or CL2 (UL13) or FT4

Item	Description
Color	Black or Blue
Number of cores	8
Length	10 m
Bend radius	75 mm

Table 6-17 lists the technical specifications of a QSFP+ optical fiber used on the S7700.

Table 6-17 Technical specifications of a QSFP+ optical fiber

Fiber type	OM3	OM4
Length	100 m	150 m

7 List of Indicators

About This Chapter

This chapter describes the status and meanings of the indicators on the S7700, including the indicators of boards, fan modules, and power supplies.

[7.1 Fan Module Indicators](#)

This section describes the fan module indicators.

[7.2 Power Supply Indicators](#)

This section describes the power supply indicators.

[7.3 SRU Indicators](#)

This section describes the SRU indicators.

[7.4 MCUA Indicators](#)

This section describes the MCUA indicators.

[7.5 LPU Indicators](#)

This section describes the LPU indicators.

[7.6 CMU Indicators](#)

This section describes the CMU indicators.

7.1 Fan Module Indicators

This section describes the fan module indicators.

Table 7-1 describes the fan module indicators.

Table 7-1 Description of the fan module indicators

Name	Color	Description
RUN/ALM	Green	If the indicator blinks (0.5 Hz), it indicates that the fan module works normally, and the communication is normal. If the indicator blinks (4 Hz), it indicates that the fan module works normally, but the communication is abnormal.
	Red	If the indicator blinks (0.5 Hz), it indicates that an alarm is generated, but you cannot determine whether to replace the fan module. It is recommended that you check the situation for certain time. If the indicator is on, it indicates that the fan module is faulty and you need to replace them.

7.2 Power Supply Indicators

This section describes the power supply indicators.

DC power supply indicators are installed on the DC power supply panel through the light pipe.

Table 7-2 lists the indicators on a DC power supply panel.

Table 7-2 Indicators on a 1600 W DC power supply panel

Indicator	Color	Description
ALM	Red	If the indicator is on, the protection circuit fails. If the indicator is off, the protection circuit is working properly.
INPUT	Green	If the indicator is on, the -48 V power input is in the allowed range. If the indicator is off, the -48 V power input is unavailable.

Table 7-3 describes the AC power supply indicators.

Table 7-3 Indicators on an AC power supply

Indicator	Color	Description
RUN	Green	If the indicator is on, the AC power input is in the allowed range. If the indicator is off and the FAULT indicator or ALM indicator is on, a fault has occurred or an alarm other than the overcurrent alarm is generated.
ALM	Yellow	If the indicator is on, a PS-off alarm, overtemperature alarm, overvoltage alarm, undervoltage alarm, or overcurrent alarm is generated. If the indicator blinks, communication with the monitoring device MPU or CMU is interrupted. If the indicator is off, the power supply is working properly.
FAULT	Red	If the indicator is on, the power supply is faulty and cannot be rectified. If the indicator is off, the power supply has no such fault.

7.3 SRU Indicators

This section describes the SRU indicators.

[Table 7-4](#) describes the SRU indicators.

Table 7-4 Description of the buttons and indicators on the SRU panel

Indicator/Button	Color	Meaning
RUN/ALM	Green	If the indicator is on, it indicates that the SRU is powered on, but the software is not running. If the indicator blinks once every 2s (0.5 Hz), it indicates that the system is in normal state. If the indicator blinks once every 0.25s (4 Hz), it indicates that the system is being started.
	Red	If the indicator is in red, it indicates that the board is faulty.
	Orange	If the indicator is in orange, it indicates that the board is Steady on (both the red and green LEDs are on): installed in the slot and is powered off..

Indicator/Button	Color	Meaning
ACT	Green	This indicator shows whether the SRU is the master SRU or slave SRU. If the indicator is on, it indicates that the SRU is the master one. If the indicator is off, it indicates that the SRU is the standby one.
RST	-	Press this button to reset the board. NOTE Resetting the board will cause the loss of service packets. Confirm the operation before you press the Reset button.
SYNC	Green	If the indicator is on, it indicates that the device supports the time and clock synchronization and the clock board is installed on the SRU. If the indicator is off, it indicates that the device supports the time and clock synchronization but the clock board is not installed on the SRU.

7.4 MCUA Indicators

This section describes the MCUA indicators.

[Table 7-5](#) describes the MCUA indicators.

Table 7-5 Description of the MCUA indicators

Indicator/Button	Color	Description
RUN/ALM	Green	If the indicator is on, it indicates that the MCUA is powered on, and the software is not run. If the indicator blinks every 2s (0.5 Hz), it indicates that the system is in normal state. If the indicator blinks every 0.25s (4 Hz), it indicates that the system is starting.
	Red	If the indicator is in red, it indicates that the board is faulty.
	Orange	If the indicator is in orange, it indicates that the board is inserted in the subrack and is installed, and the board is powered off.

Indicator/Button	Color	Description
ACT	Green	Indicates the active MCUA or the standby MCUA. If the indicator is on, it indicates that the MCUA is the active one. If the indicator is off, it indicates that the MCUA is the standby one.
RST	-	Press this button to reset the board.

7.5 LPU Indicators

This section describes the LPU indicators.

Indicators on the Panel

Table 7-6 describes the indicators on the panel of the LPU.

Table 7-6 Description of the indicators on the panel of the LPU

Indicator/Button	Color	Description
RUN/ALM	Green	If the indicator is on, it indicates that the LPU is powered on, but the software is not running. If the indicator blinks every 2s (0.5 Hz), it indicates that the system is in normal state. If the indicator blinks every 0.25s (4 Hz), it indicates that the system is starting.
	Red	If the indicator is in red, it indicates that the board is faulty.
	Orange	If the indicator is in orange, it indicates that the board is inserted in the subrack and is installed, and the board is powered off.

Interface Indicators of the Optical LPU

Each interface provides two indicators. The left is the ACT indicator, and the right is the Link indicator. **Table 7-7** describes the meanings of the indicators.

Table 7-7 Interface indicators of the optical LPU

Indicator/Button	Color	Description
ACT	Amber	If the indicator blinks, the data is being transmitted or received. If the indicator is off, it indicates that no data is being transmitted or received.
LINK	Green-yellow	If the indicator is on, it indicates that the link is connected. If the indicator is off, it indicates that the link is broken or faulty.

Interface Indicators of the Electrical LPU

Each interface provides a green indicator. If the indicator is on, it indicates that it is the Link indicator; if the indicator blinks, it is the ACT indicator. For each group of interface numbers, the one on the left maps the upper interface, and the one on the right maps the lower interface. [Table 7-8](#) describes the indicators.

Table 7-8 Interface indicators of the electrical LPU

Indicator/Button	Color	Description
LINK/ACT	Green	If the indicator is on, it indicates that the link is connected. If the indicator blinks, the data is being transmitted or received. If the indicator is off, it indicates that the link is broken or faulty.

7.6 CMU Indicators

This section describes the CMU indicators.

[Table 7-9](#) describes the CMU indicators.

Table 7-9 Description of the CMU indicators

Indicator/Button	Color	Description
RUN/ALM	Green	If the indicator blinks every 2s (0.5 Hz), it indicates that the system is in normal state. If the indicator blinks every 0.25s (4 Hz), it indicates that the system is unregistered.

Indicator/Button	Color	Description
	Red	If the indicator is on, it indicates that the board is faulty. If the indicator blinks every 2s (0.5 Hz), it indicates that an alarm is generated because of a fault on the CMU, fans or power. If the indicator blinks every 0.25s, the output power is insufficient.
ACT	Green	Indicates the active CMU or the standby CMU. If the indicator is on, it indicates that the CMU is the active one. If the indicator is off, it indicates that the CMU is the standby one.

8 List of Boards

About This Chapter

This chapter describes the types and technical specifications of the boards.

[8.1 Boards Supported by the S7700](#)

This section describes the boards supported by the S7700.

[8.2 Power Consumption and Weight](#)

This section describes the power consumption and weight of boards.

8.1 Boards Supported by the S7700

This section describes the boards supported by the S7700.

NOTE

LPU are classified into S series boards, E series boards, F series boards:

- S series boards are SA boards, for example, 24-port 100M/1000M Ethernet optical LPU (SA, SFP)-32K MAC address entries.
- E series boards include EA, EC, and ED boards, for example, 48-port 100M Ethernet optical LPU (EA, SFP)-32K MAC address entries.
- F series boards include FA and FC boards, for example, 48-port 1000M Ethernet electrical LPU (FA, RJ45)-32K MAC address entries.

The following tables list the boards supported by the S7700.

Table 8-1 Main control boards and subcards

Name	Description
SRUA	Main control board applied to the S7712 and S7706. The unidirectional switching capacity is 256 Gbit/s.
SRUB	Main control board applied to the S7712 and S7706. The unidirectional switching capacity is 512 Gbit/s.
MCUA	Main control board applied to the S7703.
VSTSA	Stack interface flexible pluggable card on the SRU, used to provide the switch stacking function.
FSUA	Flexible service subcard on an SRU, enhancing service processing capability on the SRU.

Table 8-2 CMU

Name	Description
CMUA	Centralized monitoring unit, monitoring the operations on the S7712 and S7706. It provides two interfaces: RS485 and MON.

Table 8-3 Service boards

Name	Description
VAMPA	Value-added service (VAS) board.

Table 8-4 Ethernet LPUs

Name	Description
F48TA	48-port 10/100BASE-T interface line card (EA, RJ45)-32K MAC address entries
F48TC	48-port 10/100BASE-T interface line card (EC, RJ45)-128K MAC address entries
F48TFA	48-port 10/100BASE-T interface line card (FA, RJ45)-32K MAC address entries
G48SA	48-port 100/1000BASE-X interface line card (EA, SFP)-32K MAC address entries
G48SC	48-port 100/1000BASE-X interface line card (EC, SFP)-128K MAC address entries
G48SD	48-port 100/1000BASE-X interface line card (ED, SFP)-512K MAC address entries
G48SFA	48-port 100/1000BASE-X interface line card (FA, SFP)-32K MAC address entries
G48TA	48-port 10/100/1000BASE-T interface line card (EA, RJ45)-32K MAC address entries
G48TC	48-port 10/100/1000BASE-T interface line card (EC, RJ45)-128K MAC address entries
G48TFA	48-port 10/100/1000BASE-T interface line card (FA, RJ45)-32K MAC address entries
G48CEAT	36-port 10/100/1000BASE-T and 12-port 100/1000BASE-X interface line card (EA, RJ45/SFP)-32K MAC address entries
G48VA	48-port 10/100/1000BASE-T PoE interface line card (EA, RJ45, PoE)-32K MAC address entries
X4UXA	4-port 10GBASE-X interface line card (EA, XFP)-32K MAC address entries
X4UXC	4-port 10GBASE-X interface line card (EC, XFP)-128K MAC address entries
X2UXA	2-port 10GBASE-X interface line card (EA, XFP)-32K MAC address entries
X2UXC	2-port 10GBASE-X interface line card (EC, XFP)-128K MAC address entries
X4UXD	4-port 10GBASE-X interface line card (EC, XFP)-512K MAC address entries
G24SA	24-port 100/1000BASE-X interface line card (SA, SFP)-32K MAC address entries
G24SC	24-port 100/1000BASE-X interface line card (EC, SFP)-128K MAC address entries
G24CA	24-port 100/1000BASE-X and 8-port 10/100/1000BASE-T interface line card (SA, SFP/RJ45)

Name	Description
X12SA	12-port 10GBASE-X interface line card (SA, SFP+)
T24XA	24-port 10/100/1000BASE-T and 2-port 10GBASE-X interface line card (EA, RJ45/XFP)-32K MAC address entries
S24XA	24-port 100/1000BASE-X and 2-port 10GBASE-X interface line card (EA, SFP/XFP)-32K MAC address entries
G24TFA	24-port 10/100/1000BASE-T interface line card (FA, RJ45)-32K MAC address entries
X40SFC	40-port 10GE Ethernet optical interface line card (FC, SFP+)
X16SFC	16-port 10GE Ethernet optical interface line card (FC, SFP+)

 **NOTE**

- The Small Form-factor pluggable (SFP) is a hot pluggable optical module.
- The 10 Gigabit Small Form-Factor Pluggable (XFP) is a 10G hot pluggable optical module.
- The 10 Gigabit Small Form-Factor Pluggable (SFP+) is a 10G hot pluggable optical module. Its caliber is smaller than the caliber of the XFP optical module.
- By default, the transmission rate of an optical interface is 1000 Mbit/s and the 100M/1000M auto-negotiation is not supported. To use 100 Mbit/s optical interfaces, you must configure it manually.

8.2 Power Consumption and Weight

This section describes the power consumption and weight of boards.

Table 8-5 shows the power consumption and weight of boards on the S7700. Suppose that the temperature in the equipment room is 25°C.

Table 8-5 Power consumption and weight of boards

Board	Maximum Power Consumption	Weight
SRUA	81 W (including FSUA)	2.80 kg
MCUA	18 W	0.90 kg
SRUB	105 W (including FSUA)	2.90 kg
CMUA	1 W	0.22 kg
VAMPA	120 W	3.1 kg
FSUA	20 W	0.42 kg
VSTSA	12 W	1 kg
G48SA	75 W	2.54 kg

Board	Maximum Power Consumption	Weight
G48SC	92 W	2.66 kg
G48SD	110 W	2.66 kg
G48SFA	65 W	2.60 kg
G48TA	62 W	2.50 kg
G48TC	68 W	2.62 kg
G48TFA	48 W	2.50 kg
G48CEAT	62 W	2.50 kg
G48VA	64 W (excluding PoE power consumption)	2.6 kg
F48TA	59 W	2.50 kg
F48TC	70 W	2.62 kg
F48TFA	40 W	2.30 kg
S24XA	65 W	2.4 kg
G24CA	67 W	2.26 kg
G24SA	45 W	2.22 kg
G24SC	63 W	2.66 kg
G24TFA	32 W	2.20 kg
T24XA	53 W	2.3 kg
X12SA	85 W	2.3 kg
X4UXA	64 W	2.16 kg
X4UXC	75 W	2.28 kg
X4UXD	76 W	2.30 kg
X2UXA	52 W	2.14 kg
X2UXC	61 W	2.26 kg
X12SA	85 W	2.3 kg
X40SFC	183 W	2.90 kg
X16SFC	150 W	2.60 kg

9 Attribute List of Interfaces and Its Pluggable Modules

About This Chapter

This chapter describes the attributes of interfaces and optical modules supported by the S7700.

[9.1 Electrical Interface Attributes](#)

This section describes the attributes of electrical interfaces.

[9.2 Attributes of 10GE Optical Interfaces and 10GE Optical Modules](#)

This section describes the attributes of 10GE optical interfaces and 10GE Optical Modules.

[9.3 Attributes of GE Optical Interfaces and GE Optical Modules](#)

This section describes the attributes of GE optical interfaces and GE optical modules.

[9.4 Attributes of FE Optical Interfaces FE Optical Modules](#)

This section describes the attributes of FE optical interfaces and FE optical modules.

[9.5 Colored Optical Module Attributes](#)

This section describes the attributes of colored optical modules.

[9.6 Attributes of a 40G Optical Module](#)

This section describes the attributes of a QSFP+-40G optical module.

9.1 Electrical Interface Attributes

This section describes the attributes of electrical interfaces.

Table 9-1 lists the attributes of electrical interfaces.

Table 9-1 Attributes of the 10M/100M/1000M Base-T Ethernet interface

Attribute	Description
Connector type	RJ45
Compliance standard	IEEE 802.3ab
Frame format	Ethernet_II, Ethernet_SAP, Ethernet_SNAP
Network protocol	IP

9.2 Attributes of 10GE Optical Interfaces and 10GE Optical Modules

This section describes the attributes of 10GE optical interfaces and 10GE Optical Modules.

Each interface of the 10GE optical LPU has an optical module. **Table 9-2**, **Table 9-3** and **Table 9-4** show the attributes of the interface and the optical module.

 **NOTE**

- The SFP+ and the XFP are 10G hot-pluggable optical modules. Compared with the XFP, the SFP+ has smaller width.
- The 10G SFP+ and XFP optical modules support LAN access and WAN access functions.

Table 9-2 Interface attributes of the 10GE optical LPU

Attribute	Description
Connector type	LC/PC
Optical interface attribute	Depending on the SFP+ or XFP optical module. For details about the attributes of the optical module, see Table 9-3 and Table 9-4 .
Compliance standard	IEEE 802.3ae
Frame format	Ethernet_II, Ethernet_SAP, or Ethernet_SNAP
Network protocol	IP

Table 9-3 Attributes of the SFP+ optical module (10GE)

Attribute	Description				
Transmission distance	220 m	300 m	10 km	40 km	80 km
Center wavelength	1310 nm	850 nm	1310 nm	1550 nm	1550 nm
Transmitting power	-6.5 dBm to -0.5 dBm	-7.3 dBm to -1 dBm	-8.2 dBm to 0.5 dBm	-4.7 dBm to 4.0 dBm	0 dBm to 4 dBm
Receiver sensitivity	-6.5 dBm	-11.1 dBm	-12.6 dBm	-14.1 dBm	-24.0 dBm
Overload optical power	1.5 dBm	-1.0 dBm	0.5 dBm	-1.0 dBm	-7.0 dBm
Extinction ratio	3.5 dB	3 dB	3.5 dB	3 dB	9 dB
Fiber type	Multi-mode Modal bandwidth and fiber diameter: <ul style="list-style-type: none"> ● 500 Mkm, 62.5 um ● 500 Mkm, 62.5 um, OM1 ● 500 Mkm, 50 um, OM2 ● 500 Mkm, 50 um, OM3 	Multi-mode Modal bandwidth: 2000 Mkm Fiber diameter: 50 um	Single-mode		

Table 9-4 Attributes of the XFP optical module (10GE)

Attribute	Description			
Transmission distance	300 m	10 km	40 km	80 km

Attribute	Description			
Center wavelength	850 nm	1310 nm	1550 nm	1550 nm
Transmitting power	-7.3 dBm to -1.3 dBm	-6.0 dBm to -1.0 dBm	-1.0 dBm to 2.0 dBm	0 dBm to 4 dBm
Receiver sensitivity	-7.5 dBm	-11.0 dBm	-15.0 dBm	-24.0 dBm
Overload optical power	-1.0 dBm	0.5 dBm	-1.0 dBm	-7.0 dBm
Fiber type	Multi-mode Modal bandwidth: 2000 Mkm Fiber diameter: 50 um	Single-mode		

 **NOTE**

Only Huawei certified optical modules can be installed on the S7700. The non-certified optical modules are unreliable and may affect services. Huawei will not be responsible for fixing the issues caused by non-certified optical modules.

All the optical modules listed in the documentation are Huawei certified optical modules.

9.3 Attributes of GE Optical Interfaces and GE Optical Modules

This section describes the attributes of GE optical interfaces and GE optical modules.

Each interface of the GE optical LPU has an optical module. [Table 9-5](#), [Table 9-6](#) and [Table 9-7](#) show the attributes of the interface and the optical module.

Table 9-5 Interface attributes of the GE optical LPU (100M/1000M Base-SFP)

Attribute	Description
Connector type	LC/PC
Optical interface attribute	Depending on the SFP optical module.
Compliance standard	IEEE 802.3z
Frame format	Ethernet_II, Ethernet_SAP, or Ethernet_SNAP
Network protocol	IP

Table 9-6 Attributes of the SFP optical module (GE)

Attribute	Description							
	500 m	10 km	10 km (single-mode bidirectional fiber)		40 km	40 km	80 km	100 km
Center wavelength	850 nm	1310 nm	Tx: 1310 nm Rx: 1490 nm	Tx: 1490 nm Rx: 1310 nm	1310 nm	1550 nm	1550 nm	1550 nm
Transmitting power	-9.5 dBm to -2.5 dBm	-9.0 dBm to -3.0 dBm	-9.0 dBm to -3.0 dBm	-9.0 dBm to -3.0 dBm	-5.0 dBm to 0 dBm	-5.0 dBm to 0 dBm	-2.0 dBm to 5.0 dBm	0 dBm to 5 dBm
Receiver sensitivity	-17.0 dBm	-20.0 dBm	-19.5 dBm	-19.5 dBm	-23 dBm	-22 dBm	-23.0 dBm	-30.0 dBm
Overload optical power	0 dBm	-3.0 dBm	-3.0 dBm	-3.0 dBm	-3.0 dBm	-3.0 dBm	-3.0 dBm	-9.0 dBm
Extinction ratio	9 dB	9 dB	6 dB	6 dB	9 dB	8.5 dB	9 dB	8 dB
Fiber type	Multi-mode Modal bandwidth: 400Mkm Fiber diameter: 50 um	Single-mode						

Table 9-7 Attributes of copper modules

Attribute	Description
Connector	RJ45
Standards compliance	IEEE802.3ab
Frame format	Ethernet_II, Ethernet_SAP, or Ethernet_SNAP
Network protocol	IP

 **NOTE**

Only Huawei certified optical modules can be installed on the S7700. The non-certified optical modules are unreliable and may affect services. Huawei will not be responsible for fixing the issues caused by non-certified optical modules.

All the optical modules listed in the documentation are Huawei certified optical modules.

9.4 Attributes of FE Optical Interfaces FE Optical Modules

This section describes the attributes of FE optical interfaces and FE optical modules.

Each interface of the FE optical LPU has an optical module. [Table 9-8](#) and [Table 9-9](#) show the attributes of the interface and the optical module.

Table 9-8 Interface attributes of the FE optical LPU (100M Base-SFP)

Attribute	Description
Connector type	LC/PC
Optical interface attribute	Depending on the SFP optical module. For details about the attributes of the optical module, see Table 9-9 .
Compliance standard	IEEE 802.3u
Frame format	Ethernet_II, Ethernet_SAP, or Ethernet_SNAP
Network protocol	IP

Table 9-9 Attributes of the SFP optical module (FE)

Attribute	Description				
Transmission distance	2 km	15 km	15 km (single-mode bidirectional fiber)	40 km	80 km

Attribute	Description					
Center wavelength	1310 nm	1310 nm	Tx: 1310 nm Rx: 1550 nm	Tx: 1550 nm Rx: 1310 nm	1310 nm	1550 nm
Transmitting power	-19.0 dBm to -14.0 dBm	-15.0 dBm to -8.0 dBm	-15.0 dBm to -8.0 dBm	-15.0 dBm to -8.0 dBm	-5.0 dBm to 0 dBm	-5.0 dBm to 0 dBm
Receiver sensitivity	-30.0 dBm	-31.0 dBm	-32.0 dBm	-32.0 dBm	-37.0 dBm	-37.0 dBm
Overload optical power	-14.0 dBm	-8.0 dBm	-8.0 dBm	-8.0 dBm	-10.0 dBm	-10.0 dBm
Extinction ratio	10 dB	8.2 dB	8.5 dB	8.5 dB	10.5 dB	10.5 dB
Fiber type	Multi-mode	Single-mode				

 **NOTE**

Only Huawei certified optical modules can be installed on the S7700. The non-certified optical modules are unreliable and may affect services. Huawei will not be responsible for fixing the issues caused by non-certified optical modules.

All the optical modules listed in the documentation are Huawei certified optical modules.

9.5 Colored Optical Module Attributes

This section describes the attributes of colored optical modules.

[Table 9-10](#) and [Table 9-11](#) list attributes of CWDM optical modules.

Table 9-10 Attributes of an ESFP-CWDM optical module (100 Mbit/s or 1000 Mbit/s)

Attribute	Description
Transmission distance	80 km

Attribute	Description							
Center wavelength	1471 nm	1491 nm	1511 nm	1531 nm	1551 nm	1571 nm	1591 nm	1611 nm
Transmit optical power	0 dBm to 5.0 dBm							
Receiver sensitivity	-28.0 dBm							
Overload optical power	-9.0 dBm							
Extinction ratio	8.5 dB							

Table 9-11 Attributes of an XFP-CWDM optical module (10 Gbit/s)

Attribute	Description							
Transmission distance	70 km							
Center wavelength	1471 nm	1491 nm	1511 nm	1531 nm	1551 nm	1571 nm	1591 nm	1611 nm
Transmit optical power	0 dBm to 3.0 dBm							
Receiver sensitivity	-21.0 dBm							
Overload optical power	-9.0 dBm							
Extinction ratio	8.2 dB							

Table 9-12 and **Table 9-13** list attributes of the DWDM optical module.

Table 9-12 Attributes of an ESFP-DWDM optical module (100 Mbit/s or 1000 Mbit/s)

Attribute	Description								
Transmission distance	120 km								
Center wavelength	1529.55 nm	1533.47 nm	1537.40 nm	1541.35 nm	1545.32 nm	1549.32 nm	1553.33 nm	1557.36 nm	
	1530.33 nm	1534.25 nm	1538.19 nm	1542.14 nm	1546.12 nm	1550.12 nm	1554.13 nm	1558.17 nm	
	1531.12 nm	1535.04 nm	1538.98 nm	1542.94 nm	1546.92 nm	1550.92 nm	1554.94 nm	1558.98 nm	
	1531.90 nm	1535.82 nm	1539.77 nm	1543.73 nm	1547.72 nm	1551.72 nm	1555.75 nm	1559.79 nm	
	1532.68 nm	1536.61 nm	1540.56 nm	1544.53 nm	1548.51 nm	1552.52 nm	1556.56 nm	1560.61 nm	
Transmit optical power	0 dBm to 4.0 dBm								
Receiver sensitivity	-28.0 dBm								
Overload optical power	-8.0 dBm								
Extinction ratio	8.2 dB								
Operating temperature	0°C to 45°C								

Table 9-13 Attributes of an XFP-DWDM optical module (10 Gbit/s)

Attribute	Description
Transmission distance	80 km

Attribute	Description							
Center wavelength	1529.5 5 nm	1530.3 3 nm	1531.1 2 nm	1531.9 0 nm	1532.6 8 nm	1533.4 7 nm	1534.2 5 nm	1535.0 4 nm
	1548.5 1 nm	1549.3 2 nm	1550.1 2 nm	1550.9 2 nm	1551.7 2 nm	1552.5 2 nm	1553.3 3 nm	1554.1 3 nm
Transmit optical power	-1.0 dBm to 3.0 dBm							
Receiver sensitivity	-24.0 dBm							
Overload optical power	-9.0 dBm							
Extinction ratio	8.2 dB							

 **NOTE**

Only Huawei certified optical modules can be installed on the S7700. The non-certified optical modules are unreliable and may affect services. Huawei will not be responsible for fixing the issues caused by non-certified optical modules.

All the optical modules listed in the documentation are Huawei certified optical modules.

9.6 Attributes of a 40G Optical Module

This section describes the attributes of a QSFP+-40G optical module.

Table 9-14 lists the attributes of a QSFP+-40G optical module.

Table 9-14 Attributes of a QSFP+ 40G (41.25 Gbit/s) optical module

Attribute	Description
Transmission distance	150 m
Center wavelength	850 nm
Transmit power	-7.6 dBm to 2.4 dBm

Attribute	Description
Receiver sensitivity	-5.4 dBm
Extinction ratio	3 dB
Fiber type	OM3/OM4 multi-mode fiber
Connector type	MPO

 **NOTE**

Only Huawei certified optical modules can be installed on the S7700. The non-certified optical modules are unreliable and may affect services. Huawei will not be responsible for fixing the issues caused by non-certified optical modules.